



New South Wales

Road Transport (General) Regulation 2021

under the

Road Transport Act 2013

[*The following enacting formula will be included if this Regulation is made—*]

Her Excellency the Governor, with the advice of the Executive Council, has made the following Regulation under the *Road Transport Act 2013*.

Minister for Transport and Roads

Explanatory note

The object of this Regulation is to remake, with substantial amendments, the *Road Transport (General) Regulation 2013*, which will be repealed on 1 September 2021 by the *Subordinate Legislation Act 1989*, section 10(2).

This Regulation makes provision for the following—

- (a) offences relating to responsible use of certain vehicles in particular circumstances,
- (b) substances which are prescribed as drugs for the purposes of the Act, and further provision for the alcohol and drug use testing processes under the Act, Schedule 3,
- (c) the prescribing of signs, signals, markings, structures or other devices as prescribed traffic control devices for the purposes of the Act, Part 5.3,
- (d) the manner of testing approved traffic enforcement devices for accuracy and functional requirements,
- (e) the processes for the seizure and impounding of vehicles,
- (f) mass, dimension and load requirements for light vehicles and light combinations, and the measuring procedures for determining loads and mass,
- (g) the prescribing of heavy vehicles to which the vehicle monitoring requirements under the Act, Part 6.1 apply,
- (h) the prescribing of classes of vehicles to which the speed limiter requirements under the Act, Part 6.2 apply, and the manner of limiting the speed of those vehicles,
- (i) parking schemes, including schemes for paid parking, mobility parking, loading zones and parking in special event areas,
- (j) determination of criminal responsibility for offences under this Regulation,
- (k) offences against a provision of the road transport legislation which may be dealt with by way of penalty notice, and the amount of penalties payable for offences if dealt with in that way,

public consultation draft

Road Transport (General) Regulation 2021 [NSW]
Explanatory note

- (l) appeals processes and decisions of Transport for NSW which may or may not be the subject of an appeal to the Local Court,
- (m) service requirements for documents served on persons under the road transport legislation,
- (n) other miscellaneous matters.

Contents

	Page
Part 1 Preliminary	
1 Name of Regulation	10
2 Commencement	10
3 Interpretation	10
Part 2 Safety and traffic management	
Division 1 Responsibility for certain vehicle use	
4 Causing, permitting or allowing certain 4.5 tonne vehicles and combinations to be driven in excess of 100 kilometres per hour	11
5 Use of vehicle dropping waste oil or grease	11
6 Use of motor bike sidecars	11
7 Number of vehicles drawn together	11
8 Use of lights on vehicles generally	12
9 Use of crimson flashing warning lights on certain council vehicles	12
10 Use of lights on stationary vehicles	12
11 Carriage of dangerous goods in prohibited areas	13
12 Use of lengthy vehicles in central Sydney and on certain other roads	13
13 Prohibition on car minding	13
14 Inspection of driver licences by responsible persons	14
15 Responsible person's consent	14
16 Parents not to cause or permit children to drive on roads	14
17 School buses	14
18 Warning signs and lights for school buses	15
19 Safety provisions for buses first registered on or after 1 August 1997	15
20 Door requirements for buses registered before 1 August 1997	16
Division 2 Alcohol and other drug use	
21 Substances prescribed as drugs for the purposes of the definition of "drug" in the Act, s 4(1)	17
22 Persons prescribed as authorised sample takers	17
23 Premises, institutions and establishments prescribed for the purposes of the Act, Schedule 3	17
24 Analysis of oral fluid, blood and urine samples—laboratory prescribed	18
25 Standards for approved oral fluid analysing instruments and testing devices	18
Division 3 Prescribed traffic control devices	
26 Devices prescribed for the purposes of the Act s 121	18
27 Offence—preventing traffic control device from being clearly observed	18
28 Offence—displaying "do not overtake turning vehicle sign" on vehicles less than 7.5 metres long	19
Division 4 Approved traffic enforcement devices	
29 Testing and security indicators for approved traffic enforcement devices	19
30 Public transport lane offences	20

public consultation draft

Road Transport (General) Regulation 2021 [NSW]
Contents

	Page
Division 5 Child safety	
31 Schemes to assist children to cross roads	20
Part 3 Seizure and impounding of vehicles	
Division 1 Interpretation	
32 Definitions	22
Division 2 Seizure of vehicles by police officers	
33 When police officers may seize motor vehicles or trailers	22
34 Where seized vehicle to be kept	23
35 Commissioner of Police to notify responsible person of seizure	23
36 Applications for release of seized motor vehicle or trailer	23
37 Disposal or destruction of seized motor vehicle or trailer	24
Division 3 Seizure of vehicles by council employees in Kings Cross area	
38 When council employees may seize motor vehicles or trailers	24
39 Where seized vehicle to be kept	24
40 Enforcement officer to notify TfNSW	24
41 Enforcement officer to notify responsible person of seizure	25
42 Application for release of seized motor vehicle or trailer	25
43 Disposal or destruction of seized motor vehicle or trailer in accordance with direction of Commissioner of Police	26
Division 4 Impounded vehicles	
44 Impounding fee	26
45 Towing fee for impounded vehicles	26
46 Exceptions to towing fee	26
47 Notice of sale of impounded vehicles or vehicles forfeited to the Crown	27
48 Offer for sale of impounded vehicles or vehicles forfeited to the Crown	28
49 Application for balance of proceeds of sale	28
Part 4 Mass, dimension and load requirements for light vehicles and light combinations	
Division 1 Preliminary	
50 Application of Part	29
51 Definitions	29
52 Use of vehicle in contravention of dimension, mass or load restraint requirements	29
Division 2 Mass limits for certain motor lorries and certain trailers	
53 Definitions	29
54 Application of Division	30
55 Mass limit not to be exceeded	30
56 Mass limits for motor lorries other than existing motor lorries	30
57 Mass limits for existing motor lorries	31
58 Determination of different mass limits	31
59 TfNSW may require information or certificate	32

public consultation draft

Road Transport (General) Regulation 2021 [NSW]
Contents

	Page
Division 3 Dimension requirements	
60 Projection of loading or equipment of vehicles	32
61 Exemption by notice in Gazette	35
62 Exemption by permit	36
Division 4 Other mass and dimension requirements	
63 Special mass limits	36
64 Mass limits for three-wheeled vehicles	36
65 Lower limit to apply if multiple mass requirements	36
66 Load requirements	36
67 Driver to have sufficient control	37
Division 5 Checking and measuring procedures	
68 Method of determining wheel loads	37
69 Method of determining axle loads	37
70 Method of determining total mass	38
71 Weighing devices	38
Division 6 Miscellaneous	
72 Keeping documents	38
73 Exemptions in emergencies	38
Part 5 Road transportation	
Division 1 Monitoring of heavy vehicles and vehicles carrying dangerous goods	
74 Vehicles to which the Act, Part 6.1 applies, in addition to vehicles carrying dangerous goods	40
75 Prescribed officers for the purposes of the Act, Part 6.1	40
76 Manner of approval of aspects of data recording and related matters	40
77 Accessories to contravention of the Act, Part 6.1	40
78 Manner of granting exemptions	40
Division 2 Speed limiters	
79 Application of the Act, Part 6.2	41
80 Manner of limiting speed	41
81 Modifications	42
82 Authorised person for certification of speed limiter compliance	42
83 Exemptions	43
Part 6 Pay parking schemes	
Division 1 Operation of pay parking schemes	
84 Establishment of pay parking schemes	44
85 Pay parking fees	44
86 Requirements for pay parking space, area or device	44
87 Duration of pay parking period	44
88 Evidence of payment of parking fee	44
89 Damage to or misuse of pay parking devices	45
90 Temporary closure of pay parking space or pay parking area	45

public consultation draft

Road Transport (General) Regulation 2021 [NSW]
Contents

	Page
91 Trailers not separately chargeable	45
Division 2 Miscellaneous	
92 Councils' common pay parking schemes	45
93 TfNSW guidelines	45
94 Other powers to provide pay parking	46
95 Overlapping schemes	46
96 Application of money from parking	46
97 Disputes	47
98 Powers of police in emergency or obstruction or danger to traffic	47
Part 7 Mobility parking scheme authorities	
Division 1 Preliminary	
99 Definitions	48
Division 2 Issue of scheme authorities	
100 TfNSW may issue mobility parking scheme authorities	48
101 Form of scheme authority	48
102 When scheme authority ceases to be in force	49
Division 3 Applications for scheme authorities	
103 Procedure to obtain scheme authority	49
104 Application fees	49
105 Surrender of current or expired scheme authority if applying for new authority	50
Division 4 Collection and use of information	
106 Information about eligibility for and use of scheme authority	50
107 Evidence of disability	50
108 Change and verification of details of scheme authority holder	51
109 Information collected under Division 3 or 4	51
Division 5 Photographs	
110 TfNSW may require the taking of photographs	51
111 Purposes for which photographs may be kept and used	52
112 Release of photographs prohibited	52
Division 6 Use of scheme authorities	
113 Conditions of scheme authorities	52
114 Improper use of scheme authorities	53
115 Reproducing, copying, defacing, altering or destroying scheme authorities	53
116 Return of scheme authorities	53
117 Production and confiscation of scheme authorities	53
Division 7 Expiry and revocation of scheme authorities	
118 Expiry of scheme authorities	54
119 Revocation of scheme authorities	54

Part 8	Other parking schemes—parking permits, controlled loading zones and special event parking schemes	
	Division 1 Parking permits	
120	Parking permits	56
	Division 2 Controlled loading zone schemes	
121	Controlled loading zone schemes	56
122	Form and duration of loading zone ticket	57
123	Evidence of lawful use of controlled loading zone	57
124	Damage to and misuse of controlled loading zone device	57
125	Temporary closure of controlled loading zone	57
126	TfNSW guidelines	57
	Division 3 Special event parking schemes	
127	Special event parking schemes	58
Part 9	Compliance and enforcement	
	Division 1 Criminal responsibility	
128	Determination of criminal responsibility	59
129	Operation of Crimes (Sentencing Procedure) Act 1999 not affected	59
130	No double jeopardy for offence against this Regulation and the Road Rules 2014	59
131	Prescribed ground of exculpation in relation to average speed detection—the Act, s 129(2)	59
	Division 2 Penalty notice offences	
132	Definitions	60
133	Penalty notice offences	60
134	Penalty levels	61
135	Penalty levels for certain camera recorded offences	62
136	Lower penalty levels for certain parking offences dealt with by penalty notice	62
137	Grace period for certain parking offences	63
138	Offence—unlawful destruction of penalty notices	64
Part 10	Appeals	
	Division 1 Preliminary	
139	Definition	65
	Division 2 Appealable decisions	
140	Driver licensing decisions	65
141	Vehicle registration decisions	65
142	Mobility parking scheme decisions	66
143	Exclusion from definition of “appealable decision”	66
	Division 3 Notification of appeal rights and giving of reasons concerning driver licensing decisions	
144	Preliminary	66

public consultation draft

Road Transport (General) Regulation 2021 [NSW] Contents

	Page	
145	Notification of appeal rights in relation to certain driver licensing decisions	66
146	Application for reasons for decision	67
Division 4 Stays and adjournments		
147	Certain decisions stayed pending appeal	67
148	Certain decisions stayed only in exceptional circumstances	67
149	Adjournment of certain proceedings	68
Division 5 Determination of certain appeals		
150	Appeals against suspension of registration	69
151	Document that may be used in examiner's and proprietor's authorities appeals	69
152	Determination of driver licence suspension appeals involving death or grievous bodily harm	69
Part 11 Miscellaneous		
Division 1 Special service requirements		
153	Application of Division	70
154	Service of notices on persons and delivery of things to TfNSW under driver licensing law	70
155	Service of notices on registered operators and delivery of things to TfNSW under vehicle registration law	71
156	Date of effecting service	71
157	Forwarding, surrendering or delivering notification, document or thing to TfNSW	71
158	Service of documents under Part 7—mobility parking scheme authorities	71
Division 2 Operation of inconsistent legislation		
159	Royal Botanic Gardens and Domain Trust Act 1980	72
160	Local Government Act 1993	72
Division 3 Offences and matters relating to offences		
161	Offence—failure to comply with order, notice, direction, requirement or request	73
162	Offence—false or misleading information	73
163	Mass requirements on certain roads and bridges	73
164	Prescribed speeding offence	74
165	Limitation period for certain offences	74
166	Certain provisions not to apply to light rail vehicles	74
Division 4 Administrative matters		
167	Certificate as to costs incurred in removal of dangers and obstructions to traffic—the Act, s 142	74
168	Removal of unattended vehicles	74
169	Number-plate confiscation notices	75
170	Fees for information from records of TfNSW	75
171	Delegation of TfNSW's licensing and registration functions	75
172	Savings and repeal of Road Transport (General) Regulation 2013	76
173	Repeal of Schedule 7	76

public consultation draft

Road Transport (General) Regulation 2021 [NSW]
Contents

	Page	
Schedule 1	Fees and charges	77
Schedule 2	Declared organisations	78
Schedule 3	Substances prescribed as drugs	86
Schedule 4	Authorised officers	88
Schedule 5	Penalty notice offences	90
Schedule 6	Lower penalty levels for certain parking offences	108
Schedule 7	Amendment of other legislation	109
Schedule 8	Dictionary	118

Road Transport (General) Regulation 2021

under the

Road Transport Act 2013

Part 1 Preliminary

1 Name of Regulation

This Regulation is the *Road Transport (General) Regulation 2021*.

2 Commencement

This Regulation commences on 1 September 2021 and is required to be published on the NSW legislation website.

Note. This Regulation replaces the *Road Transport (General) Regulation 2013*, which is repealed on 1 September 2021 by the *Subordinate Legislation Act 1989*, section 10(2).

3 Interpretation

- (1) The Dictionary in Schedule 8 defines words used in this Regulation.
Note. The Act and the *Interpretation Act 1987* contain definitions and other provisions affecting the interpretation and application of this Regulation.
- (2) A reference in this Regulation to a **road** includes a reference to a **road related area**, unless otherwise expressly stated in this Regulation.
Note. The terms **road** and **road related area** are defined in the Act, section 4(1).
- (3) In this Regulation, an abbreviation or symbol specified in the *Road Rules 2014*, Schedule 1 has the same meaning as it has in the Schedule.
- (4) In Schedule 2, **public road** has the same meaning as in the *Roads Act 1993*.

Part 2 Safety and traffic management

Division 1 Responsibility for certain vehicle use

4 Causing, permitting or allowing certain 4.5 tonne vehicles and combinations to be driven in excess of 100 kilometres per hour

- (1) A person must not cause, permit or allow a vehicle with a GVM over 4.5 tonnes or a vehicle and trailer combination with a GCM over 4.5 tonnes to be driven on a road at a speed in excess of 100 kilometres per hour.

Maximum penalty—

- (a) if the vehicle is a coach or heavy motor vehicle—30 penalty units, or
(b) if the vehicle or vehicle and trailer combination is not referred to in paragraph (a)—20 penalty units.
- (2) Subclause (1) does not apply to the driver of the vehicle or vehicle and trailer combination.

Note. A driver who drives the vehicles in excess of 100 kilometres per hour will commit an offence against the *Road Rules 2014*, rule 20. See also the Rules, rules 21(2) and 25(3)(a).

- (3) In this clause—

heavy motor vehicle has the same meaning as in the *Road Rules 2014*, rule 10–2.

vehicle, trailer and **combination** have the same meanings as in the *Road Rules 2014*.

5 Use of vehicle dropping waste oil or grease

- (1) The responsible person for a motor vehicle or trailer must not cause, permit or allow or fail to take reasonable precautions to prevent a contravention of the *Road Rules 2014*, rule 291–2.

Maximum penalty—20 penalty units.

- (2) Subclause (1) does not apply to the driver of the motor vehicle or trailer.

Note. The *Road Rules 2014*, rule 291–2 provides the driver of a motor vehicle or trailer must not drive the vehicle without adequate precautions being taken to prevent waste oil or grease from the machinery, or from any other part, of the vehicle from dropping on the roadway.

6 Use of motor bike sidecars

- (1) The responsible person for a motor bike ridden with a passenger in a sidecar must not cause, permit or allow or fail to take reasonable precautions to prevent a contravention of the *Road Rules 2014*, rule 271 in relation to how persons travel in the sidecar.

Maximum penalty—20 penalty units.

- (2) Subclause (1) does not apply to the rider of a motor bike or a passenger in a sidecar.

Note. The *Road Rules 2014*, rule 271 provides for how persons are to ride motor bikes and travel in sidecars.

7 Number of vehicles drawn together

- (1) A person must not cause or permit a vehicle to be driven in contravention of the *Road Rules 2014*, rule 294–1(1).

Maximum penalty—20 penalty units.

- (2) Subclause (1) does not apply to the driver of the vehicle.

Note. The *Road Rules 2014*, rule 294–1 provides, subject to certain exceptions, a driver must not drive any of the following vehicles unless written permission is first obtained from Transport for NSW and all conditions of the permission are strictly complied with—

- (a) an articulated vehicle towing any motor vehicle, trailer or other vehicle,

- (b) any other motor vehicle towing more than one motor vehicle, trailer or other vehicle.

8 Use of lights on vehicles generally

- (1) A person must not cause or permit a light or other device fitted to a vehicle to be used in contravention of the *Road Rules 2014*, rule 218–1.
Maximum penalty—20 penalty units.

- (2) Subclause (1) does not apply to the driver of the vehicle.

Note. A driver who uses a light or other device fitted to the driver's vehicle in contravention of the *Road Rules 2014*, rule 218–1 will commit an offence against the rule.

9 Use of crimson flashing warning lights on certain council vehicles

- (1) A person must not cause or permit any crimson flashing warning light permitted to be fixed to a motor vehicle by the Standards to be used unless the vehicle is being used by an employee of a council for the purposes of enforcing excess weight limits legislation.
Maximum penalty—20 penalty units.

- (2) Subclause (1) does not apply to the driver of the vehicle.

Note. See the *Road Rules 2014*, rule 221–1(1) for the corresponding offence in relation to drivers.

- (3) In this clause—

excess weight limits legislation means the following—

- (a) the *Heavy Vehicle National Law (NSW)*,
(b) this Regulation, Part 4 and clause 163.

the Standards means—

- (a) the *Light Vehicle Standards Rules*, rule 114(4)–(9), or
(b) for a heavy vehicle—a corresponding heavy vehicle standard.

10 Use of lights on stationary vehicles

- (1) A person must not cause or permit a motor vehicle or trailer to stand on a road during a period of darkness unless the parking lights and any clearance or side marker light required to be fitted to the vehicle by the applicable vehicle standards law are lighted.
Maximum penalty—20 penalty units.

Note. See the *Road Rules 2014*, rule 220–1(1) for the corresponding offence in relation to drivers of motor vehicles.

- (2) A person must not cause or permit a motor vehicle to stand on a road during a period of darkness with its headlight lighted while the vehicle is not actually engaged in dropping off, or picking up, passengers.
Maximum penalty—20 penalty units.

- (3) Subclauses (1) and (2) do not apply to the driver of the motor vehicle or trailer.

Note. See the *Road Rules 2014*, rule 220–1(1) and (3) for the corresponding offence in relation to drivers of motor vehicles.

- (4) Subclause (1) does not apply to the standing of a vehicle on a length of road with street lighting rendering a motor vehicle or trailer clearly visible.

- (5) In this clause—

period of darkness has the same meaning as in the *Road Rules 2014*.

11 Carriage of dangerous goods in prohibited areas

- (1) A person must not cause, permit or allow the use of a dangerous goods transporter on or in a prohibited area.
Maximum penalty—20 penalty units.
- (2) Subclause (1) does not apply to the driver of the dangerous goods transporter.
Note. The *Road Rules 2014*, rule 300–2 provides the driver of a dangerous goods transporter must not use the vehicle on or in certain prohibited areas.
- (3) The Commissioner of Police may issue a permit, whether with or without conditions, authorising a dangerous goods transporter to be used in a prohibited area.
- (4) A person does not commit an offence against subclause (1) if the dangerous goods transporter is—
 - (a) displaying a permit issued under subclause (3) authorising it to be used in the prohibited area concerned, and
 - (b) used in accordance with the conditions on which the permit was issued.
- (5) The holder of a permit issued under subclause (3) who, without lawful excuse, contravenes a condition of the permit is guilty of an offence.
Maximum penalty—20 penalty units.
- (6) Terms or expressions used in this clause defined for the purposes of the *Road Rules 2014*, rule 300–2 have the same meanings as in the rule.

12 Use of lengthy vehicles in central Sydney and on certain other roads

- (1) A person must not cause or permit a lengthy vehicle to be driven in contravention of the *Road Rules 2014*, rule 300–3.
Maximum penalty—20 penalty units.
- (2) Subclause (1) does not apply to the driver of the lengthy vehicle.
Note. The *Road Rules 2014*, rule 300–3 provides the driver of a lengthy vehicle must not, unless written permission is first obtained from Transport for NSW and all the conditions of the permission are strictly complied with, drive the vehicle during certain times on weekdays in specified parts of central Sydney and other roads.
- (3) In this clause—
lengthy vehicle has the same meaning as in the *Road Rules 2014*, rule 300–3.

13 Prohibition on car minding

- (1) The Commissioner of Police may, by written notice served on a person, prohibit the person from—
 - (a) parking, minding, caring for, or taking charge of a motor vehicle or trailer on a road, other than a motor vehicle or trailer of which the person is the driver, or
 - (b) offering the person’s services for a purpose referred to in paragraph (a).
- (2) A person on whom a notice has been served must comply with the notice.
Maximum penalty—20 penalty units.
- (3) This clause does not authorise the Commissioner of Police to prohibit the proprietor of a parking station or parking area from—
 - (a) parking, minding, caring for, or taking charge of a motor vehicle or trailer in or on a parking station or parking area, or
 - (b) offering the proprietor’s services for a purpose referred to in paragraph (a).
- (4) Subclause (3) extends to the following—

- (a) the display or publication of an advertisement for the parking station or parking area, or
- (b) the offer or performance of the services by the proprietor or by an employee of the proprietor.

14 Inspection of driver licences by responsible persons

- (1) The responsible person for, or the person in charge of, a motor vehicle must inspect the driver licence of a person before permitting the person to drive the vehicle.

Maximum penalty—20 penalty units.

Note. The *Road Rules 2014*, rule 300–5 makes it an offence for the driver of a motor vehicle not to carry the person’s driver licence.

- (2) In this clause—

driver licence includes an Australian driver licence or a foreign driver licence.

15 Responsible person’s consent

A person in charge of a motor vehicle or trailer on a road must not permit another person to drive or use the vehicle without the consent of the responsible person for the vehicle.

Maximum penalty—20 penalty units.

16 Parents not to cause or permit children to drive on roads

- (1) A parent of a child must not cause or permit the child to drive a motor vehicle on a road.

Maximum penalty—20 penalty units.

- (2) Subclause (1) does not apply to a parent of a child if Transport for NSW—

- (a) has granted a driver licence to the child under the Act, or
- (b) has issued a learner licence to the child under the Act.

- (3) In this clause—

child means a person who is less than 16 years and 9 months of age.

parent of a child includes a person having parental responsibility within the meaning of the *Children and Young Persons (Care and Protection) Act 1998* for the child.

17 School buses

- (1) The owner of a bus must, before permitting a person to drive the bus for school purposes—

- (a) attach to the bus 2 signs complying with subclause (2), or
- (b) provide for use by the driver—
 - (i) 2 signs complying with subclause (2), and
 - (ii) the means of attaching the signs to the bus.

Maximum penalty—20 penalty units.

- (2) A sign must contain the words “School Bus” in block letters—

- (a) not less than—
 - (i) if the sign is to be displayed at the front of the bus—100 millimetres high, and
 - (ii) if the sign is to be displayed at the rear of the bus—120 millimetres high, and
- (b) in black lettering on a fluorescent yellow background.

- (3) This clause does not apply to a vehicle operated in accordance with clause 18.
- (4) In this clause—
 - drive a bus for school purposes*** means the driving of a bus that—
 - (a) is being used solely or principally for the conveyance of children to or from school, and
 - (b) is being used on a journey wholly outside a transport district.
 - transport district*** has the same meaning as in the *Transport Administration Act 1988*.

18 Warning signs and lights for school buses

- (1) The owner of a bus must not permit a person to drive the bus for school purposes on a road unless a warning system is attached to the bus.
Maximum penalty—20 penalty units.
- (2) This clause does not apply to a bus—
 - (a) operating on charter for a school excursion or being used for community service activities, and
 - (b) where no individual fares are being directly collected or school passes used.
- (3) This clause does not apply to the owner of a bus whom Transport for NSW exempts from compliance with this clause.
- (4) Transport for NSW is to make a technical specification it has approved for the purposes of this clause available on request.
- (5) In this clause—
 - drive a bus for school purposes*** means the driving of a bus—
 - (a) to convey children, whether with or without adult passengers, to or from school—
 - (i) between 7am and 9.30am on a weekday, or
 - (ii) between 2.30pm and 5pm on a weekday, or
 - (b) solely for the purpose of conveying children to or from school.
 - warning system*** means a system of signs and flashing lights that—
 - (a) is designed to warn motorists of the presence of children on a bus, and
 - (b) complies with the requirements of the technical specification approved by Transport for NSW from time to time for the purposes of this clause.

19 Safety provisions for buses first registered on or after 1 August 1997

- (1) This clause applies to a bus that—
 - (a) was first registered in this State on or after 1 August 1997, and
 - (b) is used, or has been used on or after 1 August 1997, by an accredited service operator to operate a regular passenger service within the meaning of the *Passenger Transport Act 1990*.
- (2) The owner of a bus must not permit a person to drive the bus on a road unless the bus is fitted with—
 - (a) a bus door safety system, and
 - (b) safety padding, and
 - (c) a field of view system.Maximum penalty—20 penalty units.
- (3) A person must not drive a bus on a road unless the bus is fitted with—

- (a) a bus door safety system, and
 - (b) safety padding, and
 - (c) a field of view system.
- Maximum penalty—20 penalty units.
- (4) A requirement of subclause (2) or (3) does not apply—
- (a) to the owner of a bus whom Transport for NSW exempts in writing from compliance with the requirement, and
 - (b) to the driver of a bus, the owner of which has been exempted under paragraph (a).
- (5) Transport for NSW—
- (a) may, from time to time, approve technical specifications for the purposes of this clause, and
 - (b) may apply different technical specifications to different buses in accordance with the first date of registration of the bus, and
 - (c) must make a technical specification available on request.
- (6) In this clause—
- bus door safety system** means a bus door system installed on a bus that—
- (a) is designed to prevent, without driver intervention, entrapment of persons by the closing of the doors, and
 - (b) complies with the requirements of a technical specification approved by Transport for NSW for the purposes of this clause.
- field of view system** means a system installed on a bus that—
- (a) provides the driver of the bus with an adequate view of the doorways of the bus, and
 - (b) complies with the requirements of the applicable technical specifications approved by Transport for NSW for the purposes of this clause.
- safety padding** means padding that—
- (a) is affixed to handrails, the top and back of seats, and partitions on buses, including raised items part of, or are affixed to, seats and partitions, and
 - (b) complies with the requirements of the applicable technical specifications approved by Transport for NSW for the purposes of this clause.

20 Door requirements for buses registered before 1 August 1997

- (1) This clause applies to a bus that—
- (a) was first registered in this State before 1 August 1997, and
 - (b) is fitted with driver controlled doors.
- (2) The owner of a bus must not permit a person to drive the bus on a road unless the steady force applied to an object located up to 1,500 millimetres above the door step when the door of the bus is closing does not exceed 150 newtons when measured between 20 millimetres and 300 millimetres from the door's fully closed position.
- Maximum penalty—20 penalty units.
- (3) A person must not drive a bus on a road unless the steady force applied to an object located up to 1,500 millimetres above the door step when the door of the bus is closing does not exceed 150 newtons when measured between 20 millimetres and 300 millimetres from the door's fully closed position.
- Maximum penalty—20 penalty units.

- (4) Despite subclauses (2) and (3), the steady force applied to an object located up to 1,500 millimetres above the door step when the door of the bus is closing may, if a steady force of 150 newtons results in the door not working properly, be increased to a steady force enabling the door to work properly.
- (5) However, the exemption in subclause (4) does not apply if the steady force is increased to more than 400 newtons.

Division 2 Alcohol and other drug use

21 Substances prescribed as drugs for the purposes of the definition of “drug” in the Act, s 4(1)

For the purposes of the Act, section 4(1), definition of *drug*, paragraph (c), the following are prescribed as drugs—

- (a) substances listed in Schedule 3,
- (b) substances that are salts, isomers, esters or ethers of a substance listed in Schedule 3,
- (c) substances that are salts of the isomers, esters or ethers referred to in paragraph (b).

22 Persons prescribed as authorised sample takers

- (1) For the purposes of the Act, Schedule 3, clause 1(1), definition of *authorised sample taker*, paragraph (c), the following persons or classes or descriptions of persons are prescribed as being authorised to take samples for the purposes of the Schedule—

- (a) an enrolled nurse,
- (b) a person—
 - (i) who is employed to work at a hospital, and
 - (ii) whose duties at the hospital include taking blood samples or other specimens for laboratory testing.

- (2) In this clause—

hospital includes premises, an institution or establishment prescribed as a hospital under clause 23.

23 Premises, institutions and establishments prescribed for the purposes of the Act, Schedule 3

- (1) This clause prescribes the premises, institutions or establishments that are—

- (a) a place where samples may be taken under the Act, Schedule 3 as referred to in the Act, Schedule 3, clause 1(1), definition of *prescribed place*, and
- (b) a *hospital* for the purposes of the Act, Schedule 3, clause 10(2) and the Act, Schedule 3, Part 2, Division 4.

- (2) The following premises, institutions or establishments are prescribed—

- (a) the following locations of the Royal Australian Air Force—
 - (i) Medical Section, No. 1 Central Ammunition Depot, Kingswood,
 - (ii) No. 3 RAAF Hospital, RAAF Base, Richmond,
 - (iii) Base Medical Flight, RAAF Base, Williamtown,
- (b) the 7th Camp Hospital, Kapooka, of the Australian Army,
- (c) the following locations of the Royal Australian Navy—
 - (i) Naval Hospital, HMAS Penguin, Balmoral,
 - (ii) Sick Bay, HMAS Harman, Canberra, ACT,

- (iii) Sick Bay, HMAS Kuttabul, Garden Island,
- (iv) Sick Bay, HMAS Creswell, Jervis Bay, ACT
- (v) Naval Hospital, HMAS Albatross, Nowra,
- (vi) Sick Bay, HMAS Watson, Watson's Bay,
- (vii) Sick Bay, HMAS Waterhen, Waverton.

24 Analysis of oral fluid, blood and urine samples—laboratory prescribed

The laboratory of the NSW Forensic & Analytical Science Service at Lidcombe is prescribed—

- (a) for the purposes of the Act, Schedule 3, clause 22(3), definition of *authorised laboratory*, and
- (b) for the purposes of the Act, Schedule 3, clause 23, definition of *prescribed laboratory*.

25 Standards for approved oral fluid analysing instruments and testing devices

- (1) For the purposes of the Act, Schedule 3, clause 1(1), definition of *approved oral fluid analysing instrument*, paragraph (b), the following standard is prescribed—

The instrument, when calibrated and operated properly, must be capable of confirming the presence of a prescribed illicit drug in a sample of oral fluid.

- (2) For the purposes of the Act, Schedule 3, clause 1(1), definition of *approved oral fluid testing device*, paragraph (b), the following standard is prescribed—

The device, when calibrated and operated properly, must be capable of indicating the presence of a prescribed illicit drug in oral fluid being tested where the concentration of the drug in the fluid is 150 nanograms per millilitre or greater.

Division 3 Prescribed traffic control devices

26 Devices prescribed for the purposes of the Act s 121

- (1) For the purposes of the Act, section 121, definition of *prescribed traffic control device*, the following traffic control devices are prescribed—

- (a) a traffic control device of a kind mentioned in the *Road Rules 2014* having effect for the Rules under the Rules, rule 315,

Note. See also the *Road Rules 2014*, rules 316–318.

- (b) a word, figure, symbol or anything else used on or with a traffic control device referred to in paragraph (a).

- (2) In this clause—

traffic control device has the same meaning as it has in the *Road Rules 2014*.

Note. The *Road Rules 2014* define traffic control devices to mean traffic signs, road markings, traffic signals, or other devices, to direct or warn traffic on, entering or leaving a road.

27 Offence—preventing traffic control device from being clearly observed

- (1) A person must not place or cause to be placed anything in a position that would prevent or be likely to prevent a prescribed traffic control device from being clearly observed by the driver of a motor vehicle approaching the device along a portion of a road for which the device has been installed or displayed.

Maximum penalty—20 penalty units.

Note. The Act, section 123 also makes it an offence for a person to install or display, or to interfere with, alter or remove, a prescribed traffic control device without appropriate authority.

- (2) Subclause (1) does not apply if the person has the approval of Transport for NSW to place the matter or thing along the portion of the road.
- (3) If Transport for NSW or a police officer directs a person who has contravened subclause (1) to remove immediately the matter or thing concerned, the person must comply with the direction.
Maximum penalty—20 penalty units.
- (4) In this clause—
prescribed traffic control device has the same meaning as in the Act, section 121.

28 Offence—displaying “do not overtake turning vehicle sign” on vehicles less than 7.5 metres long

- (1) A person must not cause or permit a motor vehicle to be driven on a road that has exhibited on the rear of the vehicle, or on the rear of a trailer attached to the vehicle, a *do not overtake turning vehicle sign* unless the vehicle is, or the vehicle and trailer together are, 7.5 metres long or longer.
Maximum penalty—20 penalty units.
- (2) Subclause (1) does not apply to the driver of the motor vehicle.
Note. The *Road Rules 2014*, rule 316–2 provides a driver must not drive a motor vehicle if a *do not overtake turning vehicle sign* is displayed on the rear of the vehicle or on the rear of a trailer attached to the vehicle unless the vehicle is, or the vehicle and trailer together are, 7.5 metres long or longer.
- (3) In this clause—
do not overtake turning vehicle sign means a *do not overtake turning vehicle sign* of a kind referred to in the *Road Rules 2014*.

Division 4 Approved traffic enforcement devices

29 Testing and security indicators for approved traffic enforcement devices

- (1) For the purposes of the Act, section 137(b)—
 - (a) an approved traffic enforcement device that is approved for speed measurement and is a radar based device of a kind to which the Australian Standard entitled AS 2898.1—2003, *Radar speed detection—Functional requirements and definitions* applies must be tested for accuracy and functional requirements—
 - (i) in accordance with the Standard, or
 - (ii) in accordance with the manufacturer’s recommended calibration method, and
 - (b) an approved traffic enforcement device that is approved for speed measurement and is a laser based device of a kind to which the Australian Standard entitled AS 4691.1—2003, *Laser-based speed detection devices—Definitions and device requirements* applies must be tested for accuracy and functional requirements—
 - (i) in accordance with the Standard, or
 - (ii) in accordance with the manufacturer’s recommended calibration method, and
 - (c) an approved traffic enforcement device that is approved for speed measurement and is not of a kind referred to in paragraph (a) or (b) must be tested for accuracy and functional requirements in accordance with the manufacturer’s recommended calibration method—
 - (i) as approved by the Commissioner of Police, or

- (ii) for a device used in conjunction with, or forms part of, a digital camera device—as approved by Transport for NSW, and
 - (d) the prescribed period is 12 months.
- (2) For the purposes of the Act, section 137A(b)—
 - (a) an approved traffic enforcement device approved for dimension measurement must be tested for accuracy and functional requirements in accordance with a calibration method approved by Transport for NSW, and
 - (b) the prescribed period is 12 months.
- (3) Each of the following is prescribed as a security indicator for the purposes of the Act, section 138(1)—
 - (a) a series of 32 characters produced by an MD5 algorithm,
 - (b) a series of 48 characters of which 32 characters have been produced by an MD5 algorithm,
 - (c) a series of 40 characters produced by a SHA-1 algorithm,
 - (d) a series of 56 characters produced by a SHA-224 algorithm,
 - (e) a series of 64 characters produced by a SHA-256 algorithm,
 - (f) a series of 96 characters produced by a SHA-384 algorithm,
 - (g) a series of 128 characters produced by a SHA-512 algorithm.
- (4) The prescribed period for the purposes of the Act, section 138(2)(b) is 90 days.
- (5) For the purposes of this clause, *character* includes a letter, number or symbol.

30 Public transport lane offences

For the purposes of the Act, section 135(1), definition of *public transport lane offence*, paragraph (b), the following offences are prescribed—

- (a) the *Road Rules 2014*, rule 154(1),
- (b) the *Road Rules 2014*, rule 157–1.

Division 5 Child safety

31 Schemes to assist children to cross roads

- (1) Transport for NSW may—
 - (a) from time to time give authorities for schemes (*authorised children's crossing schemes*) designed to assist children to safely cross roads, and
 - (b) for the purposes of the authority, authorise a person or class of persons to exercise and discharge the functions specified in the authority.
- (2) An authorised children's crossing scheme—
 - (a) comes into force on the date specified in the authority for the scheme, and
 - (b) may, from time to time, be amended or replaced by another scheme authorised by Transport for NSW, and
 - (c) may be revoked by Transport for NSW at any time.
- (3) A person taking part in the carrying out of a authorised children's crossing scheme must—
 - (a) be at least 18 years of age, and
 - (b) wear a safety vest issued to the person by Transport for NSW.

public consultation draft

Road Transport (General) Regulation 2021 [NSW]
Part 2 Safety and traffic management

- (4) For the purpose of carrying out an authorised children’s crossing scheme, when children are about to use or are on a crossing, a person authorised for the purpose by Transport for NSW—
- (a) may cause to be exhibited at or near the crossing, on each side of the roadway, a hand-held stop sign, or
 - (b) cause a barrier to be placed on each side of the crossing across or partly across the roadway.
- (5) A barrier referred to in subclause (4)(b)—
- (a) must be placed so it is—
 - (i) parallel to the crossing, and
 - (ii) on the side of the crossing nearer to approaching traffic, and
 - (b) must—
 - (i) be of a type approved by Transport for NSW, and
 - (ii) have affixed to it a stop sign in, or to the effect of, a hand-held stop sign, and
 - (c) must be constructed so when it is placed in position on the roadway, the stop sign affixed to it will face and be clearly visible to the driver of a motor vehicle approaching the crossing on the side of the roadway where the barrier is situated.
- (6) In court proceedings, evidence a hand-held stop sign was exhibited in accordance with this clause by a person at or near a crossing when children were about to use, or were on, the crossing, is admissible and is prima facie evidence the exhibition of the sign by the person was authorised.
- (7) In this clause—
- crossing** means—
- (a) a children’s crossing within the meaning of the *Road Rules 2014*, rule 80, or
 - (b) a pedestrian crossing within the meaning of the *Road Rules 2014*, rule 81.
- hand-held stop sign** means a traffic sign of the kind referred to in the *Road Rules 2014*, rule 80.

Part 3 Seizure and impounding of vehicles

Division 1 Interpretation

32 Definitions

In this Part—

designated road means the following roads, or parts of roads, in Kings Cross in the City of Sydney—

- (a) Amos Lane,
- (b) Barncleuth Square,
- (c) Bayswater Road, between Ward Avenue and Roslyn Street,
- (d) Brougham Street,
- (e) Earl Place,
- (f) Hughes Street,
- (g) Kings Cross Road,
- (h) Manning Street,
- (i) McDonald Street,
- (j) Orwell Street,
- (k) Rockwall Crescent,
- (l) Tusculum Street,
- (m) Victoria Street.

enforcement officer means—

- (a) the general manager, or
- (b) an employee of the City of Sydney Council authorised by the general manager to be an enforcement officer for the purposes of Division 3.

general manager means the general manager of the City of Sydney Council.

officer-in-charge means the officer-in-charge of the place at which the vehicle is kept or impounded under Division 2.

Division 2 Seizure of vehicles by police officers

33 When police officers may seize motor vehicles or trailers

- (1) A police officer may seize and take charge of, and remove or tow away or cause to be removed or towed away, a motor vehicle or trailer—
 - (a) that is a danger or unreasonable obstruction to traffic, or
 - (b) that has been abandoned on a road, or
 - (c) that has been caused or permitted to be used contrary to law on a part of a road in which is conspicuously displayed a sign exhibiting or including—
 - (i) the words “tow away area”, or
 - (ii) the words “vehicles impounded”, or
 - (iii) words indicating the vehicle is subject to seizure.
- (2) Before seizing a motor vehicle or trailer, the police officer must—
 - (a) if a person is in charge of the vehicle—
 - (i) request the person to remove the vehicle, or cause it to be removed immediately, and

- (ii) give the person a reasonable opportunity to comply with the request, or
- (b) if no person is in charge of the vehicle—
 - (i) make reasonable inquiry for the purpose of locating the responsible person for, or driver of, the vehicle, and
 - (ii) if the responsible person or driver is located—carry out the matters referred to in paragraph (a)(i) and (ii).
- (3) For the purposes of subclause (2)(b)(i), reasonable inquiry—
 - (a) must be made in the area where the vehicle is found, and
 - (b) does not authorise or require a police officer to enter a building for the purpose of the inquiry.

34 Where seized vehicle to be kept

A motor vehicle or trailer removed or towed away under clause 33 may be kept or impounded at a place appointed or set apart by the Commissioner of Police for the purpose.

35 Commissioner of Police to notify responsible person of seizure

On seizure of a motor vehicle or trailer under this Division, the Commissioner of Police must—

- (a) if the name and address of the responsible person for the vehicle are recorded in the NSW registrable vehicles register—send or cause to be sent to the person, within 14 days after the seizure, a notice setting out the following particulars—
 - (i) the time, date and place of the seizure,
 - (ii) the place where the vehicle is kept or impounded, or
- (b) if the name and address of the responsible person for the vehicle are not recorded in the NSW registrable vehicles register—
 - (i) if the responsible person for the vehicle can, after reasonable inquiry, be located—send or cause to be sent to the responsible person a notice setting out the particulars referred to in paragraph (a) within a period of 14 days after the seizure, or
 - (ii) if the responsible person for the vehicle cannot, after reasonable inquiry, be located—cause a notice setting out the particulars specified in paragraph (a) to be published in a newspaper circulating in the area in which the vehicle was seized.

36 Applications for release of seized motor vehicle or trailer

- (1) An application for the release of a motor vehicle or trailer kept or impounded under this Division must be made to an officer-in-charge by—
 - (a) the responsible person for the motor vehicle or trailer, or
 - (b) a person acting on behalf of the responsible person.
- (2) The motor vehicle or trailer must not be released from custody unless—
 - (a) the applicant has provided evidence to the officer-in-charge regarding the identity of the responsible person for the motor vehicle or trailer, and
 - (b) the officer-in-charge is satisfied the applicant—
 - (i) is the responsible person, or
 - (ii) possesses authority to act on behalf of the responsible person, and

- (c) the appropriate amount fixed by the Commissioner of Police as the amount payable for the seizure, taking charge of, removal, towing away, keeping, impounding or releasing of the motor vehicle or trailer has been paid to the officer-in-charge, and
- (d) the applicant has signed a receipt for the delivery of the motor vehicle or trailer on a form supplied to the applicant by the officer-in-charge.

37 Disposal or destruction of seized motor vehicle or trailer

A motor vehicle or trailer seized under this Division may be disposed of or destroyed in accordance with the directions of the Commissioner of Police if, within 3 months after the date on which the motor vehicle or trailer was seized, the responsible person has failed to—

- (a) claim the motor vehicle or trailer, or
- (b) pay the amount referred to in clause 36(2)(c).

Division 3 Seizure of vehicles by council employees in Kings Cross area

38 When council employees may seize motor vehicles or trailers

- (1) An enforcement officer may seize and take charge of, and remove or tow away or cause to be removed or towed away, a motor vehicle or trailer that has been caused or permitted to be used contrary to law on a part of a designated road in which is conspicuously displayed a sign exhibiting or including—
 - (a) the words “tow away area”, or
 - (b) the words “vehicles impounded”, or
 - (c) words indicating the vehicle is subject to seizure.
- (2) Before seizing a motor vehicle or trailer, the enforcement officer must—
 - (a) if a person is in charge of the vehicle—
 - (i) request the person to remove the vehicle, or cause it to be removed immediately, and
 - (ii) give the person a reasonable opportunity to comply with the request, or
 - (b) if no person is in charge of the vehicle—
 - (i) make reasonable inquiry for the purpose of locating the responsible person for, or driver of, the vehicle, and
 - (ii) if the responsible person or driver is located—carry out the matters referred to in paragraph (a)(i) and (ii).
- (3) For the purposes of subclause (2)(b)(i), reasonable inquiry—
 - (a) must be made in the area where the vehicle is found, and
 - (b) does not authorise or require an enforcement officer to enter a building for the purpose of the inquiry.

39 Where seized vehicle to be kept

A motor vehicle or trailer removed or towed away under clause 38 may be kept or impounded at a place appointed or set apart by the Commissioner of Police for the purpose.

40 Enforcement officer to notify TfNSW

- (1) As soon as practicable after the seizure of a motor vehicle or trailer, the enforcement officer must—

- (a) give Transport for NSW notice of the seizure containing a description of the vehicle to which it relates, including—
 - (i) particulars on the registration label and number-plate attached to the vehicle, if any, and
 - (ii) the identification number stamped on or applied to the engine, if any, and
 - (b) request Transport for NSW to supply the enforcement officer with the names and addresses of the responsible person for the vehicle known or available to Transport for NSW.
- (2) Transport for NSW is to give the enforcement officer the requested particulars within 3 business days after receipt of the notice.

41 Enforcement officer to notify responsible person of seizure

- (1) If the name and address of the responsible person for the vehicle are supplied by Transport for NSW, the enforcement officer must, within a period of 14 days after the seizure, send or cause to be sent to the responsible person a notice setting out the following particulars—
- (a) the time, date and place of the seizure,
 - (b) the place where the vehicle is kept or impounded.
- (2) If the name and address of the responsible person for the vehicle are not supplied by Transport for NSW, the enforcement officer must—
- (a) if the responsible person for the vehicle can, after reasonable inquiry, be located—send or cause to be sent to the responsible person a notice setting out the particulars set out in clause 40(1)(a) within a period of 14 days after the seizure, and
 - (b) if the responsible person for the vehicle cannot, after reasonable inquiry, be located—cause a notice setting out the particulars referred to in clause 40(1)(a) to be published in a newspaper circulating in the City of Sydney.

42 Application for release of seized motor vehicle or trailer

- (1) An application for the release of a motor vehicle or trailer kept or impounded under this Division must be made to the general manager at an office of the Council of the City of Sydney during office hours on a business day by—
- (a) the responsible person for the motor vehicle or trailer, or
 - (b) a person acting on behalf of the responsible person.
- (2) The application must be dealt with by an enforcement officer.
- (3) The motor vehicle or trailer must not be released from custody unless—
- (a) the applicant has provided evidence to the enforcement officer regarding the identity of the responsible person for the motor vehicle or trailer, and
 - (b) the enforcement officer is satisfied the applicant—
 - (i) is the responsible person, or
 - (ii) possesses authority to act on behalf of the responsible person, and
 - (c) the amount payable under a penalty notice served on the responsible person for an offence against this Regulation in relation to stopping or parking the motor vehicle or trailer in the portion of the designated road from which it was removed or towed away has been paid, and
 - (d) the appropriate amount fixed by Transport for NSW as the amount payable for the seizure, taking charge of, removal, towing away, keeping, impounding or

releasing of the motor vehicle or trailer has been paid to the enforcement officer, and

- (e) the applicant has signed a receipt for the delivery of the motor vehicle or trailer on a form supplied to the applicant by the enforcement officer.
- (4) For the purposes of subclause (3)(c), an amount is not to be taken to be payable under a penalty notice unless the requirements of Part 3 of the *Fines Act 1996* have been complied with.

43 Disposal or destruction of seized motor vehicle or trailer in accordance with direction of Commissioner of Police

A motor vehicle or trailer seized under this Division may be disposed of or destroyed in accordance with the directions of the general manager if, within 3 months after the date on which the motor vehicle or trailer was seized, the responsible person has failed to—

- (a) claim the motor vehicle or trailer, or
- (b) pay the amount referred to in clause 42(3)(d).

Division 4 Impounded vehicles

44 Impounding fee

For the purposes of the Act, section 250(1), the prescribed fee for storage of an impounded vehicle is the fee prescribed by Schedule 1.

45 Towing fee for impounded vehicles

- (1) A fee is payable to the Commissioner of Police by the responsible person for a vehicle towed under the Act, section 239 or 242, except as otherwise provided by this clause or clause 46.
- (2) The fee payable is the lesser of the following—
 - (a) the actual cost of towing the vehicle,
 - (b) the maximum charge for the time being determined under the *Tow Truck Industry Act 1998*, section 54, including any surcharge chargeable, in the circumstances of the case, in accordance with a determination under the section, for a vehicle towed—
 - (i) from within the Sydney metropolitan area—a 50-kilometre tow, or
 - (ii) from outside the Sydney metropolitan area—a 100-kilometre tow.
- (3) The Commissioner of Police must give notice of the fee to the responsible person for the vehicle.
- (4) Except as otherwise provided by this Regulation, the fee is due 14 days after the notice is given.

46 Exceptions to towing fee

- (1) A towing fee is only payable if—
 - (a) a person is convicted of a sanctionable offence within the meaning of the Act, Part 7.6, or
 - (b) a penalty notice, issued under the Act, Part 7.3, Division 3 in relation to the alleged offence, is dealt with by payment of—
 - (i) the penalty prescribed under the Division, or

- (ii) a penalty notice enforcement order under the *Fines Act 1996* made, or is taken to have been made, against the person and not subsequently quashed or set aside.
- (2) A towing fee is refundable if it has been paid for the towing of a vehicle in circumstances other than subclause (1).
- (3) A fee is not payable under this clause by the responsible person for the vehicle if the person provides the Commissioner of Police with a statutory declaration stating—
 - (a) the offence concerned was not committed with the responsible person's consent, and
 - (b) the responsible person did not know, and could not reasonably be expected to have known, the vehicle would be used for the commission of the offence, and
 - (c) that—
 - (i) at the time of the offence, the vehicle was being driven by a person whose name and address are supplied in the declaration, or
 - (ii) the responsible person does not know, and could not with reasonable diligence have ascertained, the name and address of the person who was driving the vehicle at the time.
- (4) A fee that, in accordance with subclause (3), is not payable by the responsible person for the vehicle is payable by the person driving the vehicle at the time of the offence concerned.
- (5) A statutory declaration of a responsible person alleging another person was the driver of the vehicle at the time of the offence is, if produced in proceedings for recovery of a fee under clause 45, evidence of the driver's identity unless evidence to the contrary is adduced.
- (6) If a court finds an offence proven in relevant proceedings it may, to avoid undue hardship to a person or a perceived injustice, order—
 - (a) the fee payable for the towing of the vehicle in connection with the alleged offence be reduced by an amount specified by the court, or
 - (b) in the circumstances of the case, no fee is payable.
- (7) In subclause (6)—
relevant proceedings means—
 - (a) proceedings for an alleged sanctionable offence within the meaning of the Act, Part 7.6, or
 - (b) an application under the Act, section 249 following the impounding of a vehicle for an alleged offence.

47 Notice of sale of impounded vehicles or vehicles forfeited to the Crown

- (1) This clause applies to a vehicle that—
 - (a) was impounded under the Act, section 239, 242 or 245, and
 - (b) has not been released, in accordance with the Act, Part 7.6, at the end of the period for which it was liable to be impounded.
- (2) The Commissioner of Police may issue a notice confirming the vehicle is liable to be offered for sale unless appropriate steps are taken to procure the release of the vehicle.
- (3) The notice must be given to—
 - (a) the registered operator of the vehicle, and

- (b) a person with a registered interest in the motor vehicle, as defined in the Act, section 237.

48 Offer for sale of impounded vehicles or vehicles forfeited to the Crown

- (1) For the purposes of the Act, section 252, a vehicle may be offered for sale if the vehicle—
 - (a) has remained impounded for 28 days after the service of notices referred to in clause 47(4), or
 - (b) has been forfeited to the Crown under the Act, section 243 or 245.
- (2) Despite subclause (1), a vehicle may not be offered for sale—
 - (a) while an application under the Act, section 249, or subsequent proceedings arising out of the application, are pending, or
 - (b) contrary to the order of a court.

49 Application for balance of proceeds of sale

- (1) A person may apply to the Commissioner of Police to receive the balance of the proceeds of sale of a vehicle sold in accordance with this Regulation within 12 months after the sale of the vehicle.
- (2) The Commissioner of Police may pay the balance of the proceeds of sale to the person if the Commissioner is satisfied that—
 - (a) the person was lawfully entitled to the vehicle immediately before its sale, and
 - (b) there was a reasonable excuse for the person's failure to obtain the release of the vehicle before it was sold.
- (3) The Commissioner of Police may require the person to provide evidence necessary to satisfy the Commissioner of the matters referred to in subclause (2).
- (4) In this clause—

balance of the proceeds of sale, for a vehicle, means the proceeds of sale of the vehicle after deduction of—

 - (a) the applicable movement, towing and storage fees payable under the Act, and
 - (b) the reasonable costs of, or incidental to, the sale of the vehicle.

Part 4 Mass, dimension and load requirements for light vehicles and light combinations

Division 1 Preliminary

50 Application of Part

- (1) This Part applies to a light vehicle or light combination on a road only.
- (2) This Part does not apply to a light vehicle or light combination used only on a railway or tramway.

51 Definitions

In this Part—

added load means the moveable load carried by a vehicle.

axle load means the total load, determined in accordance with clause 69, transmitted to the road by all wheels of a vehicle that are mounted on an axle.

load-carrying, in relation to a vehicle or combination, means a vehicle or combination carrying, or built to carry, a load.

loaded mass means the mass of a vehicle and its added load.

total mass means—

- (a) for a load-carrying vehicle or combination—the loaded mass of the vehicle or combination, and
- (b) for a non load-carrying vehicle or combination—the mass of the vehicle or combination together with—
 - (i) the goods, passengers and drivers in or on the vehicle or combination, and
 - (ii) the fuel, water, lubricants and readily removable equipment carried in or on the vehicle or combination and required for its normal operation, and
 - (iii) personal items used by a driver of the vehicle or combination, and
 - (iv) anything normally removed from the vehicle or combination when not in use.

vehicle includes the vehicle's equipment and substances the vehicle is carrying essential for its operation.

wheel includes a group of wheels that are mounted on an axle and are on one side of the longitudinal centreline of the vehicle.

52 Use of vehicle in contravention of dimension, mass or load restraint requirements

- (1) A person must not drive, or cause to be driven, along a road a light vehicle or light combination contravening a dimension, mass or load restraint requirement imposed by this Part otherwise than in accordance with a permit issued under clause 62.
Maximum penalty—30 penalty units.
- (2) In this clause, **dimension requirement**, **mass requirement** and **load restraint requirement** have the same meanings as in the Act, Schedule 1, clause 7.

Division 2 Mass limits for certain motor lorries and certain trailers

53 Definitions

- (1) In this Division—

existing motor lorry means a motor lorry for which—

- (a) a New South Wales registration was in force on 1 January 1995, and
- (b) registration has continued in force from 1 January 1995.

visiting motor lorry means a motor lorry temporarily in New South Wales.

- (2) For the purposes of the definition of **existing motor lorry** in subclause (1), registration is taken to have continued in force if the registration is continued without a break by—
 - (a) renewal or reissue of the registration, or
 - (b) transfer of the registration to another person.

54 Application of Division

- (1) This Division applies to motor lorries, including articulated vehicles.
- (2) This Division does not apply to the following—
 - (a) a caravan,
 - (b) a station wagon,
 - (c) a trailer that—
 - (i) weighs not more than 250 kilograms when unladen, and
 - (ii) is used principally or solely for carrying camping equipment, a boat or other materials used in connection with tours for recreational purposes, and
 - (iii) is not used while carry on trade or business,
 - (d) an excavator, road grader, road roller, bulldozer or other machinery or apparatus, that cannot carry a load other than the tools, spare parts, fuel, water, oil or other accessories, used in connection with the vehicle.
- (3) This Division does not authorise a person to drive or use a motor lorry, or cause a motor lorry to be driven or used, in contravention of a provision of the Act or the statutory rules.

55 Mass limit not to be exceeded

- (1) A person must not drive a motor lorry on a road if the total mass of the motor lorry exceeds the lorry's mass limit.
- (2) A person does not contravene this clause if—
 - (a) the motor lorry is driven in accordance with—
 - (i) the prior written permission of Transport for NSW, and
 - (ii) the conditions, if any, applying to the permission, and
 - (b) a copy of the permission is carried by the driver of the motor lorry when driving the lorry.

56 Mass limits for motor lorries other than existing motor lorries

- (1) For the purposes of this Division, the **mass limit** of a motor lorry that is not an existing motor lorry is—
 - (a) if the lorry is an articulated vehicle—the GCM of the motor lorry, and
 - (b) if the lorry is not an articulated vehicle—the GVM of the motor lorry.
- (2) For the purposes of subclause (1), the GCM or GVM of a motor lorry not altered since manufacture is the mass recorded for the type of motor lorry by Transport for NSW as the GCM or GVM, respectively.

- (3) However, for the purposes of subclause (1), the GCM for a motor lorry that is an articulated vehicle is 1.67 times the GVM recorded for the vehicle if—
 - (a) Transport for NSW has not recorded a GCM for the articulated vehicle, and
 - (b) Transport for NSW has recorded a GVM for its type of prime mover as a standard table top motor lorry.
- (4) The mass limit of a motor lorry is that determined under clause 58 if—
 - (a) the motor lorry has been altered since manufacture, or
 - (b) the motor lorry has not been altered since manufacturer, but to which no mass limit applies under subclause (2) or (3).
- (5) The mass limit of a visiting motor lorry is determined in accordance with the law for the time being in force in the State or Territory where the lorry is registered if—
 - (a) the visiting motor lorry has been altered since manufacture, or
 - (b) the visiting motor lorry has not been altered since manufacturer, but to which no mass limit applies under subclause (2) or (3).

57 Mass limits for existing motor lorries

- (1) For the purposes of this Division, the *mass limit* of an existing motor lorry is its aggregate weight.
- (2) However, if the lorry has been altered since its aggregate weight was determined, the mass limit of the lorry is to be the mass limit determined under clause 58.
- (3) In this clause—

aggregate weight, for an existing motor lorry, means the aggregate weight in force for the lorry immediately before 1 January 1995 under the *Motor Traffic Regulations 1935*, Regulation 120A, as in force immediately before 1 January 1995.

58 Determination of different mass limits

- (1) This clause applies to a motor lorry that is not a visiting motor lorry.
- (2) Transport for NSW may determine a mass limit for a motor lorry—
 - (a) if the lorry is not an existing motor lorry and no mass limit applies to the lorry under clause 56(3) or (4), or
 - (b) if the lorry is an existing motor lorry and has been altered as referred to in clause 57(3), or
 - (c) if the mass limit of the motor lorry applying under an earlier determination under this clause is no longer in accordance with the safe working limits of the motor lorry, or
 - (d) on application by the responsible person for the motor lorry, if Transport for NSW is satisfied the safe loading limits of the motor lorry have been altered.
- (3) A determination under this clause must be based on the construction and componentry of the lorry.
- (4) Transport for NSW must notify the responsible person for a motor lorry of—
 - (a) a determination made in relation to the lorry, and
 - (b) a refusal of an application by the responsible person under subclause (2)(d).
- (5) A determination under this clause takes effect on the later of the following—
 - (a) the date on which notice of the determination is served on the responsible person for the motor lorry,

- (b) the date specified in the notice.

59 TfNSW may require information or certificate

- (1) Transport for NSW may, by written notice to the responsible person for a motor lorry, require the responsible person to provide Transport for NSW with the information about the motor lorry or its equipment specified in the notice.
- (2) The responsible person must provide the information within the period specified by Transport for NSW in the notice.
- (3) If Transport for NSW determines a mass limit for a motor lorry under clause 58, Transport for NSW—
 - (a) may require the responsible person to forward the lorry's certificate of registration to Transport for NSW, and
 - (b) may—
 - (i) endorse the mass limit on the forwarded certificate of registration, or
 - (ii) cancel and reissue the certificate of registration with the mass limit endorsed on the reissued certificate, and
 - (c) must forward the certificate of registration to the responsible person once it has endorsed or reissued the certificate.
- (4) A responsible person for a motor lorry must not fail to comply with a requirement under this clause without reasonable excuse.
Maximum penalty—20 penalty units.

Division 3 Dimension requirements

60 Projection of loading or equipment of vehicles

- (1) A person must not drive on a road—
 - (a) a motor vehicle, not being a motor bike or a mobile crane 9.5 metres or less in length, if the loading or equipment on the vehicle or trailer drawn by the vehicle projects—
 - (i) more than 150 millimetres beyond the extreme outer portion of either side of the vehicle or trailer, or
 - (ii) if the vehicle is a mobile crane—more than 3.5 metres in front of the steering wheel of the vehicle, or
 - (iii) if the vehicle is not a mobile crane—more than 1.2 metres in front of the headlights of the motor vehicle, or
 - (iv) if the vehicle does not exceed 9.5 metres in length or a trailer—more than 1.2 metres to the rear of the motor vehicle or trailer, except as provided by subclause (3), or
 - (v) if the vehicle exceeds 9.5 metres in length—to the rear of the vehicle beyond a point 4 metres from the rear overhang line, or
 - (b) a motor bike without a sidecar attached if the loading or equipment on the motor bike projects—
 - (i) more than 150 millimetres in front of the outer extremity of the front wheel, or
 - (ii) more than 300 millimetres behind the outer extremity of the rear wheel, or
 - (iii) beyond the extreme outer portion of the motor bike on either side, or
 - (c) a motor bike with a sidecar attached if—

public consultation draft

Road Transport (General) Regulation 2021 [NSW]

Part 4 Mass, dimension and load requirements for light vehicles and light combinations

- (i) a part of the vehicle or its loading or equipment projects more than 600 millimetres in front of the outer extremity of the front wheel or more than 900 millimetres behind the outer extremity of the rear wheel of the motor bike, or
 - (ii) a part of the vehicle or its loading or equipment projects more than 900 millimetres behind the outer extremity of the rear wheel of the motor bike, or
 - (iii) the loading or equipment projects beyond the extreme outer portion of the vehicle on either side, or
 - (d) an articulated vehicle first registered on or after 1 January 1960, not being a vehicle to which a pole-type trailer is attached, if a part of the semi-trailer or its loading or equipment projects more than 1.9 metres radially forward of the axis of the pivot pin, or
 - (e) an articulated vehicle exceeding 19 metres in length, or
 - (f) a motor vehicle and trailer combination exceeding 19 metres in length.
- (2) Subclause (1)(a)(i) does not apply to a rear vision mirror, signalling device, side mounted lamp or tyre pressure monitoring system permitted by the *Road Transport (Vehicle Registration) Regulation 2017* to be fitted to the vehicle.
- (3) It is not a contravention of subclause (1)(a)(iii) for loading or equipment to project more than 1.2 metres to the rear of a motor vehicle or trailer drawn by the vehicle if—
- (a) the overall length of the vehicle or of the combination of vehicle and trailer, together with the loading or equipment on it, is within the relevant limit fixed by the *Light Vehicle Standards Rules*, and
 - (b) there is carried at the extreme rear of the loading or equipment a red flag or other suitable object that—
 - (i) is not less than 300 millimetres square, and
 - (ii) is kept clearly visible as a warning to persons on the roadway nearby by the vehicle or trailer, and
 - (c) between the hours of sunset and sunrise, or when there is insufficient daylight to render a person dressed in dark clothing clearly discernible at a distance of 100 metres, there is attached at the extreme rear of the loading or equipment—
 - (i) a lighted lamp showing a clear red light to the rear, visible under normal atmospheric conditions at a distance of 200 metres, or
 - (ii) at least two reflectors capable of projecting a red reflection of light from the light of a following vehicle.
- (4) For the purpose of subclauses (1)(a)(iii) and (2), **equipment** includes the pole of a pole-type trailer.
- (5) If a portion of the loading or equipment of a motor vehicle, or of a trailer drawn by the vehicle, projects in a way not readily visible to a person following immediately behind the vehicle, the driver of the vehicle must—
- (a) mark the end of the loading or equipment by a red flag or other suitable object that—
 - (i) is not less than 300 millimetres square, and
 - (ii) is kept clearly visible to persons nearby, and
 - (b) between the hours of sunset and sunrise or when there is insufficient daylight to render a person dressed in dark clothing discernible at a distance of 100 metres, cause to be attached to the extreme rear of the loading or equipment the lighted lamp or reflectors referred to in subclause (3)(c).

- (6) In this clause—
centre of an axle group means—
- (a) a line located midway between the centrelines of the outermost axles of the group, or
 - (b) if the group consists of 2 axles, one of which is fitted with twice the number of tyres as the other axle—a line located one third of the way from the centreline of the axle with more tyres towards the centreline of the axle with fewer tyres.

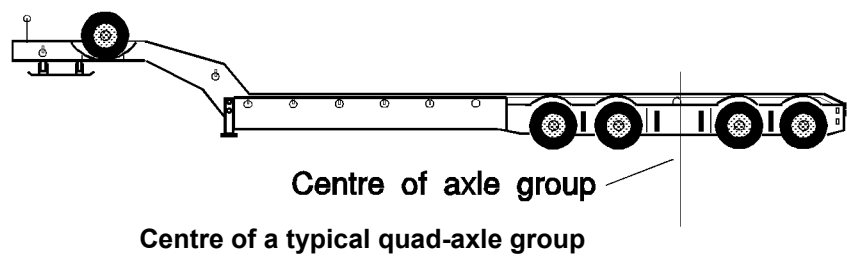
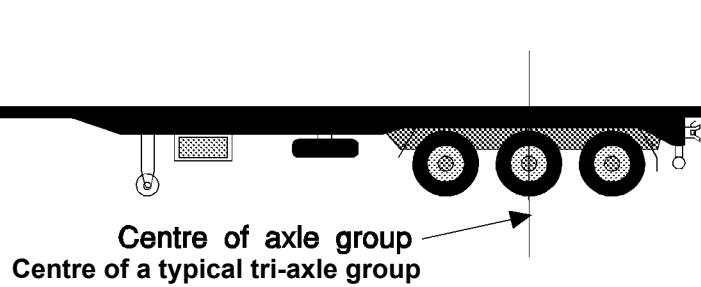
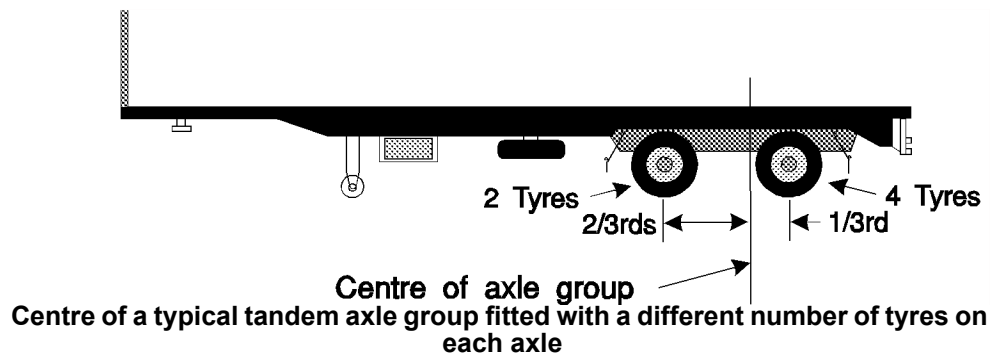
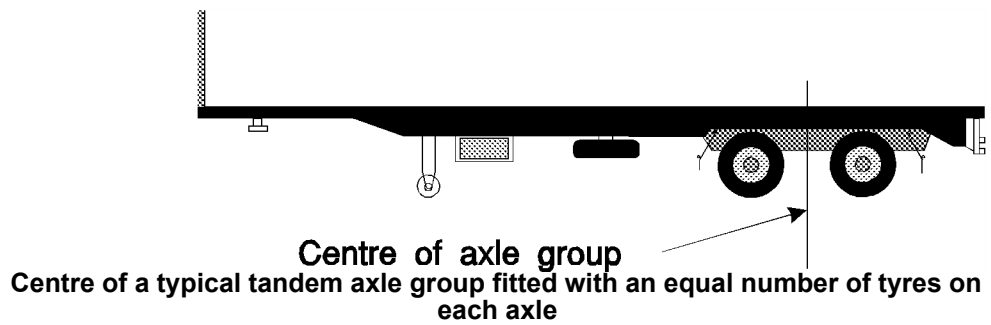

pole-type trailer means a trailer that—

- (a) is attached to a towing vehicle by a pole or an attachment fitted to a pole, and
- (b) is ordinarily used for transporting loads, for instance logs, pipes, structural members or other long objects, generally capable of supporting themselves like beams between supports.

Note. A pole-type trailer is also known as a jinker.

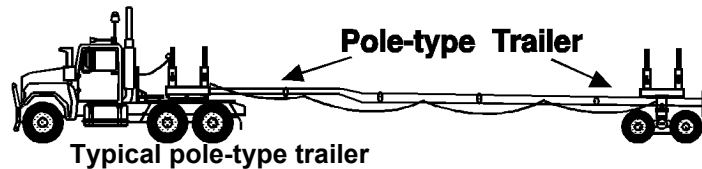

rear overhang line means—

- (a) if there is a single axle at the rear of the vehicle—the centreline of the axle, or
- (b) if there is an axle group at the rear of the vehicle—the centre of the axle group, determined without regard to the presence of any steerable axle or retractable axle in the group unless all axles in the group are steerable or retractable.

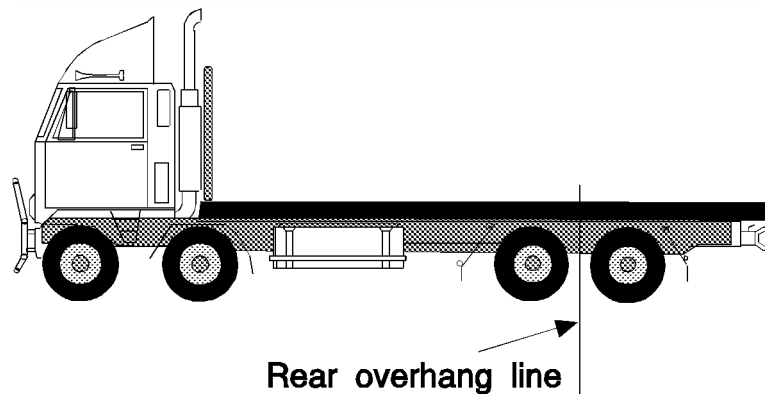

Rear overhang line on a typical motor vehicle with an axle group

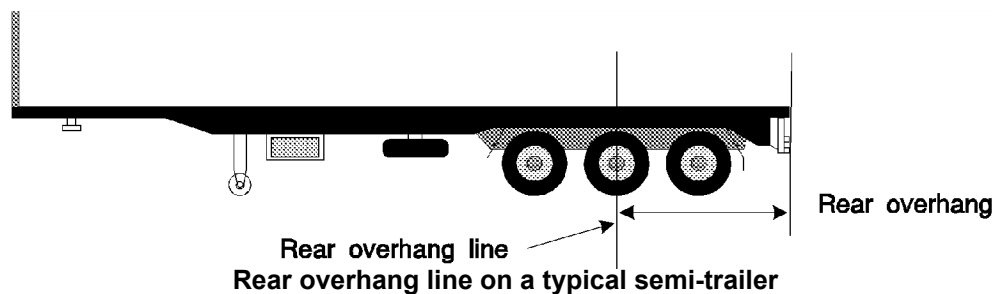

Rear overhang line on a typical semi-trailer

retractable axle means an axle that can be raised so the tyres on the axle do not touch the ground.

61 Exemption by notice in Gazette

- (1) Transport for NSW may, by notice published in the Gazette, exempt a person or class of persons from the operation of a provision of clause 60(1).
- (2) The notice must specify—
 - (a) the conditions of the exemption, if any, and

- (b) how long it is to remain in force.

62 Exemption by permit

- (1) Transport for NSW may, on application by a person, issue a permit exempting the person from the operation of a provision of clause 60(1).
- (2) An application for a permit must—
 - (a) be in writing and in a form approved by Transport for NSW, and
 - (b) be accompanied by the fee specified in Schedule 1.
- (3) The permit must set out any conditions of the exemption, if any.
- (4) Transport for NSW may, if it considers it appropriate to do so, waive or refund payment of all or part of a fee payable under this clause.

Division 4 Other mass and dimension requirements

63 Special mass limits

- (1) A roads authority may, by written notice, fix a maximum axle load, maximum loaded mass or other load limit for a vehicle—
 - (a) if the provisions of this Part do not apply to the vehicle, or
 - (b) in a special case.
- (2) The notice must be—
 - (a) given to the responsible person for the vehicle to which it applies, or
 - (b) published in the Gazette or in a local newspaper circulated in the locality to which the notice applies.
- (3) A load or limit fixed by a notice is taken to be imposed by this Part.
- (4) A person must not fail to comply with the terms of a notice.

64 Mass limits for three-wheeled vehicles

A person must not drive a three-wheeled motor vehicle on a road if the mass of the load of the vehicle exceeds the mass the vehicle is capable of carrying as stated in the certificate of registration for the vehicle.

Maximum penalty—20 penalty units.

65 Lower limit to apply if multiple mass requirements

If more than one mass limit applies to a vehicle or combination, or part of a vehicle or combination, the lower mass limit must be complied with.

66 Load requirements

- (1) A load on a vehicle or a trailer must not be placed in a way making the vehicle unstable or unsafe.
- (2) A load on a vehicle or a trailer must be secured so it is unlikely to fall or be dislodged from the vehicle.
- (3) An appropriate method must be used to restrain the load on a vehicle.
- (4) In proceedings for a contravention of a requirement under this clause, it is sufficient for the prosecution to prove the load on the vehicle was not placed, secured or restrained in a way meeting the performance standards recommended in the Load Restraint Guide.

- (5) In proceedings for a failure to comply with this clause, a document purporting to be the Load Restraint Guide is taken to be the Load Restraint Guide, unless the document is proved by the defendant not to be the Load Restraint Guide.
- (6) If the prosecution in proceedings for a contravention of a requirement under subclause (2) proves the load, or part of the load, had fallen off the vehicle, the burden of proof is on the defendant to show compliance.
- (7) In this clause—
Load Restraint Guide means the *Load Restraint Guide for Light Vehicles 2018*, published by the National Transport Commission and in force from time to time.
Note. The Load Restraint Guide is available on the National Transport Commission's website (www.ntc.gov.au).

67 Driver to have sufficient control

A person must not drive a motor vehicle on a road—

- (a) if the vehicle is constructed, equipped or loaded, or if anything is attached to the vehicle, in a way preventing the person from having a view—
 - (i) of traffic on either side of the vehicle, or
 - (ii) in all directions in front of the vehicle, or
 - (iii) enabling the driver to drive the vehicle safely, or
- (b) if the vehicle is motor bike constructed, equipped or loaded, or if anything is attached to the motor bike, in a way preventing the driver from having a view of the approach of an overtaking vehicle, or
- (c) if the person is prevented from safely driving or controlling the motor vehicle, or trailer or other vehicle attached to the motor vehicle, because of—
 - (i) the weight or dimensions of the loading or equipment of the towing vehicle, trailer or other towed vehicle, or
 - (ii) the manner in which the loading or equipment is placed on or attached to the towing vehicle, trailer or other towed vehicle.

Maximum penalty—20 penalty units.

Division 5 Checking and measuring procedures

68 Method of determining wheel loads

- (1) For the purpose of determining the wheel load of a wheel of a motor vehicle or a trailer, the wheel is to be weighed in a way so that the wheel or wheels are weighed together with the portion of the vehicle and load supported by the wheel or wheels.
- (2) For the purposes of subclause (1), the wheel may weighed—
 - (a) alone, or
 - (b) together with another wheel or wheels forming an axle group of which the wheel being weighed forms part.
- (3) If a wheel is weighed together with other wheels, the wheel load of the wheel being determined is the mass of all the wheels weighed divided by the number of wheels weighed.
- (4) In this Division, **wheel load** means the mass transmitted to the road by a wheel.

69 Method of determining axle loads

For the purpose of determining the axle load of an axle or axle group of a motor vehicle or trailer, either of the following methods may be used—

- (a) the wheel loads of all wheels on the axle or in the axle group may be added together,
- (b) if the mass of the vehicle, together with a load that it supports, is known—the axle loads of all single axles and all the axle groups, other than the axle or group the load of which is being determined, are to be subtracted from the mass.

70 Method of determining total mass

For the purpose of determining the total mass of a vehicle or combination, either of the following methods may be used—

- (a) the axle loads of all the single axles and all the axle groups of the vehicle or combination may be added together,
- (b) all the wheels of the vehicle or combination, together with the vehicle and added loads supported by the wheels, may be weighed simultaneously on a weighing device or weighing devices.

71 Weighing devices

- (1) This clause applies to a weighing device used for the purpose of determining a wheel load, an axle load or a total mass in accordance with this Part.
- (2) If the weighing device shows a mass in excess of the weight for which the device has been verified under the *National Measurement Act 1960* of the Commonwealth, the load on the device is, for the purposes of this Part, taken to be the weight for which the weighing device has been verified.

Division 6 Miscellaneous

72 Keeping documents

- (1) The driver of a vehicle or a combination must carry in the driving compartment—
 - (a) a copy of a notice or permit given under this Part under which the vehicle or the combination is operating, or
 - (b) an information sheet setting out the obligations imposed under the notice or permit.

Maximum penalty—30 penalty units.

- (2) Subclause (1) does not apply if the notice or permit states the subclause does not apply.
- (3) In this clause—
information sheet means advice published or adopted by Transport for NSW and available on request from Transport for NSW.

73 Exemptions in emergencies

- (1) In an emergency, for example a fire, explosion or natural disaster, Transport for NSW may exempt a vehicle or combination, or its driver or responsible person for the vehicle, from a requirement of this Part if—
 - (a) the vehicle or combination is being used, or is intended to be used—
 - (i) to protect life or property, or
 - (ii) to restore communication services, or
 - (iii) to restore energy or water services, or services including sewage disposal, or
 - (iv) to provide drought relief, and

public consultation draft

Road Transport (General) Regulation 2021 [NSW]

Part 4 Mass, dimension and load requirements for light vehicles and light combinations

- (b) the exemption does not present an unreasonable danger to other road users.
- (2) An exemption may be subject to conditions imposed by Transport for NSW.
- (3) Transport for NSW—
 - (a) must make a written record of the exemption and its conditions, and
 - (b) may cause the exemption and conditions to be communicated orally to the driver or responsible person.

Part 5 Road transportation

Division 1 Monitoring of heavy vehicles and vehicles carrying dangerous goods

74 Vehicles to which the Act, Part 6.1 applies, in addition to vehicles carrying dangerous goods

For the purposes of the Act, section 150(1)(a), the following vehicles are prescribed—

- (a) all classes and descriptions of coaches,
- (b) a heavy motor vehicle that is an articulated vehicle or a prime mover.

75 Prescribed officers for the purposes of the Act, Part 6.1

(1) For the purposes of the Act, Part 6.1, the following persons are authorised as prescribed officers—

- (a) officers employed by Transport for NSW as enforcement officers and to whom Transport for NSW has issued a written authorisation for the purposes of this Division,
- (b) officers of SafeWork NSW who are employed as inspectors of dangerous goods,
- (c) authorised officers within the meaning of the *Dangerous Goods (Road and Rail Transport) Act 2008*.

(2) For the purposes of the Act, section 154(4)(b), the prescribed manner of identification is—

- (a) for a prescribed officer employed by Transport for NSW—wearing a uniform of Transport for NSW, or
- (b) for a prescribed officer employed by SafeWork NSW—wearing a reflectorised vest displaying the words “SAFETY OFFICER”, or
- (c) for a prescribed officer referred to in subclause (1)(c)—wearing a reflectorised vest displaying the letters “EPA”.

76 Manner of approval of aspects of data recording and related matters

An approval of Transport for NSW for the purposes of Part 6.1 of the Act is to be signified in one of the following ways—

- (a) in a Vehicle Monitoring Device Specification published or adopted by Transport for NSW and available on request from Transport for NSW,
- (b) by written instrument—
 - (i) signed by a person who has received written authorisation from Transport for NSW to give the approval, and
 - (ii) given to a person seeking to rely on the approval.

77 Accessories to contravention of the Act, Part 6.1

A person must not knowingly cause, permit or allow another person to contravene a provision of the Act, Part 6.1.

Maximum penalty—20 penalty units.

78 Manner of granting exemptions

(1) For the purposes of the Act, section 158(1), an exemption may be granted—

- (a) by order published in—

- (i) the Gazette, or
 - (ii) a newspaper circulating in New South Wales, or
- (b) by written notice—
 - (i) signed by a person who has received written authorisation from Transport for NSW to give the exemption, and
 - (ii) given to the person who is, or whose vehicle is, to be exempted.
- (2) An exemption granted in the manner provided by subclause (1)(b) may in the same manner be rescinded.

Note. In relation to subclause (1)(a), the *Interpretation Act 1987*, section 43(2) provides that if an Act or statutory rule confers a power on a person or body to make an order, whether or not the order must be in writing, the power includes power to amend or repeal an order made in the exercise of the power.

Division 2 Speed limiters

79 Application of the Act, Part 6.2

For the purposes of the Act, section 161(1), the following vehicles are prescribed as vehicles to which the Act, Part 6.2 applies—

- (a) a motor lorry, excluding a lorry to which the *Heavy Vehicle (Vehicle Standards) National Regulation (NSW)*, Schedule 2, Part 10 applies—
 - (i) manufactured on or after 1 January 1988, and
 - (ii) having a GVM exceeding 15 tonnes, or
- (b) a bus, excluding a bus to which the *Heavy Vehicle (Vehicle Standards) National Regulation (NSW)*, Schedule 2, Part 10 applies—
 - (i) manufactured on or after 1 January 1988, and
 - (ii) having a GVM exceeding 14.5 tonnes, and
 - (iii) used to provide a public passenger service, or
- (c) a motor lorry—
 - (i) manufactured on or after 1 January 1991, and
 - (ii) having a GVM exceeding 12 tonnes, or
- (d) a bus—
 - (i) manufactured on or after 1 January 1991, and
 - (ii) having a GVM exceeding 5 tonnes, and
 - (iii) used to provide a public passenger service.

80 Manner of limiting speed

- (1) For the purposes of the Act, Part 6.2, the manner of limiting the speed of a vehicle is—
 - (a) if the vehicle was manufactured on or after 1 January 1989—the manner prescribed by the third edition ADR for vehicles of the type, and
 - (b) if the *Heavy Vehicle (Vehicle Standards) National Regulation (NSW)*, Schedule 2, Part 10 applies to the vehicle—the manner prescribed in Part 10, and
 - (c) if the vehicle is not a vehicle referred to in paragraph (a) or (b)—the manner prescribed by an order made by Transport for NSW and published in the Gazette.
- (2) In this clause—

third edition ADR has the same meaning as it has in the Light Vehicle Standards Rules.

81 Modifications

- (1) Transport for NSW or a police officer may serve a notice under this clause on the responsible person for a vehicle to which the Act, Part 6.2 applies if Transport for NSW or the police officer has reason to believe the vehicle is capable of being driven at a speed exceeding 105 kilometres per hour.
- (2) Transport for NSW or a police officer may serve a notice under this clause on the person who, at the time of the offence or alleged offence concerned, was the responsible person for a vehicle to which the Act, Part 6.2 applies—
 - (a) if—
 - (i) a driver of the vehicle has been convicted of an offence arising out of a contravention of clause 4 while driving the vehicle, and
 - (ii) it was found by the court that, at the time of the offence, the driver was driving the vehicle at a speed exceeding 105 kilometres per hour, or
 - (b) if—
 - (i) a driver of the vehicle has paid a penalty prescribed for the purposes of the Act, section 195 in relation to an alleged offence so arising, and
 - (ii) the police officer or authorised officer who issued the relevant penalty notice indicated on the notice that, at the time of the alleged offence, the driver was driving the vehicle at a speed exceeding 105 kilometres per hour, or
 - (c) if—
 - (i) a penalty notice enforcement order under the *Fines Act 1996* has been made, or is taken to have been made, against a driver of the vehicle in relation to an alleged offence so arising, and
 - (ii) the police officer or authorised officer who issued the relevant penalty notice indicated on the notice that, at the time of the alleged offence, the driver was driving the vehicle at a speed exceeding 105 kilometres per hour.
- (3) A notice under this clause may require the responsible person on whom the notice was served to—
 - (a) make alterations to the vehicle so the speed at which it is capable of being driven is limited, in the manner prescribed for the purposes of the Act, Part 6.2, to not more than 100 kilometres per hour, and
 - (b) supply information concerning the alterations made to the vehicle as the notice indicates, and
 - (c) have the vehicle tested to determine whether the vehicle's speed is limited in accordance with the Act, Part 6.2, and to provide a certificate to that effect in the manner and form specified in the notice.

82 Authorised person for certification of speed limiter compliance

A person who is authorised to inspect, service, repair and certify the proper working of a speed limiting mechanism fitted to a vehicle by the manufacturer of the speed limiting mechanism is prescribed for the purposes of the Act, section 163(2), definition of *authorised person*.

83 Exemptions

- (1) Transport for NSW may exempt a person or vehicle from a specified provision of clause 79 or 80—
 - (a) by order published in—
 - (i) the Gazette, or
 - (ii) a newspaper circulating in New South Wales, or
 - (b) by written notice—
 - (i) signed by a person who has received written authorisation from Transport for NSW to give the exemption, and
 - (ii) given to the person who is, or whose vehicle is, to be exempted.
- (2) An exemption may be unconditional or may be subject to conditions specified in the order or notice.
- (3) If an exemption is subject to conditions, the exemption ceases to have effect if a condition of the exemption is contravened.
- (4) An exemption granted in the manner provided by subclause (1)(b) may in the same manner be rescinded.

Note. In relation to subclause (1)(a), the *Interpretation Act 1987*, section 43(2) provides that if an Act or statutory rule confers a power on a person or body to make an order, whether or not the order must be in writing, the power includes power to amend or repeal an order made in the exercise of the power.

Part 6 Pay parking schemes

Division 1 Operation of pay parking schemes

84 Establishment of pay parking schemes

- (1) A parking authority may establish and operate a *pay parking scheme* for a road within its area of operations by—
 - (a) setting aside pay parking spaces or pay parking areas in a road within its area of operations in accordance with TfNSW guidelines, and
 - (b) fixing the fees for parking a vehicle in a pay parking space or pay parking area.
- (2) A parking authority may install devices for use in connection with payment of the fees (*pay parking device*).

85 Pay parking fees

- (1) The fees for parking in a pay parking space or pay parking area are to be fixed—
 - (a) if the parking authority is a council—by resolution of the council, and
 - (b) if the parking authority is a declared organisation—in accordance with pricing principles set out in TfNSW guidelines.
- (2) Different fees may be fixed for—
 - (a) different pay parking spaces, and
 - (b) different pay parking areas, and
 - (c) different days, and
 - (d) different times of the day.

86 Requirements for pay parking space, area or device

- (1) Subclause (2) sets out the information that must be displayed clearly—
 - (a) for a pay parking space—in, or in close proximity to, the pay parking space, or
 - (b) for a pay parking area—in the pay parking area, or
 - (c) for a pay parking device—on, or during the use of, the pay parking device.
- (2) The following information must be displayed—
 - (a) the fee, if any, fixed for the use of the pay parking space or pay parking area,
 - (b) the methods of payment that may be used to pay the fee,
 - (c) other information that may be set out in TfNSW guidelines for the purposes of this clause.

87 Duration of pay parking period

- (1) A *pay parking period* is the period of time during which a vehicle is authorised to park in a pay parking space or pay parking area because of payment of the fee for the parking.
- (2) A pay parking period commences on the date and time the pay parking period is initiated in accordance with the procedures of the parking authority.

88 Evidence of payment of parking fee

- (1) A person must not, in relation to a vehicle parked in a pay parking space or pay parking area, falsely represent the relevant parking fee has been paid.
Maximum penalty—20 penalty units.

- (2) For the purposes of this clause, ways in which a false representation is made include, but are not limited to, displaying in or on the vehicle—
 - (a) an article or thing resembling evidence of the payment of a relevant parking fee falsely suggesting the fee has been paid, or
 - (b) evidence of the pre-payment of a relevant parking fee that is altered, defaced, mutilated or illegible.

89 Damage to or misuse of pay parking devices

A person must not—

- (a) damage a pay parking device, or
- (b) deface a pay parking device,
- (c) affix anything, including advertising matter, to a pay parking device, or
- (d) do anything interfering with, or is likely to interfere with, the proper working of a pay parking device unless lawfully authorised to do so, or
- (e) fraudulently operate a pay parking device.

Maximum penalty—20 penalty units.

90 Temporary closure of pay parking space or pay parking area

- (1) A parking authority may, if it decides the use of a pay parking space or pay parking area should be temporarily discontinued, close the space or area.
- (2) A pay parking space or pay parking area is closed if a sign displaying words to the effect the space or area is temporarily closed is erected—
 - (a) for a pay parking space—in, or in close proximity to, the pay parking space, or
 - (b) for a pay parking area—in the pay parking area.
- (3) In this clause, a *pay parking area* includes part of a pay parking area.

Note. A driver who parks in a pay parking space or pay parking area that is temporarily closed under this clause may commit an offence against the *Road Rules 2014*, rule 207–7.

91 Trailers not separately chargeable

This Division does not require a separate parking fee to be paid for a trailer drawn by another vehicle if the trailer remains attached to the vehicle while the vehicle is parked.

Division 2 Miscellaneous

92 Councils' common pay parking schemes

- (1) A council may, in accordance with TfNSW guidelines, agree with one or more other councils concerning the operation of pay parking schemes on a common payment basis.
- (2) The councils must, by resolution, fix fees on a common basis to be charged for parking in the pay parking schemes covered by the agreement.

93 TfNSW guidelines

- (1) Transport for NSW may establish TfNSW guidelines for the purposes of this Part.
- (2) Transport for NSW must publish the TfNSW guidelines—
 - (a) on a publicly accessible website maintained by Transport for NSW, or
 - (b) if the website referred to in paragraph (a) is not available—on a publicly accessible government website.

- (3) To the extent a provision of this Regulation requires a parking authority to comply with TfNSW guidelines, a parking authority is not entitled to provide or charge for parking in a pay parking space or pay parking area if it fails to comply with the guidelines.
- (4) For the purposes of this clause, a parking authority is taken to have complied with the TfNSW guidelines until the contrary is proved.

94 Other powers to provide pay parking

- (1) This Part does not affect other powers of a parking authority to provide for parking on land within its area of operations.
- (2) A parking authority may only exercise a power under this Part in relation to land it does not own with the consent of the owner of the land.
- (3) The consent of the owner of the land—
 - (a) may be given subject to terms and conditions, including terms for the duration and revocation of the consent, and
 - (b) may be revoked only—
 - (i) in accordance with the terms for the revocation of the consent, or
 - (ii) otherwise—after giving reasonable notice.

95 Overlapping schemes

- (1) This Part does not prevent a parking authority from establishing and operating a pay parking scheme on a road on which it is operating another pay parking scheme.
- (2) However, a parking authority must not recover a relevant parking fee fixed for a vehicle parking in a pay parking area if another relevant parking fee has been paid for the vehicle.

96 Application of money from parking

- (1) The costs of administering a pay parking scheme are to be borne by the parking authority.
- (2) The costs are taken to include the following—
 - (a) the cost of providing, controlling, maintaining and regulating pay parking,
 - (b) the cost of providing, controlling, maintaining and regulating pay parking devices installed in relation to a pay parking space or pay parking area,
 - (c) the cost of providing and maintaining signs or other devices and marking lines—
 - (i) to indicate the position of a pay parking space or pay parking area, or
 - (ii) to indicate the places in a road where a vehicle, other than a public vehicle, may park.
- (3) A parking authority must pay to Transport for NSW the amount agreed between Transport for NSW and the parking authority for the costs referred to in subclause (2)(c).
- (4) Subject to clause 92, fees a parking authority collects in relation the operation of pay parking belong to the parking authority.
- (5) Any surplus arising from the operation of pay parking may be applied at the discretion of the parking authority.

97 Disputes

- (1) A dispute arising under this Part between a parking authority and Transport for NSW is to be resolved by consultation between—
 - (a) the Minister responsible for the parking authority, and
 - (b) the Minister administering the Act.
- (2) A dispute arising under this Part between 2 or more parking authorities is to be resolved—
 - (a) if the same Minister is responsible for each parking authority—by the Minister, or
 - (b) otherwise—by consultation between the Ministers responsible for the parking authorities.
- (3) If agreement cannot be reached by consultation, the dispute must be resolved by the Premier.
- (4) In this clause, a reference to the Minister responsible for a parking authority is a reference to—
 - (a) for a council—the Minister administering the *Local Government Act 1993*, and
 - (b) for a declared organisation constituted by or under an Act— the Minister administering that Act, and
 - (c) for a government department—the Minister responsible for the department.

98 Powers of police in emergency or obstruction or danger to traffic

- (1) A police officer may, during a temporary obstruction or danger to traffic, or in an emergency—
 - (a) direct a person not to cause or permit a vehicle to park in a pay parking space or pay parking area, or
 - (b) direct the responsible person for, or driver of, a vehicle parking in a pay parking space or pay parking area to remove the vehicle from the space or area, or
 - (c) if no person appears to be in charge of a vehicle parked in a pay parking space or pay parking area—remove the vehicle from the space or area.
- (2) A person must not, without reasonable excuse, fail to comply with a direction under this clause.
Maximum penalty—20 penalty units.
- (3) In this clause—
pay parking area includes a part of a pay parking area.

Part 7 Mobility parking scheme authorities

Division 1 Preliminary

99 Definitions

In this Part—

holder of a scheme authority, or an expired or revoked scheme authority, means the person or organisation to whom or to which the scheme authority has been or was issued.

interstate or overseas authority means a document issued by an authority of another jurisdiction, or of a foreign country, to indicate—

- (a) a specified person is a disabled person who has the benefit of parking concessions in the jurisdiction or country, or
- (b) a specified vehicle is used for the purpose of conveying disabled persons and has the benefit of parking concessions in the jurisdiction or country.

mobility parking scheme means the scheme for the issue of scheme authorities set out in this Part.

organisation means a corporation or an unincorporated association of persons.

scheme authority means a mobility parking scheme authority issued under this Part.

Division 2 Issue of scheme authorities

100 TfNSW may issue mobility parking scheme authorities

Transport for NSW may, on application under this Part, issue a mobility parking scheme authority—

- (a) for use by a disabled person, or
- (b) for use by an organisation in connection with the conveyance of disabled persons.

101 Form of scheme authority

- (1) A scheme authority must show the following—
 - (a) a unique identifying number allocated by Transport for NSW,
 - (b) the full name of the holder of the scheme authority,
 - (c) the category of scheme authority issued,
 - (d) the expiry date of the scheme authority.
- (2) A scheme authority may also show the following—
 - (a) a photograph of the individual to whom it has been issued,
 - (b) the date of birth of the individual to whom it has been issued,
 - (c) the signature, or a reproduction of the signature, of an individual to whom it has been issued,
 - (d) the home, business or other address for service of the holder of the scheme authority,
 - (e) other information Transport for NSW considers appropriate.
- (3) A scheme authority may be categorised and colour coded as follows—
 - (a) for an individual authority for a disabled person—blue,
 - (b) for a temporary authority for a disabled person with a temporary disability—red,

- (c) for an organisational authority for the conveyance of disabled persons—green.

102 When scheme authority ceases to be in force

A scheme authority ceases to be in force on the expiry of the scheme authority unless it is sooner revoked by Transport for NSW under this Part.

Division 3 Applications for scheme authorities

103 Procedure to obtain scheme authority

- (1) The applicant for a scheme authority must be—
 - (a) if the application is for an individual—
 - (i) the individual, or
 - (ii) a person Transport for NSW is satisfied acts on behalf of the individual, or
 - (b) if the application is for an organisation—an individual authorised in writing by the organisation, or the governing body of the organisation, to apply for the scheme authority on its behalf.
- (2) An applicant for the issue of a scheme authority must give Transport for NSW the following—
 - (a) a completed application form in the form approved by Transport for NSW,
 - (b) particulars necessary to identify the applicant and the applicant's home or business address for service, including evidence Transport for NSW may reasonably require to verify those particulars,
 - (c) documents or other evidence specified by the application form,
 - (d) the fee, if any, fixed under clause 104 for the category of scheme authority applied for,
 - (e) if the application is for an individual—evidence, in a form specified by Transport for NSW, that satisfies Transport for NSW the individual—
 - (i) is a disabled person, and
 - (ii) a resident of New South Wales,
 - (f) if the applicant is making the application on behalf of an individual or organisation—
 - (i) evidence specified by the application form or otherwise required by Transport for NSW confirming the applicant's authority to make the application, and
 - (ii) particulars necessary to identify the individual or organisation on behalf of whom or which the application is made, including the individual's or organisation's home, business or other address for service, and
 - (iii) evidence Transport for NSW may reasonably require to verify the particulars of the individual or organisation.
- (3) An address for service given under subclause (2) must be within New South Wales.

104 Application fees

- (1) Transport for NSW may, by order published in the Gazette, fix fees, or amend or revoke fees, for services provided by Transport for NSW in connection with the issue of scheme authorities.
- (2) Without limiting subclause (1)—
 - (a) different fees may be fixed for different categories of authorities, and

- (b) different fees may be fixed for different categories of applicants.
- (3) In fixing a fee under subclause (1), Transport for NSW must have regard to the following—
 - (a) the costs, including the estimated costs, associated with the establishment and administration of the mobility parking scheme over the period determined by Transport for NSW (the *specified administration period*),
 - (b) the actual or estimated number of applicants for scheme authorities and participants in the mobility parking scheme during the specified administration period,
 - (c) increases in the Consumer Price Index (All Groups Index) for Sydney issued by the Australian Bureau of Statistics in the latest published series of the index.
- (4) Transport for NSW may, in a particular case—
 - (a) waive the requirement for a fee, or
 - (b) reduce a fee.

105 Surrender of current or expired scheme authority if applying for new authority

- (1) An applicant for a new scheme authority must surrender a current scheme authority or expired scheme authority to Transport for NSW before a new scheme authority is issued.
- (2) Despite subclause (1), Transport for NSW may exempt a person from surrendering the current or expired scheme authority if Transport for NSW is satisfied it would be unreasonable, in the circumstances, to require the authority to be surrendered.

Division 4 Collection and use of information

106 Information about eligibility for and use of scheme authority

- (1) Transport for NSW may give a holder of a scheme authority written notice requiring the holder to provide, in the form specified in the notice, with evidence that satisfies Transport for NSW—
 - (a) the scheme authority has not been misused in the way or circumstances described in the notice, or
 - (b) if the holder is an individual—the individual is—
 - (i) a disabled person, or
 - (ii) a resident of New South Wales, or
 - (c) if the holder is an organisation—the organisation—
 - (i) continues to provide services for the conveyance of disabled persons in New South Wales, or
 - (ii) has its address for service in New South Wales.
- (2) The holder of the scheme authority must comply with the notice.
Maximum penalty—20 penalty units.

107 Evidence of disability

For the purposes of satisfying itself under clause 103, 106 or 108 an individual is a disabled person, Transport for NSW may require the individual—

- (a) to be examined by—
 - (i) a specified medical practitioner, or

- (ii) a medical practitioner belonging to a specified class of medical practitioners, and
- (b) to authorise the medical practitioner to provide Transport for NSW with information Transport for NSW may require in relation to the individual's disability.

108 Change and verification of details of scheme authority holder

- (1) A holder of a scheme authority must notify Transport for NSW, not more than 14 days after the change, about a change in the holder's—
 - (a) name, or
 - (b) residential address, or
 - (c) if the holder is an individual—status as a disabled person.Maximum penalty—20 penalty units.
- (2) If there are reasonable grounds for believing information held by Transport for NSW for the administration of the mobility parking scheme is inaccurate or misleading, Transport for NSW may, by written notice, require the holder of a scheme authority to confirm one or more of the following within 21 days of the giving of the notice—
 - (a) the holder's name, or
 - (b) the holder's residential address, or
 - (c) if the holder is an individual—the holder's status as a disabled person.
- (3) The holder of the scheme authority must comply with the notice.
Maximum penalty—20 penalty units.

109 Information collected under Division 3 or 4

- (1) Transport for NSW may collect, keep, use and disclose information provided under this Division or Division 3 for the purposes of—
 - (a) carrying out its functions under this Part, or
 - (b) the prosecution of an offence under this Part.
- (2) Despite subclause (1), evidence provided under clause 106(1) may only be used to prosecute a person for an offence in relation to the falsity of the evidence provided by the person.

Division 5 Photographs

110 TfNSW may require the taking of photographs

- (1) Transport for NSW may require an applicant for a scheme authority to have the applicant's photograph taken.
- (2) However, Transport for NSW must not require an applicant for a scheme authority to have the applicant's photograph taken if Transport for NSW is satisfied—
 - (a) the applicant is under 16 years of age, or
 - (b) the applicant suffers from a significant facial disfigurement, or
 - (c) the applicant cannot attend a registry to be photographed because of the severity of the applicant's disabilities.
- (3) For the purpose of making a determination under subclause (2)(b) or (c), Transport for NSW may require the applicant to provide supporting documentation from a medical practitioner.

111 Purposes for which photographs may be kept and used

- (1) A photograph of a person taken under this Division may be kept and used by Transport for NSW only for one or more of the following purposes—
 - (a) to reproduce the likeness of the person on a scheme authority,
 - (b) to assist in determining the identity of the person in connection with an application for a new scheme authority,
 - (c) investigating the commission of, or conducting criminal proceedings for, an offence concerning parking or a scheme authority,
 - (d) a purpose for which a photograph to which the Act, Part 3.5 applies may be kept and used by Transport for NSW under the Part,
 - (e) a purpose for which a photograph to which the *Photo Card Act 2005*, Part 4 applies may be kept and used by Transport for NSW under the Part.
- (2) A photograph may be used for the purpose—
 - (a) at the time the photograph is provided or taken, or
 - (b) at a later time.

112 Release of photographs prohibited

- (1) Transport for NSW must ensure a photograph taken under this Division is not released except—
 - (a) to the NSW Police Force, or
 - (b) to an authority of another jurisdiction or a foreign country having responsibility for issuing interstate or overseas authorities or for the enforcement of parking offences, or
 - (c) for the purpose of conducting criminal proceedings for an offence concerning parking or a scheme authority, or
 - (d) to the Sheriff, for the purpose of fine recovery proceedings, or
 - (e) for a purpose for which a photograph to which the Act, Part 3.5 applies may be released by Transport for NSW under the Part, or

Note. A photograph to which the Act, Part 3.5 applies may be released—

 - (a) for a purpose specified in the Act, section 57(1), or
 - (b) for a purpose specified in the *Road Transport (Driver Licensing) Regulation 2017*, clause 109.
 - (f) as provided under another law, or
 - (g) to the person whose likeness is shown in the photograph or on the database.
- (2) A release authorised by subclause (1)(a)–(e) must be in accordance with a protocol approved by the Privacy Commissioner.

Division 6 Use of scheme authorities

113 Conditions of scheme authorities

- (1) The following conditions are the conditions of use of a scheme authority—
 - (a) the authority must only be used—
 - (i) if the holder of the authority is an individual—in connection with the conveyance of the holder of the authority, or
 - (ii) if the holder of the authority is an organisation—in connection with the conveyance of disabled persons by or on behalf of the organisation,
 - (b) the authority must not be used if—

- (i) it has been defaced or otherwise altered, or
 - (ii) the personal or organisational details on the scheme authority are illegible,
- (c) the whole of the side of the scheme authority marked “THIS SIDE UP” must be clearly displayed—
 - (i) at the left of the vehicle’s windscreen, or on a window on the left hand or passenger side of the vehicle, or
 - (ii) if a location referred to in subparagraph (i) is not practicable—on another part of the windscreen or other window of the vehicle.
- (2) Transport for NSW may also impose other conditions on the use of a scheme authority.
- (3) A condition imposed by Transport for NSW does not have effect until written notice of the condition is given to the holder of the scheme authority.

114 Improper use of scheme authorities

- (1) A person in charge of a vehicle must not display a scheme authority in or on the vehicle in contravention of a condition of the scheme authority.
- (2) The holder of a scheme authority must not permit another person to have possession of, or access to, the scheme authority if the holder suspects, or should reasonably suspect, the other person will use the scheme authority in contravention of a condition of the scheme authority.
Maximum penalty—20 penalty units.

115 Reproducing, copying, defacing, altering or destroying scheme authorities

A person must not, without the permission of Transport for NSW, reproduce, copy, deface, alter or destroy a scheme authority.
Maximum penalty—20 penalty units.

116 Return of scheme authorities

An individual who holds a scheme authority and who ceases to be a disabled person during the currency of the authority must, as soon as is reasonably practicable after ceasing to be a disabled person, return the scheme authority to Transport for NSW.
Maximum penalty—20 penalty units.

117 Production and confiscation of scheme authorities

- (1) An authorised officer may direct the person in charge of a vehicle to remove a scheme authority, or an interstate or overseas authority, or a document or other thing purporting to be an authority, displayed in the vehicle and give it to the officer if—
 - (a) the vehicle is stopped in a parking area for people with disabilities, or
 - (b) the vehicle is parked contrary to a permissive parking sign.
- (2) A person to whom a direction is given must immediately comply with the direction.
Maximum penalty—20 penalty units.
- (3) An authorised officer to whom a scheme authority is given may do one or more of the following—
 - (a) inspect the authority,
 - (b) request and inspect the identification of the person in charge of the vehicle for the purpose of confirming the person’s identity,

- (c) confiscate the scheme authority if the authorised officer has reasonable grounds to suspect the authority—
 - (i) is not being used by the holder of the scheme authority, or
 - (ii) is being used contrary to the conditions of the scheme authority, or
 - (iii) has expired.
- (4) If a scheme authority is confiscated under this clause, Transport for NSW must determine whether to revoke the scheme authority in accordance with clause 119.
- (5) Transport for NSW must return the scheme authority to its holder as soon as is reasonably practicable if it determines not to revoke the authority.
- (6) In this clause—

authorised officer means—

 - (a) a police officer, or
 - (b) an authorised officer within the meaning of clause 132 who is not an officer referred to in Schedule 4 as a Class 3 officer or a Class 4 officer.

parking area for people with disabilities has the same meaning as in the *Road Rules 2014*, rule 203.

Division 7 Expiry and revocation of scheme authorities

118 Expiry of scheme authorities

- (1) A scheme authority expires at the end of the day specified on the scheme authority as the expiry date for the authority.
- (2) Transport for NSW may, by written notice given to the holder of an expired scheme authority, require the holder to return the authority to Transport for NSW.

Note. The Act, section 276 makes provision for how notices to individuals and corporations under this Regulation may be given or served by Transport for NSW. Clause 158 makes provision for how notices to unincorporated associations for the purposes of this Part may be given or served by Transport for NSW.
- (3) If the notice is given to an individual or an organisation, the individual or organisation must immediately return the scheme authority to Transport for NSW as soon as is reasonably practicable after receiving the notice.

Maximum penalty—20 penalty units.
- (4) If the notice is given to an unincorporated association, the person in possession of the scheme authority must immediately return it to Transport for NSW as soon as is reasonably practicable after becoming aware the notice has been given.

Maximum penalty—20 penalty units.

119 Revocation of scheme authorities

- (1) Transport for NSW may, at any time, revoke a scheme authority—
 - (a) for a failure to comply with the conditions of the scheme authority, or
 - (b) for the misuse of the scheme authority, or
 - (c) for a failure by the holder of the scheme authority to comply with a requirement of Transport for NSW under clause 106 or 107, or
 - (d) for any other reason.
- (2) If Transport for NSW decides to revoke a scheme authority, Transport for NSW must give the holder of the scheme authority written notice of—
 - (a) the reasons for the proposed revocation, and

- (b) the action, if any, that must be taken by the holder of the scheme authority to avoid or reverse the revocation, and
- (c) the right of the holder to appeal to the Local Court against the decision to revoke the scheme authority, and
 - Note.** See the Act, Part 7.8 and clause 142 in relation to appeals to the Local Court against revocations of scheme authorities.
- (d) the date after service of the notice on which the revocation takes effect.
 - Note.** The Act, section 276 makes provision for how notices to individuals and corporations under this Regulation may be given or served by Transport for NSW. Clause 158 makes provision for how notices to unincorporated associations for the purposes of this Division may be given or served by Transport for NSW.
- (3) The notice must also state the holder of the scheme authority will no longer be authorised to use the scheme authority on its revocation.
- (4) If the notice is given to an individual or an organisation, the individual or organisation must immediately return the scheme authority to Transport for NSW as soon as is reasonably practicable after receiving the notice.

Maximum penalty—20 penalty units.
- (5) If the notice is given to an unincorporated association, the person in possession of the scheme authority must immediately return it to Transport for NSW as soon as is reasonably practicable after becoming aware the notice has been given.

Maximum penalty—20 penalty units.
- (6) Transport for NSW may decide to revoke a scheme authority without the holder of the scheme authority having been provided with an opportunity to show cause why the scheme authority should not be revoked.
- (7) A scheme authority is revoked in accordance with the terms of the notice unless Transport for NSW, by further written notice to the holder of the scheme authority, withdraws the notice.

Part 8 Other parking schemes—parking permits, controlled loading zones and special event parking schemes

Division 1 Parking permits

120 Parking permits

- (1) A parking authority may issue a permit authorising the parking of a vehicle without charge or time restrictions in a parking space—
 - (a) located within a parking area or road specified in the permit, and
 - (b) designated by the parking authority for use by holders of the permit.
- (2) The permit may be issued in electronic or printed form.
- (3) Transport for NSW may issue TfNSW guidelines from time to time for the issuing of parking permits.
- (4) Transport for NSW must publish the TfNSW guidelines—
 - (a) on a publicly accessible website maintained by Transport for NSW, or
 - (b) if the website referred to in paragraph (a) is not available—on a publicly accessible government website.
- (5) A parking authority must not issue a permit except in accordance with the TfNSW guidelines.
- (6) In this clause—

parking area means the following—

 - (a) pay parking area,
 - (b) permissive parking area,
 - (c) special event parking area.

parking bay has the same meaning as in the *Road Rules 2014*.

parking space means the following—

 - (a) pay parking space,
 - (b) permissive parking space.

permissive parking area means the part of a road to which a permissive parking sign applies.

permissive parking space means a parking bay in a permissive parking area.

Division 2 Controlled loading zone schemes

121 Controlled loading zone schemes

- (1) A parking authority may establish and operate a controlled loading zone scheme for a road within its area of operations by setting aside the whole, or a part, of the road as a controlled loading zone.
- (2) A controlled loading zone must be established in accordance with TfNSW guidelines.
- (3) Use of a controlled loading zone is to be free of charge.
- (4) A parking authority—
 - (a) may, in accordance with TfNSW guidelines, install or otherwise provide loading zone devices for use in connection with a controlled loading zone scheme (**loading zone devices**), and

- (b) may, in accordance with TfNSW guidelines, issue tickets (*loading zone tickets*) for the use of the scheme by a loading zone device.

122 Form and duration of loading zone ticket

- (1) A parking authority may issue a loading zone ticket in a printed or electronic form.
- (2) A loading zone ticket expires at the earlier of the following—
 - (a) the time specified on the ticket by the parking authority,
 - (b) 30 minutes after the time of its issue.

123 Evidence of lawful use of controlled loading zone

- (1) A person must not, in relation to a goods vehicle parked in a controlled loading zone, falsely represent the vehicle is parked lawfully in the zone.
Maximum penalty—20 penalty units.
- (2) For the purposes of this clause, ways in which a false representation is made include, but are not limited to, displaying in or on the vehicle—
 - (a) an article or thing falsely suggesting the goods vehicle is parked lawfully in the zone, or
 - (b) evidence of the lawful use of the controlled loading zone that is altered, defaced, mutilated or illegible.

124 Damage to and misuse of controlled loading zone device

A person must not—

- (a) damage a loading zone device, or
- (b) deface a loading zone device, or
- (c) affix anything, including advertising matter, to a loading zone device, or
- (d) do anything interfering with, or is likely to interfere with, the proper working of a loading zone device unless lawfully authorised to do so, or
- (e) intentionally cause a loading zone device to produce more than one ticket on any one occasion, except for the purpose of obtaining a ticket that is not mutilated or illegible.

Maximum penalty—20 penalty units.

125 Temporary closure of controlled loading zone

- (1) A parking authority may, if it decides the use of a controlled loading zone should be temporarily discontinued, close the zone.
- (2) A controlled loading zone is closed for the purposes of subclause (1) if a sign displaying words to the effect the zone is temporarily closed is erected in, or in close proximity to, the zone.

126 TfNSW guidelines

- (1) Transport for NSW may establish guidelines for the purposes of this Division.
- (2) Transport for NSW must publish the TfNSW guidelines—
 - (a) on a publicly accessible website maintained by Transport for NSW, or
 - (b) if the website referred to in paragraph (a) is not available—on a publicly accessible government website.

- (3) To the extent a provision of this Regulation requires a parking authority to comply with the TfNSW guidelines, a parking authority is not entitled to operate a controlled loading zone if it fails to comply with the guidelines.
- (4) For the purposes of this clause, a parking authority is taken to have complied with a TfNSW guideline until the contrary is proved.

Division 3 Special event parking schemes

127 Special event parking schemes

- (1) Transport for NSW may establish and operate a special event parking scheme for a road.
- (2) For the purposes of a special event parking scheme, Transport for NSW may set aside the whole, or a part of, a road as a special event parking area.

Note. The *Road Rules 2014*, rule 205A–1 makes provision for parking in special event parking areas. The Dictionary in Schedule 8 defines a **special event parking area** to have the same meaning as in the rule.

Part 9 Compliance and enforcement

Division 1 Criminal responsibility

128 Determination of criminal responsibility

(1) **Application of Commonwealth Criminal Code**

Subject to this clause, the *Criminal Code*, Chapter 2, set out in the Schedule to the Commonwealth Criminal Code applies to an offence against this Regulation as if the Chapter were in force as a law of New South Wales.

Note— The Commonwealth Criminal Code, Chapter 2, codifies the general principles of criminal responsibility.

(2) **Offences are strict liability offences**

An offence against this Regulation is a strict liability offence for the purposes of the Commonwealth Criminal Code, Chapter 2, except where this Regulation expressly provides otherwise.

(3) **General defence of accident or reasonable effort**

Without limiting any defence under the Commonwealth Criminal Code, Chapter 2, a person is not liable to a penalty for an offence against this Regulation if the person proves to the satisfaction of the court dealing with the case that the offence—

- (a) was the result of an accident, or
- (b) could not have been avoided by the person's reasonable efforts.

(4) In this clause—

Commonwealth Criminal Code means the *Criminal Code Act 1995* of the Commonwealth.

129 Operation of Crimes (Sentencing Procedure) Act 1999 not affected

This Regulation does not affect the application of the *Crimes (Sentencing Procedure) Act 1999* in relation to this Regulation.

Example— The *Crimes (Sentencing Procedure) Act 1999*, Part 2, Divisions 4 and 5, contain provisions relating to how offence provisions are to be interpreted. For instance, section 17 of that Act defines the amount of a penalty unit. Similarly, section 18 of that Act sets out rules for interpreting provisions in legislation imposing penalties.

130 No double jeopardy for offence against this Regulation and the Road Rules 2014

If an act or omission constitutes an offence against this Regulation and the *Road Rules 2014*, the offender is not liable to be punished twice in relation to the same act or omission.

131 Prescribed ground of exculpation in relation to average speed detection—the Act, s 129(2)

(1) It is a prescribed ground of exculpation for a driver of a heavy vehicle (the *driver concerned*) involved in a speeding offence if—

- (a) a different driver of the heavy vehicle—
 - (i) has been convicted, or found guilty, of the speeding offence, or
 - (ii) has paid the whole, or a part, of the penalty specified in a penalty notice issued to the different driver in relation to the speeding offence, or
 - (iii) has not paid the penalty specified in a penalty notice issued to the different driver for the speeding offence, has not elected to have the matter dealt with by a court and the time for the different driver to have the matter so dealt with has lapsed, and

- (b) the driver concerned gives the Commissioner of Fines Administration a statutory declaration made by the driver concerned stating they obeyed all of the speed limits that applied to them while they were the driver of the vehicle.
- (2) A reference to speed limits in subclause (1)(b) does not include an average speed limit calculated in accordance with the Act, Part 5.3, Division 3.

Division 2 Penalty notice offences

132 Definitions

- (1) In this Division and Schedule 5—
 - authorised officer** means an officer of a class referred to in Schedule 4, being a person who satisfies the criteria specified in the Schedule for an officer of the class.
 - average speed detection zone** means a length of road to which an average speed detection zone sign applies, being a length of road—
 - (a) beginning at an average speed detection zone sign, and
 - (b) ending 300 metres along the length of road in the direction driven by a driver on the road who faces the sign before passing it.
 - average speed detection zone sign** means a traffic sign bearing the words “AVERAGE SPEED”.
 - class A motor vehicle** means—
 - (a) a motor vehicle with a GVM not exceeding 4.5 tonnes, or
 - (b) a motor vehicle and trailer combination with a GCM not exceeding 4.5 tonnes.
 - class B motor vehicle** means—
 - (a) a motor vehicle with a GVM exceeding 4.5 tonnes but not exceeding 12 tonnes, or
 - (b) a motor vehicle and trailer combination with a GCM exceeding 4.5 tonnes but not exceeding 12 tonnes.
 - class C motor vehicle** means—
 - (a) a motor vehicle with a GVM exceeding 12 tonnes, or
 - (b) a motor vehicle and trailer combination with a GCM exceeding 12 tonnes.
 - Safe-T-Cam sign** means a traffic sign bearing the words “SAFE-T-CAM MANAGING SPEED AND FATIGUE”.
 - Safe-T-Cam zone** means a length of road to which a Safe-T-Cam sign applies, being a length of road—
 - (a) beginning at a Safe-T-Cam sign, and
 - (b) ending 300 metres along the length of road in the direction driven by a driver on the road who faces the sign before passing it.
- (2) The persons referred to in Schedule 4 are prescribed as authorised officers for the purposes the Act, section 4(1), definition of **authorised officer**, paragraph (c), but only in relation to the functions conferred on authorised officers by the Act, section 195.
- (3) Words and expressions used in Schedule 4 in connection with a provision of an Act or instrument have the same meanings in the Schedule as they have in the provision.

133 Penalty notice offences

- (1) For the purposes of the Act, section 195, the provisions of this clause have effect.

- (2) An offence specified in Schedule 5, Column 1 is an offence for which a penalty notice may be issued.
- (3) If a reference to a provision in Schedule 5, Column 1 is qualified by words restricting its operation to specified kinds of offences or to offences committed in specified circumstances, a penalty notice may only be issued for the offence if it is an offence of a specified kind or is committed in specified circumstances.
- (4) An authorised officer may issue a penalty notice for the offence only if the authorised officer is—
 - (a) a police officer, or
 - (b) of a class specified for the offence in Schedule 5, Column 2.
- (5) An authorised officer who is an officer or employee of—
 - (a) a council may exercise the functions of an authorised officer only within the local government area of the council, and
 - (b) a declared organisation may exercise the functions of an authorised officer only within the area of operations of the organisation.
- (6) Despite subclause (5), under an arrangement entered into between the bodies concerned for the exercise of the functions of an authorised officer in the areas specified in the arrangement, an authorised officer who is an officer or employee of—
 - (a) a council may exercise the functions of an authorised officer in the local government area of another council, or
 - (b) a declared organisation may exercise the functions of an authorised officer in the area of operations of another declared organisation.
- (7) The amount payable under a penalty notice is the amount specified in relation to the offence in Schedule 5, Column 3.
Note— See also clauses 135 and 136.

134 Penalty levels

For the purposes of this Regulation, penalty amounts are expressed in terms of the following levels—

Level 1 means a penalty of \$78.

Level 2 means a penalty of \$116.

Level 2A means a penalty of \$123.

Level 3 means a penalty of \$194.

Level 3A means a penalty of \$203.

Level 4 means a penalty of \$272.

Level 4A means a penalty of \$285.

Level 5 means a penalty of \$349.

Level 5A means a penalty of \$365.

Level 6 means a penalty of \$464.

Level 6A means a penalty of \$489.

Level 7 means a penalty of \$581.

Level 7A means a penalty of \$609.

Level 8 means a penalty of \$697.

Level 8A means a penalty of \$732.

Level 9 means a penalty of \$890.

- Level 9A* means a penalty of \$935.
Level 10 means a penalty of \$1,123.
Level 10A means a penalty of \$1,179.
Level 11 means a penalty of \$1,393.
Level 11A means a penalty of \$1,464.
Level 12 means a penalty of \$1,472.
Level 12A means a penalty of \$1,545.
Level 13 means a penalty of \$1,819.
Level 14 means a penalty of \$2,400.
Level 14A means a penalty of \$2,520.
Level 15 means a penalty of \$2,557.
Level 15A means a penalty of \$2,676.
Level 16 means a penalty of \$3,639.
Level 16A means a penalty of \$3,821.
Level 17 means a penalty of \$3,947.
Level 17A means a penalty of \$3,955.

Note—“A” numbers are used in relation to motor vehicle speeding offences under the *Road Rules 2014*, rule 20.

135 Penalty levels for certain camera recorded offences

- (1) This clause applies to a camera recorded offence of a kind referred to in the Act, section 184(2) of which a corporation is taken to be guilty under the Act, section 184(1).
- (2) Despite clause 133(7), the amount of the prescribed penalty for the camera recorded offence is—
 - (a) 5 times the amount specified in Schedule 5 as the penalty amount for the offence, or
 - (b) if a lesser amount is specified in the Schedule for the offence when it is committed by a corporation—the specified amount.

136 Lower penalty levels for certain parking offences dealt with by penalty notice

- (1) Despite clause 133(7), the amount payable under a penalty notice for a relevant parking offence is \$83 if the penalty notice is issued by—
 - (a) an authorised officer who is a police officer, or
 - (b) an authorised officer who is of a class specified in relation to the offence in Schedule 5, Column 2, excluding a Class 10 officer or a university parking officer, or
 - (c) a Class 10 officer appointed by a council listed in Schedule 6, Part 1, or
 - (d) a Class 10 officer exercising functions in the local government area of a council listed in Schedule 6, Part 1 in accordance with an arrangement referred to in clause 133(6), or
 - (e) in relation only to a relevant parking offence that is also a designated university parking offence—a university parking officer for a university listed in Schedule 6, Part 2.
- (2) The Minister must not recommend the making of a regulation amending Schedule 6 to include the name of a council or a university unless the Treasurer has advised the Minister the council or university concerned has notified the Treasurer in writing it has resolved to opt in to the lower penalty prescribed by this clause.

(3) In this clause—

designated university parking offence means an offence created by the *Road Rules 2014*, rule 168–1, 179–1 or 207.

relevant parking offence means an offence created by the following provisions—

- (a) the *Local Government Act 1993*, section 650(1), in relation to a notice or sign referred to in that Act, section 650(2)(a) or (b),
- (b) the *Local Government Act 1993*, section 650(4) or (5),
- (c) the *Local Government Act 1993*, section 650A(1), in relation to a notice or sign referred to in that Act, section 650A(2)(a) or (b),
- (d) the *Local Government Act 1993*, section 650A(4) or (5),
- (e) the *Road Rules 2014*, rule 168–1, 179–1, 205, 207, 210 or 211,
- (f) the *Road Rules 2014*, rule 184(1), other than in relation to a minibus zone in a clearway, transit lane or bus lane.

university parking officer, for a university, means a person—

- (a) who is employed by the university as an enforcement officer, or
- (b) who is subject to the control and direction of the university as an enforcement officer.

137 Grace period for certain parking offences

(1) A penalty notice must not be issued for an offence under the *Road Rules 2014*, rule 207, allegedly committed during the grace period for the offence if—

- (a) the vehicle is parked in a location where parking is permitted if a fee is paid, and
- (b) a fee has been paid for the hour immediately before the grace period commenced entitling the vehicle to be parked in the location, and
- (c) evidence of the payment of the fee is displayed in or on the vehicle, and
- (d) the offence did not occur in a shared zone within the meaning of the *Road Rules 2014*.

(2) This clause does not prevent the issue of a penalty notice for an offence under the *Road Rules 2014*, rule 154, 156, 167, 176, 179, 183, 186 or 205A–1, if, during the grace period for a designated parking offence—

- (a) a prescribed parking control sign applies to the same length of road or area as that in which the relevant vehicle is parked, and
- (b) the relevant driver is prohibited by one or more of those rules from parking on the length of road, or in the area, during the grace period.

(3) In this clause—

designated parking offence means an offence under the *Road Rules 2014*, rule 207.

grace period for an offence under the *Road Rules 2014*, rule 207, means the 15 minutes following the expiry of the time a driver may allow the driver's vehicle to remain parked without committing the offence.

prescribed parking control sign means the following—

- (a) a bicycle lane sign as referred to in the *Road Rules 2014*, rule 153,
- (b) a bus lane sign as referred to in the *Road Rules 2014*, rule 154,
- (c) a transit lane sign as referred to in the *Road Rules 2014*, rule 156,
- (d) a no stopping sign as referred to in the *Road Rules 2014*, rule 167,
- (e) a clearway sign as referred to in the *Road Rules 2014*, rule 176,

- (f) a loading zone sign as referred to in the *Road Rules 2014*, rule 179,
- (g) a bus zone sign as referred to in the *Road Rules 2014*, rule 183,
- (h) a mail zone sign as referred to in the *Road Rules 2014*, rule 186,
- (i) a special event parking area sign as referred to in the *Road Rules 2014*, rule 205A-1.

138 Offence—unlawful destruction of penalty notices

A person must not, without lawful excuse, remove or deface, destroy or otherwise damage a penalty notice left on or attached to a motor vehicle or trailer under the Act, Part 7.3, Division 3.

Maximum penalty—20 penalty units.

Part 10 Appeals

Division 1 Preliminary

139 Definition

In this Part—

examiner's authority and *proprietor's authority* have the same meanings as in the *Road Transport (Vehicle Registration) Regulation 2017*.

Division 2 Appealable decisions

140 Driver licensing decisions

The following classes of decisions of Transport for NSW made under the *Road Transport (Driver Licensing) Regulation 2017* are prescribed for the purposes of the Act, section 266(1), definition of *appealable decision*, paragraph (1)—

- (a) a decision not to take into account, under the Regulation, clause 52(3), some or all of the period that a person has held a licence to drive a motor vehicle in another jurisdiction or another country,
- (b) a decision to vary a person's driver licence under the Regulation, clause 57, 65 or 66,
- (c) a decision to suspend or cancel a person's driver licence under the Regulation, clause 24, 30, 65 or 66,
- (d) a decision, based on an opinion formed by Transport for NSW under the Regulation, clause 96(4)(g), (h), (i) or (o), a person has ceased to be exempt from the requirements of the driver licensing law,
- (e) a decision to revoke an approval, within the meaning of the Regulation, Part 11 (Interlock driver licences and devices), of a person.

141 Vehicle registration decisions

- (1) The following classes of decisions of Transport for NSW made under the *Road Transport (Vehicle Registration) Regulation 2017* are prescribed for the purposes of the Act, section 266(1), definition of *appealable decision*, paragraph (1)—
 - (a) a decision, notified to a person under the Regulation, clause 74 to—
 - (i) refuse to issue an examiner's authority or a proprietor's authority to a person, or
 - (ii) to cancel an examiner's authority or a proprietor's authority, or
 - (iii) to suspend an examiner's authority or a proprietor's authority, or
 - (b) a decision to suspend the operation of Schedule 1, clause 9 or 11 of the Regulation in relation to a registrable vehicle,
 - (c) the following decisions under the Regulation, Part 6—
 - (i) a decision to cancel a compliance certificate,
 - (ii) a decision to refuse an application for a certifier's licence or for the renewal or variation of a certifier's licence, excluding a decision made on the ground that Transport for NSW is of the opinion that the person is not a fit and proper person to hold the licence,
 - (iii) a decision to cancel or suspend a certifier's licence or vary a certifier's licence or the term of a certifier's licence, excluding a decision to impose or vary a condition on all certifier's licences or a decision under the Regulation, clause 92 to immediately suspend a certifier's licence.

- (2) A decision referred to in subclause (1)(a)(iii) is not prescribed if Transport for NSW is not required to comply with the *Road Transport (Vehicle Registration) Regulation 2017*, clause 72(3), in relation to the decision.

Note— The *Road Transport (Vehicle Registration) Regulation 2017*, clause 72(4) does not require compliance with clause 72(3) of the Regulation if Transport for NSW has reason to suspect the holder of an authority intentionally or recklessly contravened certain rules and is likely to commit further contraventions of those rules.

142 Mobility parking scheme decisions

A decision of Transport for NSW to revoke a person's mobility parking scheme authority of a person is prescribed for the purposes of the Act, section 266(1), definition of ***appealable decision***, paragraph (1).

143 Exclusion from definition of “appealable decision”

For the purposes of the Act, section 266(3)(b), the following classes of decisions are excluded from the definition of ***appealable decision*** in the section—

- (a) a decision of Transport for NSW to suspend a person's driver licence under the Act, section 43A(7),
- (b) a decision of Transport for NSW to cancel the registration of a registrable vehicle on the ground that is required to do so by the Act, section 84 or 104C,
- (c) a decision of Transport for NSW made on the basis of the ground referred to in the *Road Transport (Driver Licensing) Regulation 2017*, clause 56(2)(d) or (e),
- (d) a decision of Transport for NSW to cancel a person's interlock driver licence under the *Road Transport (Driver Licensing) Regulation 2017*,
- (e) a decision of Transport for NSW to require a person to return a number-plate to Transport for NSW under the *Road Transport (Vehicle Registration) Regulation 2017*, clause 32,
- (f) a decision of Transport for NSW to cancel the registration of a vehicle under the *Road Transport (Vehicle Registration) Regulation 2017*, clause 45(1A).

Division 3 Notification of appeal rights and giving of reasons concerning driver licensing decisions

144 Preliminary

- (1) This Division applies to an affected driver who is eligible to appeal to the Local Court under the Act, Part 7.8, against a relevant decision.
- (2) In this Division—
- affected driver*** means the following—
- (a) an applicant for a driver licence,
 - (b) the holder of an Australian driver licence,
 - (c) the holder of a foreign driver licence within the meaning of the Act, Part 5.1.
- licensing decision*** means a decision of Transport for NSW made under the driver licensing law.

145 Notification of appeal rights in relation to certain driver licensing decisions

Transport for NSW must notify an affected driver of the driver's right to appeal a licensing decision at the time Transport for NSW notifies the driver of the decision.

146 Application for reasons for decision

- (1) An affected driver may apply to Transport for NSW for written reasons for the licensing decision.
- (2) Within 14 days after receiving the application, Transport for NSW must provide to the applicant—
 - (a) a written statement of the decision and written reasons for the decision, and
 - (b) information as to the identity or position in Transport for NSW of the person who made the decision.
- (3) An application may be made before or during the period in which an affected driver may lodge a notice of appeal under the Act, section 267.
- (4) An affected driver cannot make an application if Transport for NSW has already provided the person with the details referred to in subclause (2).

Division 4 Stays and adjournments

147 Certain decisions stayed pending appeal

- (1) In this clause, a *relevant decision* means—
 - (a) a decision of Transport for NSW to suspend, vary or cancel a driver licence under the Act on any ground other than medical unfitness or incompetence to drive a motor vehicle,
 - (b) a decision of Transport for NSW that an exemption under the Act from a requirement to hold a driver licence no longer applies to a person,
 - (c) a decision of Transport for NSW of the kind referred to in clause 141(1)(c),
 - (d) a decision of Transport for NSW to suspend or cancel an examiner's authority or proprietor's authority,
 - (e) a decision of Transport for NSW to suspend the registration of a motor vehicle under the *Road Transport (Vehicle Registration) Regulation 2017*, clause 45(2), (3) or (4).
- (2) However, a decision referred to in subclause (1)(a) or (b) is not a relevant decision if it is a decision of the kind referred to in clause 148.
- (3) If a person appeals to the Local Court against a relevant decision, the decision—
 - (a) has effect—
 - (i) only if the Local Court hearing the appeal confirms the decision, or the appeal is withdrawn, and
 - (ii) subject to a variation of a decision by the Local Court, and
 - (b) takes effect on and from—
 - (i) the date on which the Local Court confirms the decision, or
 - (ii) a later date the Local Court may order, or
 - (iii) if the appeal is withdrawn—the date on which it is withdrawn.

148 Certain decisions stayed only in exceptional circumstances

- (1) The Local Court may, in an appeal against a decision of a police officer to give a person an immediate licence suspension notice, make an order staying the decision.
- (2) The Local Court may, in an appeal against the following decisions of Transport for NSW, make an order staying the decision—
 - (a) a decision to suspend the registration of a heavy vehicle under the *Road Transport (Vehicle Registration) Regulation 2017*, clause 46, or

- (b) a decision to vary, suspend or cancel the driver licence of a driver of a heavy vehicle under the *Road Transport (Driver Licensing) Regulation 2017*, clause 66, or
 - (c) a decision of Transport for NSW, based on an opinion formed by Transport for NSW under the *Road Transport (Driver Licensing) Regulation 2017*, clause 96(4)(i), a driver of a heavy vehicle has ceased to be exempt from the requirements of the driver licensing law.
- (3) The order to stay the decision may only be made—
 - (a) for an appeal under subclause (1)—in exceptional circumstances, or
 - (b) for an appeal under subclause (2)—in exceptional circumstances and after the Court considers the circumstances of aggravation, if any.
- (4) In determining if there are ***exceptional circumstances***, the Local Court is to take into account each of the following—
 - (a) the strength of the prosecution evidence,
 - (b) the affected person’s need for a licence,
 - (c) in relation to an appeal against a decision of a police officer to give the person an immediate licence suspension notice—the potential danger to the community if an order is made,
 - (d) in relation to an appeal against a decision of Transport for NSW to suspend the registration of a heavy vehicle—the hardship likely to be experienced by the registered operator of the vehicle,
 - (e) any other matter the Local Court considers to be relevant.
- (5) In determining if there are ***circumstances of aggravation***, the Local Court is to take account of whether the relevant heavy vehicle—
 - (a) caused damage to road infrastructure, or
 - (b) was involved in an accident, or
 - (c) caused a danger or obstruction to traffic, or
 - (d) caused an adverse effect on public amenity.

149 Adjournment of certain proceedings

- (1) The Local Court may adjourn appeal proceedings concerning a decision of Transport for NSW about a licence if it appears to the Court that—
 - (a) the licence is affected by another decision of Transport for NSW as well as the one under appeal in the proceedings, and
 - (b) the appellant has commenced or intends to commence appeal proceedings under the Act in relation to the other decision.
- (2) The Court may adjourn an appeal concerning a decision of a police officer to issue a suspension notice under the Act, section 224 if it appears to the Court that—
 - (a) the licence of the appellant is affected by a decision of Transport for NSW as well, and
 - (b) the appellant has commenced or intends to commence appeal proceedings under the Act in relation to Transport for NSW’s decision.
- (3) An adjournment may be ordered—
 - (a) pending hearing of the other appeal, or
 - (b) so both appeals may be heard together.

Division 5 Determination of certain appeals

150 Appeals against suspension of registration

- (1) The Local Court may, in determining an appeal against the suspension of registration of a motor vehicle under the Act, section 243, take into account whether or not the registered operator of the motor vehicle—
 - (a) knew, or could reasonably be expected to have known, the motor vehicle had been used or was likely to be used in connection with a sanctionable offence, or
 - (b) had consented to the use of the vehicle, or had taken all reasonable steps to prevent a person using the vehicle without consent.
- (2) In this clause—
sanctionable offence has the same meaning as in the Act, Part 7.6.

151 Document that may be used in examiner's and proprietor's authorities appeals

- (1) This clause applies to a report on a decision of a class referred to in clause 141(1)(a)—
 - (a) provided by a committee of review to Transport for NSW under the *Road Transport (Vehicle Registration) Regulation 2017*, clause 73, and
 - (b) certified by Transport for NSW as having been provided by the committee.
- (2) A report is to be admitted as evidence of the contents of the report in proceedings before the Local Court for an appeal against the decision the subject of the report.

152 Determination of driver licence suspension appeals involving death or grievous bodily harm

- (1) The Local Court may allow an appeal against a decision to suspend a person's driver licence under the *Road Transport (Driver Licensing) Regulation 2017* on the grounds referred to in the Regulation, clause 65(2), only if the Court is satisfied—
 - (a) there is nothing in the person's medical condition to suggest the person is, or will again become, incapable of controlling a motor vehicle, and
 - (b) the incident leading to the suspension of the licence—
 - (i) was caused by something other than the person's medical condition at the time, or
 - (ii) was caused by the person's medical condition at the time, being a condition to which the person is no longer subject.
- (2) If a person alleges the incident was caused by the person's medical condition at the time, the fact the person has been acquitted of an offence arising out of the incident is irrelevant to the Local Court's consideration of the matters referred to in subclause (1)(b).

Part 11 Miscellaneous

Division 1 Special service requirements

153 Application of Division

- (1) For the purposes of the Act, sections 276(3) and 277(2), the provisions of this Division set out—
 - (a) the only manner in which a notice may be given or served—
 - (i) under the driver licensing law, or
 - (ii) on the registered operator of a registrable vehicle under the vehicle registration law, and
 - (b) the date on which service of a document under the *Road Transport (Driver Licensing) Regulation 2017* or the *Road Transport (Vehicle Registration) Regulation 2017* is taken to have been effected, and
 - (c) additional means of lodging a notice or other document for the purposes of those Regulations with Transport for NSW, and
 - (d) the manner in which a notice may be given or served on an individual or a organisation under this Regulation, Part 7.
- (2) In this Division—

vehicle registration law means—

 - (a) the Act, Chapter 4, and
 - (b) the *Road Transport (Vehicle Registration) Regulation 2017*.

154 Service of notices on persons and delivery of things to TfNSW under driver licensing law

- (1) Transport for NSW may give or serve a notice under the driver licensing law on a person by sending the notice—
 - (a) by post or by some other means to the person's last known home address, or
 - (b) to the address for service of notices recorded in the NSW driver licence register—
 - (i) if the address for service is an electronic address—by electronic communication to the electronic address, or
 - (ii) otherwise—by post or by some other means.
- (2) However, a notice given for the purposes of the *Road Transport (Driver Licensing) Regulation 2017*, clause 69, may only be given personally.
- (3) If a person's home address or address for service of notices is in another jurisdiction, Transport for NSW may request the driver licensing authority of another jurisdiction to act on its behalf in—
 - (a) giving a notice to or serving a notice on the person, or
 - (b) performing another act Transport for NSW could lawfully perform in this jurisdiction.
- (4) If Transport for NSW receives a request under a provision of the corresponding driver law of another jurisdiction corresponding with subclause (3), it may act on behalf of the driver licensing authority of the jurisdiction accordingly.

155 Service of notices on registered operators and delivery of things to TfNSW under vehicle registration law

Transport for NSW may give or serve a notice under the vehicle registration law on the registered operator of a registrable vehicle by sending the notice—

- (a) by post or by some other means to—
 - (i) if the registered operator is an individual—the registered operator’s home address, or
 - (ii) if the registered operator is a corporation—in the manner referred to in the Act, section 276(2), or
- (b) to the address for service of notices recorded in the NSW registrable vehicles register in relation to the vehicle—
 - (i) if the address for service is an electronic address—by electronic communication to the electronic address, or
 - (ii) otherwise—by post or by some other means.

156 Date of effecting service

- (1) The date on which a person is taken to have been given or served with a notice under the *Road Transport (Driver Licensing) Regulation 2017* or the *Road Transport (Vehicle Registration) Regulation 2017* or a notice under the Act, section 54(2), is—
 - (a) if the notice is sent by mail—the fourth working day after the notice was posted, or
 - (b) if the notice is delivered to the person personally—the date on which it is delivered, or
 - (c) if the notice is sent by electronic communication to an electronic address—the date the notice is sent.
- (2) However, a notice sent by electronic communication is not taken to be given or served if Transport for NSW receives an automated reply, by electronic communication, indicating the delivery of the notice to the electronic address has failed.
- (3) If subclause (2) applies, the notice must be served—
 - (a) by post, or
 - (b) for service of a notice under the *Road Transport (Driver Licensing) Regulation 2017* or a notice under the Act, section 54(2)—by some other means, or
 - (c) for service of a notice under the *Road Transport (Vehicle Registration) Regulation 2017*—by some other means in the manner referred to in clause 159(a).

157 Forwarding, surrendering or delivering notification, document or thing to TfNSW

If it is provided in the *Road Transport (Driver Licensing) Regulation 2017* or the *Road Transport (Vehicle Registration) Regulation 2017* a notification, document or thing must be forwarded, surrendered or delivered to Transport for NSW, it is sufficient compliance with the provision in the Regulation if the notification, document or thing is forwarded or surrendered to or delivered at a registry within the time prescribed by the Regulation.

158 Service of documents under Part 7—mobility parking scheme authorities

- (1) For the purposes of the Act, section 276(3)(a), a notice required to be given to or served on an individual or a organisation under Part 7 may be given or served—

- (a) by electronic communication to an electronic address specified by the person or corporation for the service of documents of the kind, and
- (b) if the organisation is an unincorporated association—by sending the notice by post or some other means to the address for service of the association—
 - (i) specified in its application form for a mobility parking scheme authority, or
 - (ii) otherwise notified to Transport for NSW.
- (2) However, a notice sent by electronic communication is not taken to be given or served if Transport for NSW receives an automated reply, by electronic communication, indicating the delivery of the notice to the electronic address has failed.
- (3) If subclause (2) applies, the notice must be given or served—
 - (a) if the notice is for an individual—in the manner referred to in the Act, section 276(1),
 - (b) if the notice is for a corporation—in the manner referred to in the Act, section 276(2),
 - (c) if the notice is for an unincorporated association—in the manner referred to in subclause (1)(b).
- (4) This clause does not affect the operation of another provision of a law or of the rules of a court authorising a document to be given to or served on a person by another method.

Division 2 Operation of inconsistent legislation

159 Royal Botanic Gardens and Domain Trust Act 1980

- (1) For the purposes of the Act, section 14(5), a provision of the *Royal Botanic Gardens and Domain Trust Act 1980* relating to parking on Trust lands prevails over an inconsistent provision of the road transport legislation concerning parking.
- (2) In this clause—
provision of the Royal Botanic Gardens and Domain Trust Act 1980 includes a provision of a regulation made under that Act.
Trust lands has the same meaning as in the *Royal Botanic Gardens and Domain Trust Act 1980*.

160 Local Government Act 1993

- (1) For the purposes of the Act, section 14(5), a provision of the *Local Government Act 1993* relating to the use of skating equipment on public land prevails over an inconsistent provision of the road transport legislation concerning the use of skating equipment.
- (2) In this clause—
provision of the Local Government Act 1993 includes a provision of a regulation made under that Act.
public land has the same meaning as in the *Local Government Act 1993*.

Division 3 Offences and matters relating to offences

161 Offence—failure to comply with order, notice, direction, requirement or request

- (1) A person must not fail, without reasonable excuse, to comply with an order, notice, direction, requirement or request given or made to the person under this Regulation or the *Road Rules 2014*.

Maximum penalty—20 penalty units.

- (2) A person is not liable to be punished for an offence under subclause (1) if the person is liable to be punished for an offence in relation to the same failure to comply under another provision of this Regulation or the *Road Rules 2014*.

Example— The offence in clause 98(2) is an example of an offence to which subclause (2) might apply.

162 Offence—false or misleading information

A person must not, in purported compliance with a provision of this Regulation or the *Road Rules 2014*, provide information the person knows to be false or misleading in a material particular.

Maximum penalty—20 penalty units.

163 Mass requirements on certain roads and bridges

- (1) The council of a local government area or Transport for NSW may do the following things by a notice (a **limit notice**) conspicuously displayed on or adjacent to the road, bridge or road-ferry concerned—

- (a) prohibit vehicles with a laden mass exceeding a specified maximum mass from passing along or over a road, bridge or causeway,
(b) prohibit vehicles with a laden mass exceeding a specified maximum mass from using a road-ferry maintained in connection with a road.

- (2) A limit notice must—

- (a) display the words “BRIDGE LOAD LIMIT” or “ROAD LOAD LIMIT”, or
(b) be in, or similar to, a sign approved by Transport for NSW for the purposes of this clause.

- (3) A limit notice displaying the words “BRIDGE LOAD LIMIT” or “ROAD LOAD LIMIT” prohibits the passage, from a direction facing the notice, of a vehicle or combination if—

- (a) the total mass of the vehicle or combination exceeds the gross mass indicated by the notice, or
(b) the mass carried by an axle or axle group of the vehicle or combination exceeds the mass indicated by the notice for the kind of axle or axle group.

- (4) A limit notice in, or similar to, a sign approved by Transport for NSW for the purposes of this clause prohibits the passage, from a direction facing the notice, of a vehicle or combination exceeding the total mass indicated by the notice.

- (5) The powers conferred by this clause may only be exercised in relation to classified roads by Transport for NSW.

- (6) A person must not fail to comply with the terms of a limit notice.

Maximum penalty—30 penalty units.

- (7) In an emergency, for example a fire, explosion or natural disaster including a drought, Transport for NSW may exempt a vehicle or combination, or its driver or owner, from compliance with a limit notice if—

- (a) the vehicle or combination is being used, or is intended to be used, to protect life or property, to restore communication or the supply of energy, water or services including sewage disposal or to provide drought relief, and
 - (b) the exemption does not present an unreasonable danger to other road users.
- (8) An exemption may be subject to conditions imposed by Transport for NSW.
- (9) Transport for NSW must make a written record of the exemption, and any conditions of the exemption, but may communicate the exemption orally to the owner or driver.
- (10) In this clause—
- (a) **bridge** and **classified road** have the same meanings as in the *Roads Act 1993*, and
 - (b) **laden mass** means the mass of a vehicle and its load borne on the surface on which it is standing or running.
 - (c) **total mass** and **vehicle** have the same meanings as in this Regulation, Part 4.

164 Prescribed speeding offence

For the purposes of the Act, section 4(1), definition of **prescribed speeding offence** and the Act, section 204(4)(a), a speeding offence within the meaning of the *Road Rules 2014*, rule 10–2, is prescribed.

165 Limitation period for certain offences

For the purposes of the Act, section 202(2), the following provisions of the *Road Transport (Vehicle Registration) Regulation 2017* are prescribed as provisions for which proceedings may be commenced not later than 2 years after the date alleged to be the date for an offence on which the offence was committed—

- (a) clause 68(8)–(10),
- (b) clause 69(4) and (6),
- (c) clause 85(5),
- (d) clause 93.

166 Certain provisions not to apply to light rail vehicles

A provision of this Regulation with which a driver of a light rail vehicle could not reasonably comply, having regard to the fixed tracks on which a light rail vehicle travels, the route taken by the tracks and other exigencies of the method of travel, is taken not to apply to the driver.

Division 4 Administrative matters

167 Certificate as to costs incurred in removal of dangers and obstructions to traffic—the Act, s 142

The general manager of a council of a local government area is a prescribed person in relation to the issue of a certificate referred to in the Act, section 142(3).

168 Removal of unattended vehicles

- (1) The following are prescribed for the purposes of the Act, section 143(12), definition of **prescribed place**—
- (a) a bicycle lane,
 - (b) a bus lane,
 - (c) a freeway,

- (d) a T-Way lane,
 - (e) a length of road to which a clearway sign applies as referred to in the *Road Rules 2014*, rule 176,
 - (f) a transit lane.
- (2) For the purposes of the Act, section 143(12), definition of **prescribed tow-away charge**, the prescribed tow-away charge is the charge prescribed in Schedule 1.
- (3) In this clause—
bicycle lane, **bus lane**, **freeway**, **T-Way lane** and **transit lane** have the same meaning as in the *Road Rules 2014*.

169 Number-plate confiscation notices

- (1) The following information is prescribed for the purposes of the Act, section 237(1), definition of **number-plate confiscation notice**—
- (a) a brief description of the effect of the notice, including a statement of the action that may be taken against the registered operator and penalties that may apply if it is not complied with,
 - (b) if a number-plate confiscation notice is issued in relation to a sanctionable offence—the provisions of the Act, regulations or rules imposing the sanctionable offence,
 - (c) the registration number of the motor vehicle to which it relates,
 - (d) the vehicle's VIN or, if there is no VIN, the chassis number and engine number of the vehicle,
 - (e) the date of issue of the notice and the date on which the number-plate confiscation period imposed by the notice will end,
 - (f) the name of the police area command or police district of the police officer who issued the notice,
 - (g) the address of the registry or other place from which the number-plates can be collected on or after the end of the number-plate confiscation period,
 - (h) information about the right to apply to the Local Court to seek release of the number-plates.
- (2) In this clause—
VIN has the same meaning as in the *Road Transport (Vehicle Registration) Regulation 2017*.

170 Fees for information from records of TfNSW

- (1) Transport for NSW may issue information from its records, including a certificate under the Act, section 257, on the payment of the fee prescribed by Schedule 1.
- (2) Transport for NSW may waive the fee if it is satisfied the payment of the fee would result in undue hardship to the person seeking access to information.

171 Delegation of TfNSW's licensing and registration functions

- (1) For the purposes of the Act, section 273(1)(b), the following persons or classes of persons are prescribed in relation to the delegation of the licensing and registration functions of Transport for NSW—
- (a) a statutory corporation, or an officer or employee of a statutory corporation,
 - (b) the holder of a statutory office,
 - (c) a member of staff of the Public Service of New South Wales,

- (d) a local council, or an officer or employee of a local council,
 - (e) any other person who, in the opinion of Transport for NSW, has appropriate qualifications for the exercise of the function to be delegated.
- (2) The **licensing and registration functions** of Transport for NSW are—
- (a) the functions of Transport for NSW under the Act, Chapter 3 and the *Road Transport (Driver Licensing) Regulation 2017*, and
 - (b) the functions of Transport for NSW under the Act, Chapter 4 and the *Road Transport (Vehicle Registration) Regulation 2017*.

172 Savings and repeal of Road Transport (General) Regulation 2013

- (1) The *Road Transport (General) Regulation 2013* is repealed.
- (2) An act, matter or thing, that immediately before the repeal of the *Road Transport (General) Regulation 2013*, had effect under that Regulation continues to have effect under this Regulation.
- (3) Without limiting subclause (2), a person who, immediately before the repeal of the *Road Transport (General) Regulation 2013*, was an authorised officer of a class specified in Column 1 of the following table under that Regulation is taken, on the repeal of that Regulation, to be an authorised officer of a class specified in Column 2 of the table under this Regulation.

Column 1	Column 2
Class 1	Class 1
Class 2	Class 2
Class 3	Class 3
Class 4	Class 2
Class 6	Class 5
Class 7	Class 6
Class 8	Class 7
Class 9	Class 8
Class 10	Class 9
Class 12	Class 10
Class 14	Class 11
Class 15	Class 12
Class 16	Class 13
Class 17	Class 4

173 Repeal of Schedule 7

Schedule 7 is repealed on the day following the day on which this Regulation commences.

public consultation draft

Road Transport (General) Regulation 2021 [NSW]
Schedule 1 Fees and charges

Schedule 1 Fees and charges

Part 1 Fees

Fee category	Provision prescribing fee	Amount payable (\$)
1 Daily storage fee for an impounded motor vehicle under the Act, section 250	clause 44	22
2 Application for a permit under clause 62	clause 62(2)(b)	75
3 Issue of information from records of Transport for NSW, including certificates and other documents issued under the Act, section 257	clause 170	23

Part 2 Charges

Charge category	Provision prescribing fee	Amount payable (\$)
1 Prescribed tow-away charge for removal of unattended motor vehicle under the Act, section 143	clause 168	207

public consultation draft

Road Transport (General) Regulation 2021 [NSW]
Schedule 2 Declared organisations

Schedule 2 Declared organisations

Schedule 8, Dictionary

Column 1	Column 2	Column 3
Declared organisation	Area of operations	Responsible Minister
Centennial Park and Moore Park Trust	<p>Centennial Park—being the part of Woollahra, Waverley, Randwick and Sydney bounded by, but not including, Oxford Street, York Road, Darley Road, Alison Road, Dacey Avenue, South Dowling Street, Flinders Street and Moore Park Road.</p> <p>Moore Park—being the part of Randwick and Sydney south of Dacey Avenue and bounded by, but not including, Dacey Avenue, Anzac Parade and South Dowling Street.</p>	
Charles Sturt University	<p>Albury Wodonga campus, Thurgoona— being Lot 1, DP 11839783; Lot 620, DP 717911 and Lots 31 and 33, DP 1172127.</p> <p>Bathurst campus—being the part of Mitchell bounded by, but not including, Panorama Avenue, Browning Street, Research Station Drive and Bathurst Primary Industries Centre.</p> <p>Dubbo campus—being Lot 902, DP 1033617.</p> <p>Orange campus—being Lots 300 and 301, DP 1047282; Lots 17 and 21, DP 6694; Lots 2–5, DP 7214; Lot 4, DP 524856; Lot 6, DP 524858; Lot 28, DP 1100800; Lot 1, DP 319566 and Lot 1, DP 548053.</p> <p>Port Macquarie campus—being Lots 2 and 3, DP 1178043 and Lots 7 and 8, DP 1094444.</p> <p>Wagga Wagga campus—being the part of the Wagga Wagga City Council area designated by the Geographical Names Board of New South Wales as a suburb called “Charles Sturt University”, excluding public roads.</p> <p>Wagga Wagga south campus—being the part of Turvey Park bounded by, but not including, Fernleigh Road, Hely Avenue, Charleville Road, College Avenue, Urana Street and Idsal Road.</p>	
Hunter and Central Coast Development Corporation	<p>Station Street Zone—being Station Street and the part of Lot 5, DP 1265104 bounded by, but not including, the northern property boundary of Lot 5, DP 1238761, Hannell Street, Honeysuckle Drive and Cottage Creek, excluding public roads.</p> <p>Steel Street Zone—being the part of Lot 1, DP 852552 bounded by the northern, eastern and western boundaries and the marked parking spaces along the southern boundary and the part of Lot 1, DP 1226145 and Lot 2, DP 1037267 bounded by, but not including, the light rail corridor, Hunter Street and Steel Street, excluding public roads.</p>	

public consultation draft

Road Transport (General) Regulation 2021 [NSW]
Schedule 2 Declared organisations

Column 1	Column 2	Column 3
Declared organisation	Area of operations	Responsible Minister
	<p>Wickham Zone—being the part of Lot 5, DP 1265104 and Lot 3, DP 1238761 bounded by, but not including, Hannell Street, Honeysuckle Drive, Cottage Creek and the land along the waterfront containing a boardwalk and zoned as public recreational space, excluding public roads.</p> <p>Wright Lane Zone—being Lots 2, 3, 5 and 6, DP 1247375.</p>	
Hunter New England Local Health District	<p>Rankin Park campus—being Lots 1, 2 and 4, DP 839929 and Lots 131 and 132, DP 1053492.</p> <p>James Fletcher Hospital—being Lot 1, DP 10969317 and Lot 10, DP 1087691.</p> <p>Belmont Hospital—being Lots 12 and 13, DP 848759.</p> <p>Wallsend campus—being Lot 1, DP 330699; Lots 11, 12 and 16, DP 13487 and Lots A, C, D, E and F, DP 312480.</p> <p>Maitland Hospital—being Lots 1 and 3, DP 375615; Lots 1–4, DP 154695; Lots 2 and 6, DP 37290; Lots 380–382, DP 538296; Lot 1, DP 198235; Lot 1, DP 198328; Lots 17 and 18, DP 746311 and part Lot 138, DP 755237 comprising the land in Conveyance Book 4537 No 172.</p> <p>Waratah campus—being Lot 3, DP 852177.</p> <p>Tamworth Base Hospital—being Lots 1, 99 and 335, DP 753848.</p>	
Macquarie University	Marsfield campus—being the part of Marsfield bounded by, but not including, Epping Road, Herring Road, Talavera Road, Culloden Road, Balaclava Road, Vimiera Road, Waterloo Road and Marsfield Park.	
Mid North Coast Local Health District	<p>Coffs Harbour Health Campus—being Lot 202, DP 1127790 and Lot 14, DP 261222.</p> <p>Port Macquarie Base Hospital—being Lot 23, DP 1099567.</p>	
Northern NSW Local Health District	<p>Lismore Base Hospital—being the part of Lismore bounded by, but not including, Fermoy Avenue, Weaver Street, Orion Street, Hunter Street, Uralba Street and Little Uralba Street.</p> <p>Lismore Base Hospital Car Park—being Lot 2, DP 1215351.</p> <p>Lismore Riverlands Campus—being Lot 1, DP 1032149.</p>	
Northern Sydney Local Health District	Royal North Shore Hospital—being Lots 1 and 2, DP 1158469 and Lot 102, DP 1075748.	

public consultation draft

Road Transport (General) Regulation 2021 [NSW]
Schedule 2 Declared organisations

Column 1	Column 2	Column 3
Declared organisation	Area of operations	Responsible Minister
Venues NSW	Trust land within the meaning of the former <i>Parramatta Stadium Trust Act 1988</i> as in force immediately before its repeal, except for lots 951, 958, 959, 960 and 965 in the plan filed in the office of the Registrar-General as Deposited Plan 42643.	
Royal Botanic Gardens and Domain Trust	The Royal Botanic Gardens and The Domain—being those parts of the Trust lands, within the meaning of the <i>Royal Botanic Gardens and Domain Trust Act 1980</i> , described in that Act, Schedule 2, Parts 1 and 2, and including Art Gallery Road, Mrs Macquaries Road and Hospital Road.	
Place Management NSW	<p>The Rocks area of Sydney, comprising the following streets—</p> <ul style="list-style-type: none">(a) Cumberland Street, between Grosvenor Street and George Street,(b) Gloucester Street, between the Cahill Expressway and Cumberland Street,(c) Harrington Street, between Grosvenor Street and Argyle Street,(d) Essex Street, between George Street and Cumberland Street,(e) Argyle Street, between George Street and Cumberland Street,(f) George Street, between Globe Street and Cumberland Street,(g) Hickson Road, between Campbells Cove and Hickson Road Reserve,(h) Globe Street, between George Street and Harrington Street,(i) Atherden Street, between George Street and Gloucester Walk,(j) Playfair Street, between Argyle Street and Atherden Street,(k) Kendall Lane, between Argyle Street and Mill Lane,(l) Mill Lane, between George Street and Playfair Street,(m) Gloucester Walk, between George Street and Argyle Street,(n) Cambridge Street, between Argyle Street and the intersection of Harrington Street and Gloucester Street,(o) Nurses Walk, between Globe Street and Suez Canal,(p) Suez Canal, between Harrington Street and George Street.	

public consultation draft

Road Transport (General) Regulation 2021 [NSW]
Schedule 2 Declared organisations

Column 1 Declared organisation	Column 2 Area of operations	Column 3 Responsible Minister
	<p>The Pyrmont Area of Sydney, comprising the following streets—</p> <ul style="list-style-type: none"> (a) Murray Street, between Union Street and Pirrama Road, (b) Pirrama Road, between Murray Street and Harris Street, (c) Darling Island, to its connection with Jones Bay Road, (d) Point Street, between Bowman Street and John Street, (e) Bowman Street, between Cross Street and Point Street, (f) Cross Street, between Bowman Street and Scott Street, (g) Scott Street, between Harris Street and Cross Street, (h) Refinery Drive, from Bowman Street to the northernmost point of Waterfront Park. <p>The Darling Harbour Development Area, comprising the following areas—</p> <ul style="list-style-type: none"> (a) the part of Sydney bounded by, but not including, King Street, Sussex Street, Harbour Street, Hay Street, Ultimo Road, Darling Drive, Pier Street, Harris Street, Allen Street and Murray Street, (b) Liverpool Street, between Harbour Street and Sussex Street. 	
Sydney Olympic Park Authority	Sydney Olympic Park within the meaning of the <i>Sydney Olympic Park Authority Act 2001</i> .	
TAFE Commission	St George College, Kogarah—being Lot 1, DP 853677.	
University of New England	Armidale campus—being the part of Armidale comprising the roads indicated on the maps marked “University of New England–Parking Scheme Area of Operations” and dated 23 February 2001 that have been lodged with the Authority before that date by the University of New England and that are available for inspection at each vehicular entrance to the Armidale Campus of the University of New England.	

public consultation draft

Road Transport (General) Regulation 2021 [NSW]
Schedule 2 Declared organisations

Column 1	Column 2	Column 3
Declared organisation	Area of operations	Responsible Minister
University of Newcastle	<p>Callaghan campus—being the part of Newcastle bounded by, but not including, University Drive, Highway Route 123, the main Northern Rail line and the Steelworks golf course.</p> <p>Newcastle CBD precinct—being the part of Newcastle bounded by, but not including, Auckland Street, Gibson Street, Laman Street and Charles Street.</p> <p>Central Coast campus—being the part of Ourimbah bounded by, but not including, Chittaway Road, Brush Road and the Northern Rail line.</p>	
University of New South Wales	<p>Kensington campus—being the part of Kensington bounded by, but not including, Anzac Parade, High Street, Botany Street and Barker Street.</p> <p>Randwick campus—being the part of Randwick bounded by, but not including, King Street, Darley Road, Govett Street and Govett Lane.</p> <p>Western campus—being the part of Kensington bounded by, but not including, Day Avenue and Anzac Parade.</p>	

public consultation draft

Road Transport (General) Regulation 2021 [NSW]
Schedule 2 Declared organisations

Column 1	Column 2	Column 3
Declared organisation	Area of operations	Responsible Minister
University of Sydney	<p>Camperdown campus—being the part of Camperdown bounded by, but not including, Parramatta Road, Missenden Road, Carillon Avenue and City Road.</p> <p>Darlington campus—being the part of Chippendale bounded by, but not including, City Road, Golden Grove Road, Abercrombie Street, Lander Street, Shepherd Street and Cleveland Street.</p> <p>Carillon campus—being the part of Newtown bounded by, but not including, Carillon Avenue, Missenden Road and Campbell Street.</p> <p>Graduate School of Management campus—being the part of Macdonaldtown bounded by, but not including, Burren Street and Watkin Street.</p> <p>Nursing Accommodation site—being the part of Camperdown bounded by, but not including, Mallet Street, Church Street and Hampshire Lane.</p> <p>Sydney College of the Arts campus—being the part of Rozelle bounded by, but not including, North Circuit and Central Avenue.</p> <p>Cumberland College campus—being the part of Lidcombe bounded by, but not including, Earl Street and Lidcombe Hospital.</p> <p>Camden Farms, being the following sites—</p> <ul style="list-style-type: none">(a) the part of Camden bounded by, but not including, Werombi Road and Grownlow Hill Loop Road,(b) the part of Camden bounded by, but not including, Werombi Road, Sickles Creek and Nepean River,(c) the part of Camden bounded by, but not including, Nepean River and Cobbitty Road (northern section),(d) the part of Camden bounded by, but not including, Nepean River and Cobbitty Road (southern section),(e) the part of Camden bounded by, but not including, Mayfarm Road and Mt Hunter Rivulet. <p>Orange campus—being the part of Orange bounded by, but not including, Leeds Road and Ophir Road.</p>	

public consultation draft

Road Transport (General) Regulation 2021 [NSW]
Schedule 2 Declared organisations

Column 1	Column 2	Column 3
Declared organisation	Area of operations	Responsible Minister
University of Technology Sydney	<p>City Campus—being the part of Ultimo bounded by, but not including, Jones Street, Thomas Street, Harris Street and Broadway.</p> <p>Haymarket Campus—being the part of Ultimo bounded by, but not including, Ultimo Road, Hay Street, Quay Street and Merino Boulevard.</p> <p>Blackfriars Campus—being the part of Chippendale bounded by, but not including, Buckland and Blackfriars Streets and Abercrombie Street.</p> <p>Kuring-gai Campus—being the part of Lindfield bounded by, but not including, Eton Road, Winchester Avenue, Lyle Avenue, Lady Game Drive and Lane Cove National Park.</p> <p>St Leonards Campus, Dunbar Building—being the part of St Leonards bounded by, but not including, the Pacific Highway, Westbourne Street, Royal North Shore Hospital and North Sydney College of TAFE.</p>	
Western Sydney University	<p>Bankstown campus—being the part of Milperra bounded by, but not including, Bullecourt Avenue, Horsley Road, Mount Saint Joseph Milperra, M5 Motorway and Ashford Avenue.</p> <p>Campbelltown campus—being the part of Campbelltown bounded by, but not including, M31 Hume Motorway, Narellan Road, TAFE NSW Campbelltown College, Goldsmith Avenue and Milky Way.</p> <p>Hawkesbury east campus—being the part of Richmond bounded by, but not including, Blacktown Road, The Driftway, Londonderry Road, College Street, Bourke Street, and TAFE NSW Richmond College.</p> <p>Hawkesbury west campus—being the part of Richmond bounded by, but not including, The Driftway, Londonderry Road, Southee Road and Castlereagh Road.</p> <p>Parramatta north campus—being the part of Parramatta bounded by, but not including, Victoria Road, Pemberton Street, Pennant Street, Collett Parade, James Ruse Drive and Kissing Point Road.</p> <p>Parramatta south campus—being the part of Parramatta bounded by, but not including, James Ruse Drive, Victoria Road, Clyde Carlingford Railway and Parramatta River.</p> <p>Penrith Werrington north campus—being Lot 101, DP 1140594.</p> <p>Penrith Werrington south campus—being Lot 100, DP 1194481 and Lot 3, DP 29796.</p> <p>Penrith Kingswood campus—being Lot 2, DP 1130750.</p>	

public consultation draft

Road Transport (General) Regulation 2021 [NSW]
Schedule 2 Declared organisations

Column 1	Column 2	Column 3
Declared organisation	Area of operations	Responsible Minister
University of Wollongong	<p>University of Wollongong, Wollongong (Main Campus)—being the part of Lot 1, DP 1163615 bounded by the M1 Princes Motorway, Madoline Street up to the Botanic Gardens, the Botanic Gardens end of Northfields Avenue and the part of Lot 1 west of the Robsons Road, bordered by Ken Auburn Track and Dallas Street.</p> <p>University of Wollongong Innovation Campus and Campus East Accommodation facilities, formerly known as Brandon Park, Fairy Meadow, bounded by Squires Way, Elliotts Road, Cowper Street, Montague Street and Para Creek.</p> <p>International House Student Residence bounded by the Sydney to Wollongong Rail Line, Hindmarsh Avenue and Memorial Drive.</p> <p>Weerona College Student Residence, Gwynneville, corner Foley Street and Throsby Drive backing on to the Wollongong Tennis Club’s tennis courts.</p> <p>Marketview Student Residence, Wollongong, bounded by Market and Church Streets, Lot 101, DP 11001956.</p> <p>Shoalhaven Campus, George Evans Road (Drive), Mundamia, Lot 6, DP 1156684.</p> <p>Bega Campus, bounded by Auckland Street, High Street, Little Church Street and Upper Street, Bega, Lot 1, DP 329413, 19 Little Church Street, Lot 2, DP 374951, 174 Auckland Street and Lot 24, DP 1091225, 176–178 Auckland Street.</p>	
Western Sydney Local Health District	<p>Auburn Hospital—being the part of Auburn bounded by, but not including, Hargrave Road, Norval Street, Havington Road and Water Street.</p> <p>Blacktown Hospital—being the part of Blacktown bounded by, but not including, Bungarribee Road, Blacktown Road, Panorama Parade and Marcel Crescent.</p> <p>Cumberland Hospital—being the part of Parramatta bounded by, but not including, Fleet Street, New Street, Parramatta Gaol and Toongabbie Creek.</p> <p>Mt Druitt Hospital—being the part of Mt Druitt bounded by, but not including, Luxford Road, Railway Street, North Parade and Mount Street.</p> <p>Lottie Stewart Hospital—being the part of Dundas bounded by, but not including, Stewart Street and Kissing Point Road.</p> <p>St Joseph’s Hospital—being the part of Auburn bounded by, but not including, Normanby Road, Alice Street, Mona Street and Cardigan Street.</p> <p>Westmead Hospital—being the part of Westmead bounded by, but not including, Darcy Road, Hawkesbury Road and Toongabbie Creek.</p>	

Schedule 3 Substances prescribed as drugs

clause 21

ALPRAZOLAM
AMYLOBARBITONE
AZATADINE
BARBITURIC ACID DERIVATIVES not otherwise specified in this Schedule
BENZODIAZEPINE DERIVATIVES not otherwise specified in this Schedule
BROMAZEPAM
BROMPHENIRAMINE
BUCLIZINE
BUPRENORPHINE
BUTOBARBITONE
CHLORAL HYDRATE
CHLORDIAZEPOXIDE
CHLORMETHIAZOLE
CHLORPHENIRAMINE
CHLORPHENTERMINE
CLEMASTINE
CLOBAZAM
CLONAZEPAM
CLORAZEPATE
CODEINE
CYCLIZINE
CYCLOBARBITONE
CYPROHEPTADINE
DEXCHLORPHENIRAMINE
DEXTROPROPOXYPHENE
DIAZEPAM
DIETHYLPROPION
DIHYDROCODEINE
DIMENHYDRINATE
DIMETHINDINE
DIPHENHYDRAMINE
DIPHENYLPRYALINE
DOXYLAMINE
EPHEDRINE, excluding pseudoephedrine
ETHYLMORPHINE
FENFLURAMINE
FLUNITRAZEPAM
FLURAZEPAM
GLUTETHIMIDE
HYDROXYZINE
LORAZEPAM
MAZINDOL
MEBHYDROLIN
MECLOZINE
MEDAZEPAM
MEPROBAMATE
MEPYRAMINE
METHDILAZINE
METHYLPHENOBARBITONE
MIDAZOLAM
NALBUPHINE
NITRAZEPAM

Road Transport (General) Regulation 2021 [NSW]
Schedule 3 Substances prescribed as drugs

OXAZEPAM
PENTAZOCINE
PENTOBARBITONE
PHENIRAMINE
PHENOBARBITONE
PHENTERMINE
PHENYLTOLOXAMINE
PIZOTIFEN
PRAZEPAM
PROMETHAZINE
PROPYLHEXEDRINE
QUINALBARBITONE
SECBUTOBARBITONE
TEMAZEPAM
THENYLDIAMINE
TRIAZOLAM
TRIMEPRAZINE
TRIPROLIDINE

Schedule 4 Authorised officers

clause 132

Class 1 officer means—

- (a) a person who is employed by Revenue NSW in the Department of Customer Service and who is authorised by the Commissioner of Fines Administration for the purposes of this definition, or
- (b) a person—
 - (i) whose services are made use of by Revenue NSW, whether by way of temporary hire arrangement, secondment or otherwise, and
 - (ii) who is authorised by the Commissioner of Fines Administration for the purposes of this definition, and
 - (iii) who is subject to the control and direction of the Commissioner of Fines Administration as an authorised officer.

Class 2 officer means a person—

- (a) employed in the Transport Service who is appointed as a class 2 enforcement officer, or
- (b) who is subject to the control and direction of Transport for NSW as a class 2 enforcement officer.

Class 3 officer means a person—

- (a) who is employed by the State Transit Authority as an enforcement officer, or
- (b) who is subject to the control and direction of the State Transit Authority as an enforcement officer.

Class 4 officer means a person who is appointed by the Point to Point Transport Commissioner as an authorised officer for the purposes of the *Point to Point Transport (Taxis and Hire Vehicles) Act 2016*.

Class 5 officer means an authorised officer within the meaning of the *Forestry Act 2012*.

Class 6 officer means a person—

- (a) who is an enforcement officer within the meaning of the *Protection of the Environment Operations Act 1997*, section 226, for an offence arising under that Act, section 145, and
- (b) who is—
 - (i) an officer or employee of the Department of Premier and Cabinet, or
 - (ii) subject to the control and direction of the Department of Premier and Cabinet.

Class 7 officer means—

- (a) a member of staff of Place Management NSW who is employed as an enforcement officer, or
- (b) a person who is subject to the control and direction of Place Management NSW as an enforcement officer.

Class 8 officer means a person—

- (a) who is employed in a government department as an enforcement officer, or
- (b) who is subject to the control and direction of the head of a government department as an enforcement officer.

Class 9 officer means a person—

- (a) who is employed by a corporation established by or under an Act as an enforcement officer, or
- (b) who is subject to the control and direction of a corporation as an enforcement officer.

Class 10 officer means a person—

public consultation draft

Road Transport (General) Regulation 2021 [NSW]
Schedule 4 Authorised officers

- (a) who is an authorised person within the meaning of the *Local Government Act 1993* for the purposes of that Act, section 679, and
- (b) who is—
 - (i) employed by a local council, or
 - (ii) subject to the control and direction of a local council.

Class 11 officer means a person who is appointed as an authorised officer under the Act, Part 7.1.

Class 12 officer means a person—

- (a) who is employed by a declared organisation as an enforcement officer, or
- (b) who is subject to the control and direction of a declared organisation as an enforcement officer.

Class 13 officer means a person employed in the Transport Service who is appointed as a Traffic Commander or a Transport Commander.

public consultation draft

Road Transport (General) Regulation 2021 [NSW]
Schedule 5 Penalty notice offences

Schedule 5 Penalty notice offences

clause 133

Local Government Act 1993

Column 1	Column 2	Column 3
Provision	Authorised officer	Penalty
Section 650(1), in relation to a notice or sign referred to in section 650(2)(a) or (b); Section 650(4); Section 650(5)	Class 1, 5, 6, 7, 10	Level 2
Section 650(1), in relation to a notice or sign referred to in section 650(2)(c)—space for the use of persons with disabilities	Class 1, 5, 6, 7, 10	Level 7
Section 650A(1), in relation to a notice or sign referred to in section 650A(2)(a) or (b); Section 650A(4); Section 650A(5)	Class 1, 7, 10	Level 2
Section 650A(1), in relation to a notice or sign referred to in section 650A(2)(c)—space for the use of persons with disabilities	Class 1, 7, 10	Level 7

Motor Accidents Compensation Act 1999

Column 1	Column 2	Column 3
Provision	Authorised officer	Penalty
Section 8	Class 1, 2	Level 8

Motor Vehicles Taxation Act 1988

Column 1	Column 2	Column 3
Provision	Authorised officer	Penalty
Section 9	Class 1, 2	Level 8

Road Rules 2014

Column 1	Column 2	Column 3
Provision	Authorised officer	Penalty
Rule 20, except where the applicable speed limit is specified by rule 24-2, 24-3 or 24-4—		
(a) if the vehicle is a class A motor vehicle and is otherwise than in a school zone—		
(i) driven at a speed of not more than 10 km/h above the speed limit applicable	Class 1	Level 2A

public consultation draft

Road Transport (General) Regulation 2021 [NSW]
Schedule 5 Penalty notice offences

Road Rules 2014

Column 1	Column 2	Column 3
Provision	Authorised officer	Penalty
(ii) driven at a speed of more than 10 km/h but not more than 20 km/h above the speed limit applicable	Class 1	Level 4A
(iii) driven at a speed of more than 20 km/h but not more than 30 km/h above the speed limit applicable	Class 1	Level 6A
(iv) driven at a speed of more than 30 km/h but not more than 45 km/h above the speed limit applicable	Class 1	Level 9A
(v) driven at a speed of more than 45 km/h above the speed limit applicable	Class 1	Level 14A
(b) if the vehicle is a class B motor vehicle and is otherwise than in a school zone—		
(i) driven at a speed of not more than 10 km/h above the speed limit applicable	Class 1	Level 5A
(ii) driven at a speed of more than 10 km/h but not more than 20 km/h above the speed limit applicable	Class 1	Level 6A
(iii) driven at a speed of more than 20 km/h but not more than 30 km/h above the speed limit applicable	Class 1	Level 7A
(iv) driven at a speed of more than 30 km/h but not more than 45 km/h above the speed limit applicable	Class 1	Level 9A
(v) driven at a speed of more than 45 km/h above the speed limit applicable	Class 1	Level 14A
(c) if the vehicle is a class C motor vehicle and is otherwise than in a school zone—		
(i) driven at a speed of not more than 10 km/h above the speed limit applicable	Class 1	Level 5A
(ii) driven at a speed of more than 10 km/h but not more than 20 km/h above the speed limit applicable	Class 1	Level 6A
(iii) driven at a speed of more than 20 km/h but not more than 30 km/h above the speed limit applicable	Class 1	Level 7A
(iv) driven at a speed of more than 30 km/h but not more than 45 km/h above the speed limit applicable	Class 1	Level 11A
(v) driven at a speed of more than 45 km/h above the speed limit applicable	Class 1	Level 16A

Rule 20, except where the applicable speed limit is specified by rule 24-2, 24-3 or 24-4—

- (a) if the vehicle is a class A motor vehicle and is in a school zone—

public consultation draft

Road Transport (General) Regulation 2021 [NSW]
Schedule 5 Penalty notice offences

Road Rules 2014

Column 1	Column 2	Column 3
Provision	Authorised officer	Penalty
(i) driven at a speed of not more than 10 km/h above the speed limit applicable	Class 1	Level 3A
(ii) driven at a speed of more than 10 km/h but not more than 20 km/h above the speed limit applicable	Class 1	Level 5A
(iii) driven at a speed of more than 20 km/h but not more than 30 km/h above the speed limit applicable	Class 1	Level 7A
(iv) driven at a speed of more than 30 km/h but not more than 45 km/h above the speed limit applicable	Class 1	Level 10A
(v) driven at a speed of more than 45 km/h above the speed limit applicable	Class 1	Level 15A
(b) if the vehicle is a class B motor vehicle and is in a school zone—		
(i) driven at a speed of not more than 10 km/h above the speed limit applicable	Class 1	Level 6A
(ii) driven at a speed of more than 10 km/h but not more than 20 km/h above the speed limit applicable	Class 1	Level 7A
(iii) driven at a speed of more than 20 km/h but not more than 30 km/h above the speed limit applicable	Class 1	Level 8A
(iv) driven at a speed of more than 30 km/h but not more than 45 km/h above the speed limit applicable	Class 1	Level 10A
(v) driven at a speed of more than 45 km/h above the speed limit applicable	Class 1	Level 15A
(c) if the vehicle is a class C motor vehicle and is in a school zone—		
(i) driven at a speed of not more than 10 km/h above the speed limit applicable	Class 1	Level 6A
(ii) driven at a speed of more than 10 km/h but not more than 20 km/h above the speed limit applicable	Class 1	Level 7A
(iii) driven at a speed of more than 20 km/h but not more than 30 km/h above the speed limit applicable	Class 1	Level 8A
(iv) driven at a speed of more than 30 km/h but not more than 45 km/h above the speed limit applicable	Class 1	Level 12A
(v) driven at a speed of more than 45 km/h above the speed limit applicable	Class 1	Level 17A

Rule 20, where the applicable speed limit is specified by rule 24-2—

public consultation draft

Road Transport (General) Regulation 2021 [NSW]
Schedule 5 Penalty notice offences

Road Rules 2014

Column 1	Column 2	Column 3
Provision	Authorised officer	Penalty
(a) if the vehicle is driven at a speed of not more than 10 km/h above the speed limit applicable	Class 1	Level 2A
(b) if the vehicle is driven at a speed of more than 10 km/h but not more than 20 km/h above the speed limit applicable	Class 1	Level 4A
(c) if the vehicle is driven at a speed of more than 20 km/h but not more than 30 km/h above the speed limit applicable	Class 1	Level 6A
(d) if the vehicle is driven at a speed of more than 30 km/h but not more than 45 km/h above the speed limit applicable	Class 1	Level 9A
(e) if the vehicle is driven at a speed of more than 45 km/h above the speed limit applicable	Class 1	Level 14A
Rule 20, where the applicable speed limit is specified by rule 24-3—		
(a) if the vehicle is a class A motor vehicle—		
(i) driven at a speed of not more than 10 km/h above the speed limit applicable	Class 1	Level 2A
(ii) driven at a speed of more than 10 km/h but not more than 20 km/h above the speed limit applicable	Class 1	Level 4A
(iii) driven at a speed of more than 20 km/h but not more than 30 km/h above the speed limit applicable	Class 1	Level 6A
(iv) driven at a speed of more than 30 km/h but not more than 45 km/h above the speed limit applicable	Class 1	Level 9A
(v) driven at a speed of more than 45 km/h above the speed limit applicable	Class 1	Level 14A
(b) if the vehicle is a class B motor vehicle—		
(i) driven at a speed of not more than 10 km/h above the speed limit applicable	Class 1	Level 5A
(ii) driven at a speed of more than 10 km/h but not more than 20 km/h above the speed limit applicable	Class 1	Level 6A
(iii) driven at a speed of more than 20 km/h but not more than 30 km/h above the speed limit applicable	Class 1	Level 7A
(iv) driven at a speed of more than 30 km/h but not more than 45 km/h above the speed limit applicable	Class 1	Level 9A
(v) driven at a speed of more than 45 km/h above the speed limit applicable	Class 1	Level 14A
(c) if the vehicle is a class C motor vehicle—		

public consultation draft

Road Transport (General) Regulation 2021 [NSW]
Schedule 5 Penalty notice offences

Road Rules 2014

Column 1	Column 2	Column 3
Provision	Authorised officer	Penalty
(i) driven at a speed of not more than 10 km/h above the speed limit applicable	Class 1	Level 5A
(ii) driven at a speed of more than 10 km/h but not more than 20 km/h above the speed limit applicable	Class 1	Level 6A
(iii) driven at a speed of more than 20 km/h but not more than 30 km/h above the speed limit applicable	Class 1	Level 7A
(iv) driven at a speed of more than 30 km/h but not more than 45 km/h above the speed limit applicable	Class 1	Level 11A
(v) driven at a speed of more than 45 km/h above the speed limit applicable	Class 1	Level 16A
Rule 20, where the applicable speed limit is specified by rule 24-4	Class 1	Level 2A
Rule 20, in relation to a bicycle and in circumstances other than where the applicable speed limit is specified by rule 24-2	Class 1	Level 2
Rule 27, Rule 28(1) and (1A), Rule 29, Rule 31, Rule 32(1), Rule 33, Rule 88, Rule 89, Rule 90, Rule 91, Rule 92, Rule 98, Rule 99, Rule 100—		
(a) in relation to a motor vehicle	Class 1	Level 4
(b) in relation to a bicycle	Class 1	Level 2
(c) in relation to a vehicle other than a motor vehicle or bicycle	Class 1	Level 1
Rule 28(2A), Rule 32(2A), Rule 35, Rule 141(2), Rule 245, Rule 246, Rule 247, Rule 247A, Rule 247B, Rule 248, Rule 249, Rule 250, Rule 251, Rule 252, Rule 253, Rule 255, Rule 257, Rule 258, Rule 259, Rule 260, Rule 261(1), Rule 262	Class 1	Level 2
Rule 37, Rule 39, Rule 40, Rule 41, Rule 42, otherwise than in school zone	Class 1	Level 4
Rule 37, Rule 39, Rule 40, Rule 41, Rule 42, in school zone	Class 1	Level 5
Rule 38, Rule 62, Rule 63, Rule 64(a), Rule 64(c), Rule 65(2)(a), Rule 65(2)(b), Rule 67(1), Rule 68(1), Rule 69(1), Rule 70, Rule 71, Rule 101, Rule 288, Rule 289, Rule 290, Rule 297(2), Rule 299, Rule 300, Rule 300-1, otherwise than in school zone	Class 1	Level 5
Rule 38, Rule 62, Rule 63, Rule 64(a), Rule 64(c), Rule 65(2)(a), Rule 65(2)(b), Rule 67(1), Rule 68(1), Rule 69(1), Rule 70, Rule 71, Rule 101, Rule 288, Rule 289, Rule 290, Rule 297(2), Rule 299, Rule 300, Rule 300-1, in school zone	Class 1	Level 6
Rule 46, Rule 48, Rule 51, Rule 53, Rule 112, Rule 113, Rule 117, Rule 118, Rule 141(1), Rule 153, Rule 162, Rule 163, Rule 164, Rule 164A	Class 1	Level 3
Rule 56, Rule 59, Rule 80, Rule 81, in relation to a vehicle other than a motor vehicle or a bicycle	Class 1	Level 1

public consultation draft

Road Transport (General) Regulation 2021 [NSW]
Schedule 5 Penalty notice offences

Road Rules 2014

Column 1	Column 2	Column 3
Provision	Authorised officer	Penalty
Rule 56(1), in relation to a motor vehicle otherwise than at toll booth or in school zone	Class 1	Level 6
Rule 56(1), in relation to a motor vehicle in school zone	Class 1	Level 7
Rule 56(1), in relation to a motor vehicle or bicycle at toll booth	Class 1	Level 3
Rule 56(1), Rule 59, in relation to a bicycle otherwise than at toll booth	Class 1	Level 6
Rule 56(2), Rule 80, Rule 81, Rule 82, in relation to a motor vehicle otherwise than in school zone	Class 1	Level 6
Rule 56(2), Rule 80, Rule 81, Rule 82, in relation to a motor vehicle in school zone	Class 1	Level 7
Rule 56(2), Rule 80, Rule 81, in relation to a bicycle	Class 1	Level 6
Rule 57, Rule 60, Rule 60A, Rule 61, Rule 64(b), Rule 65(2)(c), Rule 297(1), Rule 297(1A), Rule 297(3), otherwise than in school zone	Class 1	Level 6
Rule 57, Rule 60, Rule 60A, Rule 61, Rule 64(b), Rule 65(2)(c), Rule 297(1), Rule 297(1A), Rule 297(3), in school zone	Class 1	Level 7
Rule 59, in relation to a motor vehicle otherwise than at toll booth or in school zone	Class 1	Level 6
Rule 59, in relation to a motor vehicle in school zone	Class 1	Level 7
Rule 59, in relation to a motor vehicle or bicycle at toll booth	Class 1	Level 3
Rule 66, Rule 78, Rule 78–1, Rule 79, Rule 121, Rule 122, Rule 123, Rule 124, Rule 126, Rule 152, Rule 274, Rule 275, Rule 277, Rule 279, Rule 281, Rule 282, Rule 284, Rule 286, Rule 294	Class 1	Level 6
Rule 72, Rule 73, Rule 74, Rule 75, Rule 76, Rule 77, Rule 84, Rule 85, Rule 86, Rule 87, Rule 108, Rule 114, Rule 136, Rule 140, Rule 142, Rule 144, Rule 144–1, Rule 145, Rule 148, Rule 148A, Rule 149, Rule 154, Rule 157(1), Rule 159, Rule 224, Rule 224–1, Rule 264, Rule 265(1), Rule 266, Rule 267–1, Rule 268, Rule 268–2, Rule 268–3, Rule 269, Rule 270(1)(a), Rule 270(2), Rule 271(1)(a), Rule 271(2)(a), Rule 271(3) in the circumstances specified in Rule 271(2)(a), Rule 271(4), Rule 271(5), Rule 271(5A), Rule 271(5B), Rule 271(5C), Rule 271–1(1), Rule 271–2(1), Rule 287, Rule 298, Rule 298–1	Class 1	Level 5
Rule 79–1, Rule 79–2(1), Rule 218–1	Class 1	Level 2
Rule 82—		
(a) in relation to a bicycle	Class 1	Level 6
(b) in relation to a vehicle other than a motor vehicle or bicycle	Class 1	Level 1
Rule 83—		
(a) in relation to a motor vehicle	Class 1	Level 6
(b) in relation to a bicycle	Class 1	Level 2

public consultation draft

Road Transport (General) Regulation 2021 [NSW]
Schedule 5 Penalty notice offences

Road Rules 2014

Column 1	Column 2	Column 3
Provision	Authorised officer	Penalty
(c) in relation to a vehicle other than a motor vehicle or bicycle	Class 1	Level 1
Rule 93, Rule 94, Rule 95, Rule 96, Rule 97, Rule 101A, Rule 111, Rule 115, Rule 116, Rule 125, Rule 128, Rule 143, Rule 155, Rule 156	Class 1	Level 4
Rule 102—		
(a) in relation to a driver who drives through or under, or attempts to drive through or under, a tunnel, bridge or other structure to which a clearance sign or low clearance sign relates	Class 1, 2	Level 14
(b) in relation to a driver in circumstances other than referred to in paragraph (a)	Class 1, 2	Level 3
Rule 103	Class 1, 2, 11	Level 4
Rule 104(1) and (3)	Class 1, 2, 11	Level 3
Rule 104(2)—		
(a) in relation to a length of road other than the length of road referred to in paragraph (b)	Class 1, 2, 11	Level 3
(b) in relation to the length of road between Galston and Hornsby Heights that crosses Galston Gorge	Class 1, 2, 11	Level 14
Rule 105, Rule 107	Class 1, 2	Level 8
Rule 106(1) and (3)	Class 1, 2, 11	Level 3
Rule 106(2)—		
(a) in relation to a length of road other than the length of road referred to in paragraph (b)	Class 1, 2, 11	Level 3
(b) in relation to the length of road between Galston and Hornsby Heights that crosses Galston Gorge	Class 1, 2, 11	Level 14
Rule 119—		
(a) in relation to the rider of a bicycle	Class 1	Level 2
(b) in relation to a rider in circumstances other than referred to in paragraph (a)	Class 1	Level 1
Rule 127(1), in relation to a class B or class C motor vehicle in a Safe-T-Cam zone or average speed detection zone	Class 1, 2	Level 11
Rule 127(1), otherwise than in relation to a class B or class C motor vehicle in a Safe-T-Cam zone or average speed detection zone	Class 1	Level 6
Rule 128A, otherwise than in school zone	Class 1	Level 4
Rule 128A, in school zone	Class 1	Level 5
Rule 129, Rule 137, Rule 138—		
(a) in relation to a motor vehicle	Class 1	Level 4
(b) in relation to a bicycle	Class 1	Level 2

public consultation draft

Road Transport (General) Regulation 2021 [NSW]
Schedule 5 Penalty notice offences

Road Rules 2014

Column 1	Column 2	Column 3
Provision	Authorised officer	Penalty
(c) in relation to a vehicle other than a motor vehicle or bicycle Rule 130, Rule 131, Rule 135—	Class 1	Level 1
(a) in relation to a motor vehicle	Class 1	Level 5
(b) in relation to a bicycle	Class 1	Level 2
(c) in relation to a vehicle other than a motor vehicle or bicycle Rule 132—	Class 1	Level 1
(a) in relation to a class B or class C motor vehicle in a Safe-T-Cam zone or average speed detection zone	Class 1, 2	Level 11
(b) in relation to a class B or class C motor vehicle not in a Safe-T-Cam zone or average speed detection zone	Class 1	Level 5
(c) in relation to a motor vehicle that is not a class B or class C motor vehicle	Class 1	Level 5
(d) in relation to a bicycle	Class 1	Level 2
(e) in relation to a vehicle other than a vehicle referred to in paragraphs (a)–(d) Rule 146, Rule 147 and Rule 150(1)—	Class 1	Level 1
(a) in relation to a class B or class C motor vehicle in a Safe-T-Cam zone or average speed detection zone	Class 1, 2	Level 11
(b) otherwise than in relation to a class B or class C motor vehicle in a Safe-T-Cam zone or average speed detection zone Rule 151—	Class 1	Level 4
(a) in relation to the rider of a bicycle	Class 1	Level 2
(b) in relation to a rider in circumstances other than referred to in paragraph (a) Rule 151A(2)	Class 1	Level 1
Rule 155A	Class 1	Level 8
Rule 157–1(1)	Class 1	Level 4
Rule 157–1(2)	Class 1, 10, 13	Level 5
Rule 160, Rule 161, Rule 212, Rule 213, Rule 216, Rule 218, Rule 219, Rule 271(1)(b), Rule 271(1)(c), Rule 271(2)(b) and (3), Rule 272, Rule 296(2)	Class 1	Level 5
Rule 167, otherwise than in school zone	Class 1, 7, 10, 13	Level 2
Rule 167, in school zone	Class 1, 10, 13	Level 4
Rule 168, otherwise than in school zone	Class 1, 7, 10, 13	Level 5
Rule 168, in school zone	Class 1, 10, 13	Level 2
Rule 168–1	Class 1, 7, 8, 9, 10, 12, 13	Level 3

public consultation draft

Road Transport (General) Regulation 2021 [NSW]
Schedule 5 Penalty notice offences

Road Rules 2014

Column 1	Column 2	Column 3
Provision	Authorised officer	Penalty
Rule 169	Class 1, 7, 10, 13	Level 4
Rule 170(1), (2) and (3), otherwise than in school zone	Class 1, 7, 10, 13	Level 5
Rule 170(1), (2) and (3), in school zone	Class 1, 10, 13	Level 6
Rule 171(1), Rule 172(1), Rule 173(1), Rule 174(2), otherwise than in school zone	Class 1, 7, 10	Level 5
Rule 171(1), Rule 172(1), Rule 173(1), Rule 174(2), in school zone	Class 1, 10	Level 6
Rule 175(1)	Class 1, 10	Level 5
Rule 176	Class 1, 7, 10, 13	Level 4
Rule 177, Rule 178	Class 1, 10, 13	Level 4
Rule 179, Rule 180, Rule 181, Rule 190	Class 1, 7, 10	Level 3
Rule 179–1	Class 1, 7, 10, 12	Level 3
Rule 182(1)	Class 1, 2, 4, 7, 10, 14	Level 3
Rule 183(1), otherwise than in school zone	Class 1, 2, 3, 7, 10	Level 4
Rule 183(1), in school zone	Class 1, 2, 3, 10	Level 5
Rule 184(1), in relation to a minibus zone in a clearway, transit lane or bus lane	Class 1, 2, 3, 7, 10	Level 3
Rule 184(1), otherwise than in relation to a minibus zone in a clearway, transit lane or bus lane	Class 1, 2, 3, 7, 10	Level 2
Rule 186	Class 1, 2, 7, 10	Level 2
Rule 187(1)	Class 1, 2, 7, 10, 13	Level 4
Rule 187(2), Rule 187(3)	Class 1, 7, 10, 13	Level 4
Rule 188, Rule 193, Rule 194, Rule 199, Rule 200, Rule 201, Rule 202, Rule 205, Rule 208A, Rule 209, Rule 210, Rule 211	Class 1, 7, 10	Level 2
Rule 189, otherwise than in school zone	Class 1, 7, 10	Level 4
Rule 189, in school zone	Class 1, 10	Level 5
Rule 191, Rule 192, Rule 203A	Class 1, 7, 10, 13	Level 3
Rule 195(1), otherwise than in school zone	Class 1, 2, 7, 10	Level 4
Rule 195(1), in school zone	Class 1, 2, 10	Level 5
Rule 195(1–1), otherwise than in school zone	Class 1, 2, 7, 10	Level 4
Rule 195(1–1), in school zone	Class 1, 2, 10	Level 5
Rule 196(1)	Class 1, 2, 10	Level 3
Rule 197(1), Rule 198(1) and (2), otherwise than in school zone	Class 1, 7, 10	Level 4
Rule 197(1), Rule 198(1) and (2), in school zone	Class 1, 10	Level 5
Rule 197(1A), Rule 197(1B), otherwise than in school zone	Class 1, 7, 10	Level 2

public consultation draft

Road Transport (General) Regulation 2021 [NSW]
Schedule 5 Penalty notice offences

Road Rules 2014

Column 1	Column 2	Column 3
Provision	Authorised officer	Penalty
Rule 197(1A), Rule 197(1B), in school zone	Class 1, 10	Level 3
Rule 203(1)	Class 1, 7, 10, 12	Level 7
Rule 205A-1(1)	Class 1, 7, 10, 12, 13	Level 4
Rule 207, Rule 207-7	Class 1, 7, 10, 12	Level 2
Rule 208(1), arising from a breach of Rule 208(2), otherwise than in school zone	Class 1, 7, 10	Level 4
Rule 208(1), arising from a breach of Rule 208(2), in school zone	Class 1, 10	Level 5
Rule 208(1), arising from a breach of Rule 208(3), (4), (5), (7) or (8)	Class 1, 7, 10	Level 2
Rule 208(1), arising from a breach of Rule 208(6), otherwise than in school zone	Class 1, 7, 10	Level 4
Rule 208(1), arising from a breach of Rule 208(6), in school zone	Class 1, 10	Level 5
Rule 215-1, in relation to a class B or class C motor vehicle in a Safe-T-Cam zone or average speed detection zone	Class 1, 2	Level 11
Rule 215-1, otherwise than in relation to a class B or class C motor vehicle in a Safe-T-Cam zone or average speed detection zone	Class 1	Level 2
Rule 220-1(1)	Class 1	Level 2
Rule 221-1, Rule 294-3, Rule 300-5	Class 1, 2	Level 2
Rule 221-2	Class 1	Level 2
Rule 222-1, Rule 300-4	Class 1, 2	Level 5
Rule 222-2, Rule 291-1	Class 1, 2	Level 3
Rule 223, Rule 228, Rule 229, Rule 230, Rule 231, Rule 232, Rule 233, Rule 234, Rule 235, Rule 235A, Rule 236, Rule 237, Rule 238, Rule 239, Rule 240A, Rule 240, Rule 241, Rule 242, Rule 243, Rule 244, Rule 301, Rule 302, Rule 303	Class 1	Level 1
Rule 226, Rule 227	Class 1, 2	Level 2
Rule 245-1	Class 1	Level 6
Rule 254, 256	Class 1	Level 5
Rule 265(3), where driver drives with 1 unrestrained passenger	Class 1	Level 5
Rule 265(3), where driver drives with 2 unrestrained passengers	Class 1	Level 8
Rule 265(3), where driver drives with 3 unrestrained passengers	Class 1	Level 10
Rule 265(3), where driver drives with 4 or more unrestrained passengers	Class 1	Level 12
Rule 270(1)(a) and (b), where unhelmeted rider rides bike with 1 unhelmeted passenger only	Class 1	Level 8

public consultation draft

Road Transport (General) Regulation 2021 [NSW]
Schedule 5 Penalty notice offences

Road Rules 2014

Column 1	Column 2	Column 3
Provision	Authorised officer	Penalty
Rule 270(1)(a) and (b), where unhelmeted rider rides bike with 2 unhelmeted passengers	Class 1	Level 10
Rule 270(1)(a) and (b), where unhelmeted rider rides bike with 3 unhelmeted passengers	Class 1	Level 12
Rule 270(1)(a) and (b), where unhelmeted rider rides bike with 4 or more unhelmeted passengers	Class 1	Level 13
Rule 270(1)(b), where helmeted rider rides bike with 1 unhelmeted passenger only	Class 1	Level 5
Rule 270(1)(b), where helmeted rider rides bike with 2 unhelmeted passengers	Class 1	Level 8
Rule 270(1)(b), where helmeted rider rides bike with 3 unhelmeted passengers	Class 1	Level 10
Rule 270(1)(b), where helmeted rider rides bike with 4 or more unhelmeted passengers	Class 1	Level 12
Rule 291	Class 1, 2	Level 5
Rule 291–2	Class 1, 2, 13	Level 3
Rule 292(a), Rule 292(b)	Class 1, 2, 10	Level 6
Rule 292(c)	Class 1, 2	Level 6
Rule 293(2)	Class 1, 2, 13	Level 6
Rule 294–1, Rule 294–2	Class 1, 2	Level 6
Rule 296(1), otherwise than in school zone	Class 1	Level 3
Rule 296(1), in school zone	Class 1	Level 4
Rule 300–2(1)	Class 1	Level 6
Rule 304(1)	Class 1, 13	Level 5
Rule 316–2(1)	Class 1, 2, 10, 13	Level 3

Road Transport Act 2013

Column 1	Column 2	Column 3
Provision	Authorised officer	Penalty
Section 50	Class 1	Level 9
Section 53(1)(a); Section 53(1)(b)—		
(a) where the driver held a licence under the Act, excluding a licence appropriate to the class of vehicle driven that is a class of vehicle that requires a Class C, Class R, Class LR or Class MR licence—		
(i) for the first offence, or the first offence within the last 5 years	Class 1, 2	Level 7

public consultation draft

Road Transport (General) Regulation 2021 [NSW]
Schedule 5 Penalty notice offences

Road Transport Act 2013

Column 1	Column 2	Column 3
Provision	Authorised officer	Penalty
(ii) for the second or subsequent offence within the last 5 years	Class 1, 2	Level 9
(b) where the driver held a licence under the Act, excluding a licence appropriate to the class of vehicle driven that is a class of vehicle that requires a Class HR, Class HC or Class MC licence—		
(i) for the first offence, or the first offence within the last 5 years	Class 1, 2	Level 8
(ii) for the second or subsequent offence within the last 5 years	Class 1, 2	Level 11
(c) where the driver held a licence issued under the law in force in another State or Territory, but had resided continuously in New South Wales during the previous 3 months—		
(i) for the first offence, or the first offence within the last 5 years	Class 1, 2	Level 7
(ii) for the second or subsequent offence within the last 5 years	Class 1, 2	Level 9
(d) where the driver held a licence under the Act that had expired less than 2 years before—		
(i) for the first offence, or the first offence within the last 5 years	Class 1, 2	Level 7
(ii) for the second or subsequent offence within the last 5 years	Class 1, 2	Level 9
(e) where the driver held a licence under the Act that had expired 2 years or more before—		
(i) for the first offence, or the first offence within the last 5 years	Class 1, 2	Level 8
(ii) for the second or subsequent offence within the last 5 years	Class 1, 2	Level 11
(f) where the driver had never been licensed within the meaning of section 53(5), for the first offence only	Class 1, 2	Level 9
Section 68(1)—		
(a) if the vehicle is a class A motor vehicle	Class 1, 2	Level 8
(b) if the vehicle is a class A motor vehicle that is a motor vehicle and trailer combination, where the motor vehicle is registered and the towed trailer is unregistered	Class 1, 2	Level 3
(c) if the vehicle is a class B or class C motor vehicle	Class 1, 2	Level 12
(d) if a trailer is left standing on a road that is not part of a combination	Class 1, 2, 10	Level 3
Section 73(3); Section 75(2)	Class 1, 2	Level 12
Section 90(1); Section 92(1); Section 96; Section 97; Section 104G(1); Section 104I(1); Section 104M; Section 104N	Class 2	Level 8

public consultation draft

Road Transport (General) Regulation 2021 [NSW]
Schedule 5 Penalty notice offences

Road Transport Act 2013

Column 1	Column 2	Column 3
Provision	Authorised officer	Penalty
Section 91; Section 92(2); Section 93; Section 94; Section 98(6); Section 104H; Section 104I(2); Section 104J; Section 104K; Section 104O(6)	Class 2	Level 12
Section 110(1)–(3) if, in the 5 years before the offence, the person—	Class 1	Level 7
(a) has not been issued a penalty notice for an alcohol or other drug related driving offence, or		
(b) convicted of the same or an equivalent offence referred to in paragraph (a)		
Section 111(1) if, in the 5 years before the offence, the person—	Class 1	Level 7
(a) has not been issued a penalty notice for an alcohol or other drug related driving offence, or		
(b) convicted of the same or an equivalent offence referred to in paragraph (a)		
Section 116(1)	Class 1	Level 8
Section 117(1)(c)	Class 1	Level 6
Section 119; Section 120(3)	Class 1	Level 13
Section 143(6)	Class 1, 2	Level 5
Section 162	Class 1, 2	Level 14
Section 169A(7)	Class 1, 2	Level 5
Section 175(2)(a) or (b)	Class 1, 2	Level 2
Section 177(1)	Class 1, 2	Level 9
Section 188(1)—		
(a) if the offence relates to a vehicle registered otherwise than in the name of a natural person—		
(i) for the first offence, or the first offence within the last 5 years	Class 1	Level 12
(ii) for the second or subsequent offence within the last 5 years	Class 1	Level 17
(b) in any other case	Class 1	Level 8
Section 188(2)—		
(a) if the offence relates to a vehicle registered otherwise than in the name of a natural person	Class 1	Level 12
(b) in any other case	Class 1	Level 8
Section 189(4)—		
(a) if the person served with the verification notice is an individual	Class 1	Level 8
(b) if the person served with the verification notice is a corporation—		

public consultation draft

Road Transport (General) Regulation 2021 [NSW]
Schedule 5 Penalty notice offences

Road Transport Act 2013

Column 1	Column 2	Column 3
Provision	Authorised officer	Penalty
(i) for the first offence, or the first offence within the last 5 years	Class 1	Level 12
(ii) for the second or subsequent offence within the last 5 years	Class 1	Level 17
Section 192(3)	Class 1	Level 8
Section 239(2); Section 244(1)–(3)	Class 1	Level 14
Section 243(1) and (2)	Class 1	Level 15
Section 244(4)	Class 1	Level 9

Road Transport (Driver Licensing) Regulation 2017

Column 1	Column 2	Column 3
Provision	Authorised officer	Penalty
Clause 9(2); Clause 9(3)	Class 1, 2	Level 2
Clause 15(1)(a)	Class 1	Level 9
Clause 15(1)(b); Clause 17(1)(a); Clause 17(1)(b); Clause 18(a); Clause 18(b); Clause 23(a); Clause 23(b)	Class 1	Level 4
Clause 16(a); Clause 16(b); Clause 19; Clause 39(6); Clause 39(8); Clause 96(14); Clause 122(1)(a); Clause 122(1)(b); Clause 122(1)(c)	Class 1	Level 2
Clause 17(2)	Class 1	Level 7
Clause 39(7)	Class 1	Level 5
Clause 93(3)	Class 1	Level 13
Clause 119(1), where the licence concerned is an interlock driver licence—		
(a) in relation to a condition imposed by clause 83(3)	Class 1	Level 13
(b) in relation to a condition imposed by clause 85(1)(e) or (f)	Class 1	Level 13
Clause 119(1), otherwise than where the licence concerned is an interlock driver licence—		
(a) in relation to a condition imposed by clause 22(1)(b) or 29(1)(b)— for the first offence, or the first offence within the last 5 years	Class 1	Level 7
(b) in relation to a condition imposed by clause 22(1)(b) or 29(1)(b)—for the second or subsequent offence within the last 5 years	Class 1	Level 9
(c) in relation to a condition imposed by clause 22(1)(c)	Class 1	Level 5
(d) in relation to a condition imposed by clause 36, 37 or 38	Class 1	Level 7
(e) in relation to a licence condition not referred to in paragraphs (a)–(d)	Class 1	Level 4

public consultation draft

Road Transport (General) Regulation 2021 [NSW]
Schedule 5 Penalty notice offences

Road Transport (Driver Licensing) Regulation 2017

Column 1	Column 2	Column 3
Provision	Authorised officer	Penalty
Clause 120; Clause 121; Clause 123(2)	Class 1, 2	Level 2

Road Transport (General) Regulation 2021

Column 1	Column 2	Column 3
Provision	Authorised officer	Penalty
Clause 11(1)	Class 1	Level 6
Clause 14(1)	Class 1	Level 2
Clause 17(1); Clause 18(1); Clause 19(2)	Class 1, 2	Level 5
Clause 19(3); Clause 20(2); Clause 20(3)	Class 1, 2	Level 3
Clause 27(1); Clause 27(3)	Class 1, 2, 7, 10, 13	Level 3
Clause 28(1)	Class 1, 2, 10, 13	Level 3
Clause 52(1), in relation to a contravention of a requirement of clause 55(1) or 66	Class 1, 2, 5, 6, 10, 11	Level 9
Clause 52(1), in relation to a contravention of a requirement of clause 60	Class 1, 2, 5, 6, 10, 11	Level 3
Clause 59(4)	Class 1, 2	Level 4
Clause 64	Class 1, 2	Level 4
Clause 67(a); Clause 67(b)	Class 1, 2, 10, 11	Level 4
Clause 67(c)	Class 1, 2, 10, 11	Level 6
Clause 72(1)	Class 1, 2, 5, 6, 10, 11	Level 3
Clause 88(1); Clause 89(a); Clause 89(d); Clause 123(1); Clause 124(a); Clause 124(d); Clause 124(e)	Class 1, 7, 10, 12	Level 4
Clause 89(b); Clause 89(c); Clause 124(b); Clause 124(c)	Class 1, 7, 10, 12	Level 3
Clause 106(2)	Class 1, 2	Level 2
Clause 108(1); Clause 108(3)	Class 1, 2	Level 2
Clause 114; Clause 115; Clause 116; Clause 117(2); Clause 118(3); Clause 119(4); Clause 119(5)	Class 1, 2, 5, 6, 7, 8, 9, 10, 11, 12, 13	Level 8
Clause 163(6), if the offence arises because the laden mass of the vehicle exceeds the maximum specified by the limit notice—		
(a) by not more than 1 tonne	Class 1, 2, 10, 11	Level 5
(b) by more than 1 tonne but not more than 2 tonnes	Class 1, 2, 10, 11	Level 8
(c) by more than 2 tonnes but not more than 3 tonnes	Class 1, 2, 10, 11	Level 10
(d) by more than 3 tonne but not more than 4 tonnes	Class 1, 2, 10, 11	Level 11

public consultation draft

Road Transport (General) Regulation 2021 [NSW]
Schedule 5 Penalty notice offences

Road Transport (Vehicle Registration) Regulation 2017

Column 1	Column 2	Column 3
Provision	Authorised officer	Penalty
Clause 23(4); Clause 29(1); Clause 30(1); Clause 31; Clause 36(8); Clause 37(1); Clause 37(3); Clause 37(4); Clause 37(6); Clause 37(7); Clause 39(1); Clause 42(3); Clause 43(4); Clause 47(5); Clause 52(3); Clause 53; Clause 54; Clause 55; Clause 56(2); Clause 56(3); Clause 60(1) except in relation to a matter provided for elsewhere in this Table; Clause 60(2); Clause 60(4); Clause 60(5); Clause 66(4); Clause 68(8); Clause 68(9); Clause 69(4); Clause 77(1); Clause 77(2); Clause 77(3); Clause 78; Clause 80(7); Clause 128(1); Clause 129(2); Clause 130(1); Clause 130(3)	Class 1, 2	Level 2
Clause 34(1) and (2)	Class 1	Level 15
Clause 60(1)(a), if the vehicle is a class A motor vehicle	Class 1, 2	Level 6
Clause 60(1)(a), if the vehicle is a class B motor vehicle	Class 1, 2	Level 8
Clause 60(1)(a), if the vehicle is a class C motor vehicle	Class 1, 2	Level 8
Clause 60(1)(b)(i), if the vehicle is a light vehicle that does not comply with the following provisions of the Light Vehicle Standards Rules—		
(a) rule 25C(b), vehicle cause danger or unreasonable annoyance	Class 1, 2	Level 3
(b) rule 26, defective steering	Class 1, 2	Level 5
(c) rule 29(3), motor vehicle fitted with a vehicle frontal protection system, for example a bullbar, roobar or nudge bar, failing to comply with the document titled <i>Technical specification: Requirements for vehicle frontal protection systems fitted to light vehicles</i> published on a publicly accessible website maintained by Transport for NSW and as in force from time to time because of—	Class 1, 2	Level 3
(i) incorrect method of mounting vehicle frontal protection system, or		
(ii) exposed edges, or		
(iii) unacceptable shape of material or unacceptable profile of vehicle frontal protection system, or		
(iv) use of non-standard or non-approved vehicle frontal protection system		

public consultation draft

Road Transport (General) Regulation 2021 [NSW]
Schedule 5 Penalty notice offences

Road Transport (Vehicle Registration) Regulation 2017

Column 1	Column 2	Column 3
Provision	Authorised officer	Penalty
(d) rule 29(3), motor vehicle fitted with a vehicle frontal protection system, for example a bullbar, roobar or nudge bar, failing to comply with the document titled <i>Technical specification: Requirements for vehicle frontal protection systems fitted to light vehicles</i> published on a publicly accessible website maintained by Transport for NSW and as in force from time to time because of dangerous protrusions fitted to vehicle frontal protection system, for example— (i) fishing rod holders, (ii) aerials, (iii) winches, (iv) brackets for the mounting of spot lamps	Class 1, 2	Level 5
(e) rule 29A, oil and grease leaks	Class 1, 2	Level 3
(f) rule 31, defective seating	Class 1, 2	Level 5
(g) rule 31A, seatbelt removed or defective	Class 1, 2	Level 5
(h) rule 31A, motor vehicle not fitted or equipped with seatbelts or seatbelt anchorages	Class 1, 2	Level 5
(i) rules 119–121 or 123–128, defective brakes	Class 1, 2	Level 5
(j) rule 122, defective brake other than a defective emergency brake	Class 1, 2	Level 5
(k) rules 130, 134, 137 or 139–141, undue emission, inefficient silencer or excessive noise	Class 1, 2	Level 3
(l) rule 143 or 144, defective LPG or natural gas equipment or labelling	Class 1, 2	Level 3
Clause 60(1)(b)(ii)	Class 1, 2	Level 3
Clause 64(1)	Class 1, 2	Level 8
Clause 68(10); Clause 69(6)	Class 1, 2	Level 4
Clause 80(4)	Class 1, 2	Level 5
Clause 81(6)	Class 1, 2	Level 5
Clause 84(1)	Class 1, 2	Level 9
Clause 85(2); Clause 85(5); Clause 93(1); Clause 93(2); Clause 93(3)	Class 2	Level 8
Clause 85(6)	Class 2	Level 5
Clause 90(5); Clause 94(2); Clause 94(3); Clause 95(1); Clause 95(2)	Class 2	Level 9
Clause 109(2); Clause 112(1); Clause 112(2); Clause 121(1); Clause 123Q(2); Clause 123R(1) and (2); Clause 123ZA(1)	Class 1, 2	Level 5
Clause 116; Clause 123V	Class 2	Level 8
Clause 119(1) and (3); Clause 121(3); Clause 123Y(1) and (3); Clause 123ZA(3)	Class 2	Level 12
Clause 128(2), if the defect notice is a minor defect notice	Class 1, 2	Level 5

public consultation draft

Road Transport (General) Regulation 2021 [NSW]
Schedule 5 Penalty notice offences

Road Transport (Vehicle Registration) Regulation 2017

Column 1	Column 2	Column 3
Provision	Authorised officer	Penalty
Clause 128(2), if the defect notice is a major defect notice	Class 1, 2	Level 6
Clause 128(3); Clause 128(5)	Class 1, 2	Level 8
Clause 129(1), Clause 129(3), if the vehicle is a class A motor vehicle	Class 1, 2	Level 6
Clause 129(4), if the vehicle is a class A motor vehicle	Class 1, 2	Level 2
Clause 129(1), Clause 129(3), Clause 129(4), if the vehicle is a class B motor vehicle or class C motor vehicle	Class 1, 2	Level 8

Roads Act 1993

Column 1	Column 2	Column 3
Provision	Authorised officer	Penalty
Section 115(4)	Class 1, 2, 11	Level 2

Schedule 6 Lower penalty levels for certain parking offences

clause 135

Part 1 Councils that have opted to participate

Blacktown City Council
Bland Council
Camden Council
Central Coast Council
Cessnock City Council
Clarence Valley Council
Eurobodalla Council
Fairfield City Council
Forbes Council
Glen Innes Severn Council
Inverell Council
Lachlan Council
Liverpool City Council
Muswellbrook Council
Nambucca Council
Richmond Valley Council
Shoalhaven City Council
The Hills Council
Wagga Wagga City Council
Wingecarribee Council
Yass Valley Council

Part 2 Universities that have opted to participate

Charles Sturt University
Macquarie University
University of Newcastle
University of Technology Sydney
University of Wollongong
Western Sydney University

Schedule 7 Amendment of other legislation

7.1 City of Sydney Act 1988 No 48

Section 51B Definitions

Omit “*Road Transport (General) Regulation 2013*” from definition of *Sydney CBD parking authority*.

Insert instead “*Road Transport (General) Regulation 2021*”.

7.2 Heavy Vehicle (Adoption of National Law) Act 2013 No 42

Schedule 2 Modification of national regulations as applying in New South Wales

Omit “see rules 222–1, 222–2 and 300–4 of the *Road Rules 2014* and clauses 24 and 25 of the *Road Transport (General) Regulation 2013*” from Schedule 2.1, item 1, Division 16, note.

Insert instead “see the *Road Rules 2014*, rules 222–1, 222–2 and 300–4 and the *Road Transport (General) Regulation 2021*, clauses 17 and 18”.

7.3 Heavy Vehicle (Vehicle Standards) National Regulation (NSW)

Schedule 2 Other vehicle standards applying to single heavy vehicles

Omit “see rules 222–1, 222–2 and 300–4 of the *Road Rules 2014* and clauses 24 and 25 of the *Road Transport (General) Regulation 2013*” from Part 6, Division 16, note.

Insert instead “see the *Road Rules 2014*, rules 222–1, 222–2 and 300–4 and the *Road Transport (General) Regulation 2021*, clauses 17 and 18”.

7.4 Local Government (General) Regulation 2005

[1] Clause 413 Parking and related offences for purposes of section 694

Omit “section 195 of the *Road Transport Act 2013* by a Class 12 officer referred to in Schedule 4 to the *Road Transport (General) Regulation 2013* is declared to be a parking or related offence for the purposes of section 694 of the Act”.

Insert instead “the *Road Transport Act 2013*, section 195, by a Class 10 officer referred to in the *Road Transport (General) Regulation 2021*, Schedule 4, is declared to be a parking or related offence for the purposes of the Act, section 694”.

[2] Clause 413, note

Omit “*Class 12 officer*”. Insert instead “*Class 10 officer*”.

7.5 Marine Estate Management (Management Rules) Regulation 1999

[1] Clause 5.13 Special purpose zones—fishing

Omit “Division 2 of Part 6 of the *Road Transport (General) Regulation 2013*” from clause 5.13(4)(a).

Insert instead “the *Road Transport (General) Regulation 2021*, Part 7, Division 2”.

[2] Clause 5.13(4)(b)

Omit “Division 2 of Part 6”. Insert instead “Part 7, Division 2”.

7.6 Motor Dealers and Repairers Regulation 2014

Clause 56 Penalty notice offences

Omit clause 56(e). Insert instead—

(e) a Class 10 officer authorised in writing by the Secretary.

(2) In this clause—

Class 10 officer has the same meaning as in the *Road Transport (General) Regulation 2021*, Schedule 4.

7.7 National Parks and Wildlife Regulation 2019

Clause 10 Use of vehicles, animals, vessels and machines in parks

Omit “*Road Transport (General) Regulation 2013*” from clause 10(7), definition of **mobility parking scheme authority**.

Insert instead “*Road Transport (General) Regulation 2021*”.

7.8 Photo Card Regulation 2014

Clause 10 Purposes for which photographs may be kept and used

Omit “Division 2 (Mobility parking scheme authorities) of Part 6 of the *Road Transport (General) Regulation 2013*”.

Insert instead “the *Road Transport (General) Regulation 2021*, Part 7 (Mobility parking scheme authorities)”.

7.9 Protection of the Environment Operations (General) Regulation 2009

Clause 94 Prohibition on placing advertising material on vehicles

Omit “*Road Transport (General) Regulation 2013*” from clause 94(2).

Insert instead “*Road Transport (General) Regulation 2021*”.

7.10 Road Rules 2014

[1] Whole of the Rules (except where otherwise amended by this subschedule)

Omit “*Road Transport (General) Regulation 2013*” wherever occurring.

Insert instead “*Road Transport (General) Regulation 2021*”.

[2] Rule 21–1 NSW rule: school bus stop zone sign is speed limit sign

Omit “clause 25 of the *Road Transport (General) Regulation 2013*” from rule 21–1(3), definition of **warning system**.

Insert instead “the *Road Transport (General) Regulation 2021*, clause 18”.

[3] Rule 24–3 NSW rule: speed limit when bus displaying when lights flash speed limit sign

Omit “clause 25 of the *Road Transport (General) Regulation 2013*” from rule 24–3(5), definition of **warning system**.

Insert instead “the *Road Transport (General) Regulation 2021*, clause 18”.

- [4] **Rule 179 Stopping in a loading zone**
Omit rule 179(1)(c)(ii).
- [5] **Rule 179(1)(c)(iii)**
Omit “(other than a vehicle referred to in subparagraph (ii))”.
- [6] **Rule 179(2)(c)(ii)**
Omit the subparagraph.
- [7] **Rule 179(2)(c)(iii)**
Omit “(other than a vehicle referred to in subparagraph (ii))”.
- [8] **Rule 179(2), note 1**
Omit the note. Insert instead—
Note 1. *Motor vehicle* and *with* are defined in the Dictionary.
- [9] **Rule 179(3–1)**
Omit “ticket-operated loading zone”. Insert instead “controlled loading zone”.
- [10] **Rule 179(3–1), note 1**
Omit “*ticket-operated loading zone*”. Insert instead “*controlled loading zone*”.
- [11] **Rule 179(3–1), note 2**
Omit “ticket-operated loading zones”. Insert instead “controlled loading zones”.
- [12] **Rule 179–1**
Omit the rule. Insert instead—
- 179–1 NSW rule: stopping in controlled loading zone**
- (1) This rule applies to a driver who stops a goods vehicle in a controlled loading zone.
Note. *Goods vehicle* is defined in the Dictionary.
- (2) A ***controlled loading zone*** is a length of road to which a *loading zone sign* applies where information on or with the sign—
(a) indicates the the length of road is controlled by a loading zone device, or
(b) includes the words “CONTROLLED”, “TICKET” or “METER”.
Note. *With* is defined in the Dictionary.
- (3) A driver must obey instructions, if any, on or with the *loading zone sign* or a loading zone device used in connection with the controlled loading zone.
Maximum penalty—20 penalty units.
Note. *Loading zone device* is defined in the Dictionary.
- (4) If the instructions referred to in subrule (3) require a loading zone ticket to be printed, the printed loading zone ticket must be displayed in or on the vehicle in a way making its date and expiry time clearly visible to persons outside the vehicle.
Maximum penalty—20 penalty units.
- (5) A driver does not commit an offence under subrule (3) or (4) if the driver—

public consultation draft

Road Transport (General) Regulation 2021 [NSW]
Schedule 7 Amendment of other legislation

- (a) stops a goods vehicle in a controlled loading zone before complying with subrule (3) or (4), so long as the person complies with subrules (3) and (4) immediately after stopping the vehicle, or
 - (b) is driving a vehicle engaged in dropping off, or picking up, passengers.
- (6) The driver of a goods vehicle must not allow the vehicle to remain stopped in a controlled loading zone after the expiry of the loading zone ticket.
Maximum penalty—20 penalty units.
- (7) A driver must not stop in a controlled loading zone closed under the *Road Transport (General) Regulation 2021*.
Maximum penalty—20 penalty units.
Note. The *Road Transport (General) Regulation 2021*, clause 125 enables a parking authority to temporarily close a controlled loading zone by erecting a sign to that effect in, or in close proximity to, the zone.
- (8) This rule prevails over other parking restrictions that may apply within a controlled loading zone, and those restrictions do not apply, and may not be enforced, in relation to a goods vehicle stopped in a controlled loading zone in accordance with this rule.

Loading zone sign

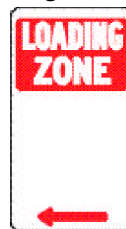

Note 1 for diagram. There is another permitted version of the *loading zone sign*—see the diagram in Schedule 3.

Note 2 for diagram. A *loading zone sign* may have an arrow pointing in a different direction and anything on the sign may be differently arranged—see rule 316(4).

Note. This rule is an additional NSW road rule. There is no corresponding rule in the *Australian Road Rules*.

[13] Rule 205A–1 NSW rule: parking in special event parking areas

Omit rule 205A–1(5)(b)(ii) and (iii). Insert instead—

- (ii) is parked in accordance with the terms of the permit,

[14] Rule 205A–1(5), note

Omit the note. Insert instead—

Note. *Public utility service vehicle* is defined in the Dictionary

[15] Rule 205A–1(7), definition of “special event parking permit”

Omit “of the kind referred to in clause 95(2)(e) of the *Road Transport (General) Regulation 2013*”.

Insert instead “issued by Transport for NSW in accordance with a special event parking scheme established under the *Road Transport (General) Regulation 2021*, clause 127, for use of a special event parking area”.

public consultation draft

Road Transport (General) Regulation 2021 [NSW]
Schedule 7 Amendment of other legislation

[16] Rule 206 Time extension for people with disabilities

Omit “Division 2 of Part 6 of the *Road Transport (General) Regulation 2013*” from rule 206(1), note 3.

Insert instead “The *Road Transport (General) Regulation 2021*, Part 7.”.

[17] Rule 206(2–2), definition of “interstate or overseas authority”

Omit “Division 2 of Part 6 of the *Road Transport (General) Regulation 2013*”.

Insert instead “the *Road Transport (General) Regulation 2021*, Part 7”.

[18] Rule 207

Omit the rule. Insert instead—

207 Parking where fees are payable

- (1) This rule applies to a driver who parks on a length of road, or in an area, to which a *permissive parking sign* applies if information on or with the sign indicating a fee is payable for parking.

Note. *With* is defined in the Dictionary.

- (2) The driver must—

- (a) pay the fee, if any, payable under the law of this jurisdiction, and
- (b) obey the instructions, if any—
- (i) on or with the sign or a meter, ticket or ticket-vending machine, and
- (ii) in a mobile app or other electronic method used for the payment of fees under this rule, being an app or method indicated on or with the sign or a meter, ticket or ticket-vending machine.

Maximum penalty—20 penalty units.

- (2–1) Subrule (2) does not apply to the driver of a vehicle displaying a mobility parking scheme authority if—

- (a) the authority is in force, and
- (b) the conditions of the authority are complied with, and
- (c) the vehicle is parked in accordance with rule 206.

- (2–2) In this rule, if information in or with a *permissive parking sign* includes the words “METER”, “TICKET”, “COUPON” or “PHONE”, the information is taken to indicate a fee is payable for parking.

Note 1. *Mobility parking scheme authority* is defined in the Dictionary.

Note 2. The *Road Transport (General) Regulation 2021*, Part 6 makes provision for the administration of pay parking schemes, including the designation of pay parking areas and the fixing of fees by parking authorities.

Note 3. Subrules (2–1) and (2–2) are additional NSW subrules. There are no corresponding subrules in rule 207 of the *Australian Road Rules*.

[19] Rules 207–1 to 207–6, 207–8 and 207–9

Omit the rules.

[20] Rule 207–7 NSW rule: parking in temporarily closed pay parking areas and spaces

Omit “the *Road Transport (General) Regulation 2013*”.

Insert instead “the *Road Transport (General) Regulation 2021*”.

public consultation draft

Road Transport (General) Regulation 2021 [NSW]
Schedule 7 Amendment of other legislation

[21] Rule 207–7, note 2

Omit “Clauses 65, 72, 77 and 81 of the *Road Transport (General) Regulation 2013* enable”.
Insert instead “The *Road Transport (General) Regulation 2021*, clause 90 enables”.

[22] Rule 211 Parking in parking bays

Omit rule 211(3–1) and note 1.

[23] Rule 211, note 2

Omit “Rules 207–1 to 207–9 make provision for parking in pay parking areas.”.

[24] Rule 218–1 NSW rule: using lights on vehicles generally

Omit “clause 25 of the *Road Transport (General) Regulation 2013*” from rule 218–1(d)(ii).
Insert instead “the *Road Transport (General) Regulation 2021*, clause 18”.

[25] Rule 221–1 NSW rule: using crimson flashing warning lights on certain local council vehicles

Omit rule 221–1(2), definition of *excess weight limits legislation*, paragraph (b).
Insert instead—

(b) the *Road Transport (General) Regulation 2021*, Part 4 and clause 163.

[26] Rule 222–2 NSW rule: using warning systems for buses carrying school children

Omit “clause 25 of the *Road Transport (General) Regulation 2013*” and “Clause 25 of the *Road Transport (General) Regulation 2013*” wherever occurring.
Insert instead “the *Road Transport (General) Regulation 2021*, clause 18” and “The *Road Transport (General) Regulation 2021*, clause 18” respectively.

[27] Rule 234 Crossing a road on or near a crossing for pedestrians

Omit “Division 5 (Child safety) of Part 3 of the *Road Transport (General) Regulation 2013*” from rule 234(3)(a).
Insert instead “the *Road Transport (General) Regulation 2021*, Part 2, Division 5 (Child safety)”.

[28] Rule 234(3), note 2

Omit “Division 5 (Child safety) of Part 3 of the *Road Transport (General) Regulation 2013*”.
Insert instead “The *Road Transport (General) Regulation 2021*, Part 2, Division 5 (Child safety)”.

[29] Rule 292A Australian Road Rule not reproduced

Omit “clause 50R of the *Road Transport (General) Regulation 2013*” from rule 292A, note.
Insert instead “the *Road Transport (General) Regulation 2021*, clause 66”.

[30] Rule 300–2 NSW rule: carriage of dangerous goods in prohibited areas

Omit “clause 18(2) of the *Road Transport (General) Regulation 2013*” from rule 300–2(2)(a)(i).
Insert instead “the *Road Transport (General) Regulation 2021*, clause 11(3)”.

[31] Rule 300–4 NSW rule: school bus signs for school buses

Omit “clause 24(2) of the *Road Transport (General) Regulation 2013*” and “Clause 24 of the *Road Transport (General) Regulation 2013*” wherever occurring.

Insert instead “the *Road Transport (General) Regulation 2021*, clause 17(2)” and “The *Road Transport (General) Regulation 2021*, clause 17” respectively.

[32] Rule 307–3 NSW rule: Exemption for relevant government officer

Omit the following from rule 307–3(3)—

- rule 179–1 NSW Rule: stopping in ticket-operated loading zone
- rule 207–1 NSW rule: parking in metered parking areas
- rule 207–2 NSW rule: parking in metered parking spaces
- rule 207–3 NSW rule: parking in ticket parking areas
- rule 207–4 NSW rule: parking in ticket parking spaces
- rule 207–5 NSW rule: parking in coupon parking areas
- rule 207–6 NSW rule: parking in coupon parking spaces
- rule 207–8 NSW rule: parking in phone parking areas
- rule 207–9 NSW rule: parking in phone parking spaces

Insert in appropriate order in rule 307–3(3)—

- rule 179–1 NSW Rule: stopping in controlled loading zone

[33] Rule 313–1 NSW rule: exemptions for cash in transit vehicle drivers and escort vehicle drivers

Omit the following from rule 313–1(3), table, Column 1—

rule 179–1 (NSW Rule: stopping in ticket-operated loading zone)

rule 207–1 (NSW rule: parking in metered parking areas)

rule 207–2 (NSW rule: parking in metered parking spaces)

rule 207–3 (NSW rule: parking in ticket parking areas)

rule 207–4 (NSW rule: parking in ticket parking spaces)

rule 207–5 (NSW rule: parking in coupon parking areas)

rule 207–6 (NSW rule: parking in coupon parking spaces)

rule 207–8 (NSW rule: parking in phone parking areas)

rule 207–9 (NSW rule: parking in phone parking spaces)

Insert in appropriate order in rule 313–1(3), table, Column 1—

- rule 179–1 (NSW Rule: stopping in controlled loading zone)

[34] Rule 318 Limited effect of certain traffic control devices

Omit rule 318(2–1)(b) and (c). Insert instead—

- (b) is parked in a space located in a permissive parking area specified in the permit and the area is designated by the parking authority for use by the holder of the permit.

[35] Rule 318(2–1), note 1

Omit “and *printed parking permit* are”. Insert instead “is”.

[36] Rule 318(4), definition of “permissive parking area”

Omit “clause 95 of the *Road Transport (General) Regulation 2013*”.

Insert instead “the *Road Transport (General) Regulation 2021*, clause 120”.

[37] Dictionary

Omit the following definitions—

coupon parking area

coupon parking space

electronic parking permit

metered parking area

metered parking space

ordinary metered parking area

parking coupon

parking meter

parking ticket

phone parking area

phone parking space

printed parking permit

registration metered parking area

ticket parking area

ticket parking space

ticket-operated loading zone

[38] Dictionary, definition of “controlled loading zone”

Insert in appropriate order—

controlled loading zone—see rule 179–1.

Note. This is an additional NSW definition. There is no corresponding definition in the Dictionary of the *Australian Road Rules*.

[39] Dictionary, definition of “goods vehicle”

Omit the definition. Insert instead—

goods vehicle means a vehicle constructed principally for the conveyance of goods.

Note 1. *Vehicle* is defined in rule 15.

Note 2. This is an additional NSW definition. There is no corresponding definition in the Dictionary of the *Australian Road Rules*.

[40] Dictionary, definition of “mobility parking scheme authority”

Omit “Division 2 of Part 6 of the *Road Transport (General) Regulation 2013*”.

Insert instead “the *Road Transport (General) Regulation 2021*, Part 7, Division 2”.

[41] Dictionary, definition of “parking permit”

Omit “an electronic or printed parking permit”.

Insert instead “a parking permit issued under the *Road Transport (General) Regulation 2021*, clause 120”.

[42] Dictionary, definition of “pay parking area”

Omit the definition. Insert instead—

pay parking area has the same meaning as in the *Road Transport (General) Regulation 2021*.

[43] Dictionary, definition of “pay parking space”

Omit the definition. Insert instead—

pay parking space has the same meaning as in the *Road Transport (General) Regulation 2021*.

7.11 Road Transport (Driver Licensing) Regulation 2017

Clause 109 Release of certain photographs

Omit “clause 109(1)(d1) of the *Road Transport (General) Regulation 2013*” from note 2, paragraph (c).

Insert instead “the *Road Transport (General) Regulation 2021*, clause 112(1)(e)”.

7.12 Road Transport (Vehicle Registration) Regulation 2017

[1] Clause 74 Notification of decisions by TfNSW

Omit “clause 135 of the *Road Transport (General) Regulation 2013*” from clause 74(2)(b).

Insert instead “the *Road Transport (General) Regulation 2021*”, clause 147”.

[2] Clause 96 Service of notices under Part

Omit “Clause 7 of the *Road Transport (General) Regulation 2013*” from the note.

Insert instead “The *Road Transport (General) Regulation 2021*”, clause 155”.

[3] Clause 141, heading

Omit the heading. Insert instead—

141 Application of Road Transport (General) Regulation 2021, Part 4 and clause 163

[4] Clause 141(1)

Omit “Part 3A or clause 148 of the *Road Transport (General) Regulation 2013*”.

Insert instead “the *Road Transport (General) Regulation 2021*”, Part 4 or clause 163”.

[5] Schedule 2 Light Vehicle Standards Rules

Omit clause 114(11), definition of *excess weight limits legislation*, paragraph (b).

Insert instead—

(b) the *Road Transport (General) Regulation 2021*, Part 4 and clause 163.

Schedule 8 Dictionary

clause 3

added load, for Part 4—see clause 51.

applicable vehicle standards law means the *Road Transport (Vehicle Registration) Regulation 2017*, clause 25, and—

- (a) if the vehicle is a light vehicle—the *Light Vehicle Standards Rules*, or
- (b) if the vehicle is a heavy vehicle within the meaning of the *Heavy Vehicle National Law (NSW)*—the heavy vehicle standards within the meaning of the Law.

Note— See the *Heavy Vehicle (Vehicle Standards) National Regulation (NSW)*.

area of operations means—

- (a) for a council—the council’s local government area, and
- (b) for a declared organisation—the area of operations specified in relation to the organisation in Schedule 2, Column 2.

articulated vehicle has the same meaning as it has in the *Road Rules 2014*.

axle has the same meaning as it has in the *Road Rules 2014*.

axle group has the same meaning as it has in the *Road Rules 2014*.

axle load, for Part 4—see clause 51.

bus has the same meaning as it has in the *Road Rules 2014*.

centreline, of an axle or axle group, has the same meaning as it has in the *Road Rules 2014*.

controlled loading zone has the same meaning as it has in the *Road Rules 2014*.

corresponding heavy vehicle standard, in relation to a provision of the *Light Vehicle Standards Rules*, means a heavy vehicle standard under the *Heavy Vehicle National Law (NSW)* corresponding, or substantially corresponding, to the provision.

council means the council of a local government area.

declared organisation means a body constituted by or under an Act or a government department specified in Schedule 2, Column 1.

designated road, for Part 3—see clause 32.

disabled person means a person—

- (a) who is unable to walk because of permanent or temporary loss of the use of one or both legs or other permanent medical or physical condition, or
- (b) whose physical condition is detrimentally affected as a result of walking 100 metres, or
- (c) who requires the use of crutches, a walking frame, callipers, scooter, wheelchair or other similar mobility aid.

driver licensing law means—

- (a) the Act, Chapter 3, and
- (b) the *Road Transport (Driver Licensing) Regulation 2017*.

enforcement officer, for Part 3—see clause 32.

existing motor lorry, for Part 4, Division 2—see clause 53.

general manager, for Part 3—see clause 32.

goods vehicle has the same meaning as it has in the *Road Rules 2014*.

holder, of a scheme authority, or an expired or revoked scheme authority, under Part 7—see clause 99.

interstate or overseas authority, for Part 7—see clause 99.

Light Vehicle Standards Rules has the same meaning as it has in the *Road Transport (Vehicle Registration) Regulation 2017*.

load-carrying, for Part 4—see clause 51.

loaded mass, for Part 4—see clause 51.

loading zone device—see clause 121.

loading zone ticket—see clause 121.

mobility parking scheme, for Part 7—see clause 99.

mobility parking scheme authority or **scheme authority** means an authority issued under Part 7, Division 2.

motor bike means any motor vehicle that has 2 wheels or, if a sidecar or sidebox is attached to it, has 3 wheels and includes a motor tricycle.

motor lorry has the same meaning as it has in the *Road Rules 2014*.

motor tricycle means any motor vehicle with 3 wheels and having a GVM of 1 tonne or less.

officer-in-charge, for Part 3—see clause 32.

organisation, for Part 7—see clause 99.

park has the same meaning as it has in the *Road Rules 2014*.

parking area has the same meaning as it has in the *Road Rules 2014*.

parking authority means a council or a declared organisation.

parking bay has the same meaning as it has in the *Road Rules 2014*.

parking permit means a permit issued under clause 120.

pay parking area means a parking area designated by one or more permissive parking signs where information on or with the sign indicating a fee is payable for parking in the area, but does not include a part of the parking area in which the parking of vehicles is prohibited by another provision of the road transport legislation.

pay parking device means a device referred to in clause 84(2).

pay parking period—see clause 87.

pay parking scheme means a scheme established by a parking authority under clause 84.

pay parking space means a parking bay in a pay parking area.

permissive parking sign means a traffic sign of the kind referred to in the *Road Rules 2014*, rule 204.

prime mover has the same meaning as it has in the *Road Rules 2014*.

public passenger service has the same meaning as it has in the *Passenger Transport Act 1990*.

quad-axle group means a group of 4 axles, in which the horizontal distance between the centrelines of the outermost axles is more than 3.2 metres but not more than 4.9 metres.

registry has the same meaning as it has in the *Road Transport (Vehicle Registration) Regulation 2017*.

regular passenger service has the same meaning as it has in the *Passenger Transport Act 1990*.

relevant parking fee, in relation to the parking of a vehicle in a pay parking space or area, means the fee for parking a vehicle in the space or area, for the day and time during which the vehicle is parked in the space or area, that is—

- (a) fixed by the parking authority, and
- (b) displayed in the pay parking area, or on a pay parking device for the space or area.

road—see clause 3(2).

road related area—see clause 3(2).

school zone means a school zone as defined in the *Road Rules 2014*, rule 23(2), but only during the period in which the speed limit indicated by a school zone sign has effect, as referred to in those Rules, rule 318(3–1).

semi-trailer has the same meaning as it has in the *Road Rules 2014*.

sidecar has the same meaning as it has in the *Road Rules 2014*.

single axle has the same meaning as it has in the *Road Rules 2014*.

special event parking area has the same meaning as it has in the *Road Rules 2014*, rule 205A–1.

station wagon has the same meaning as it has in the *Road Transport (Vehicle Registration) Regulation 2017*.

tandem axle group has the same meaning as it has in the *Road Rules 2014*.

TfNSW guidelines means guidelines issued by Transport for NSW in force—

- (a) for a pay parking scheme—under clause 93(1), and
- (b) for the issue of parking permits—under clause 120(3), and
- (c) for a controlled loading zone scheme—under clause 126(1).

the Act means the *Road Transport Act 2013*.

total mass, for Part 4—see clause 51.

traffic sign has the same meaning as it has in the *Road Rules 2014*.

tri-axle group has the same meaning as it has in the *Road Rules 2014*.

vehicle—

- (a) for Part 4—see clause 51, and
- (b) for Part 6 and Part 8, includes a horse.

visiting motor lorry, for Part 4, Division 2—see clause 53.

wheel, for Part 4—see clause 51.