



Transport
Roads & Maritime
Services

TECHNICAL GUIDELINE

Temporary stormwater drainage for road construction

DECEMBER 2011



About this release

ISBN	978-1-922040-25-1
RMS Document number	11.068
Guideline title	Temporary stormwater drainage for road construction
Author	Environment Branch (Environmental Policy)

Issue	Date	Revision description
1	June 2011	Draft
2	November 2011	Final draft
3	December 2011	Final

COPYRIGHT

© NSW Roads and Maritime Services, 2011

All intellectual property and copyright reserved.

Apart from any fair dealing for the purpose of private study, research, criticism or review, as permitted under the Copyright Act, 1968, no part of this report may be reproduced, transmitted, stored in a retrieval system or adapted in any form or by any means (electronic, mechanical, photocopying, recording or otherwise) without written permission.

CONTENTS

ABOUT THIS RELEASE.....	I
1 PURPOSE.....	1
2 SCOPE.....	1
3 INTRODUCTION.....	1
4 BACKGROUND.....	2
4.1 DEFINITIONS.....	2
4.2 ACHIEVING SUCCESS THROUGH EARLY INSTALLATION OF PERMANENT DRAINAGE CONTROLS	2
4.3 GENERAL PRINCIPLES OF EROSION AND SEDIMENT CONTROL	2
4.4 TEMPORARY CROSS-DRAINAGE: KEY PRINCIPLES.....	3
4.5 USING THIS GUIDELINE	3
5 NEW CULVERT CONSTRUCTION.....	5
5.1 INTRODUCTION	5
5.2 APPLICATIONS	5
5.3 PREFERRED METHODS FOR TEMPORARY DIVERSION	5
5.4 PLANNING, DESIGN AND CONSTRUCTION CONSIDERATIONS	6
6 CULVERT EXTENSION OR REPLACEMENT	9
6.1 INTRODUCTION	9
6.2 APPLICATIONS	9
6.3 PLANNING, DESIGN AND CONSTRUCTION CONSIDERATIONS	9
7 UPSTREAM DIVERSION AND CROSS-DRAINAGE OF OFFSITE WATER	13
7.1 INTRODUCTION	13
7.2 APPLICATIONS	13
7.3 PLANNING, DESIGN AND CONSTRUCTION CONSIDERATIONS	13
8 MANAGEMENT OF ONSITE WATER	16
8.1 INTRODUCTION	16
8.2 APPLICATIONS	16
8.3 PLANNING, DESIGN AND CONSTRUCTION CONSIDERATIONS	16
9 SEPARATION OF ONSITE AND OFFSITE WATER ON BATTER BERMS AND AT CUT/FILL INTERFACE	20
9.1 INTRODUCTION	20
9.2 APPLICATIONS	20
9.3 PLANNING, DESIGN AND CONSTRUCTION CONSIDERATIONS	20
10 REFERENCES.....	22
11 APPENDICES.....	23
APPENDIX 1: ACKNOWLEDGEMENTS.....	23
APPENDIX 2: BLUE BOOK STANDARD DRAWINGS	24
APPENDIX 3: PUMP REQUIREMENTS.....	30
APPENDIX 4: DRAWINGS & DIAGRAMS.....	31

1 PURPOSE

The purpose of this Guideline is to provide design considerations and example drawings to assist Roads and Maritime Services (RMS) and contractor project management teams to plan and design for temporary stormwater drainage on RMS construction sites. It is intended that use of this Guideline will support improved environmental performance and efficient construction delivery.

2 SCOPE

This Guideline is a technical reference and has been prepared to assist concept and detailed design and project delivery. This Guideline applies to all main road construction projects. The design advice and example drawings may be used to prepare site-specific solutions to complex temporary drainage issues. The use of innovation is encouraged to provide effective temporary drainage that prevents pollution of the environment.

3 INTRODUCTION

Soil and water management is a critical compliance risk for all RMS construction projects. Effective soil and water management includes a range of principles, however the key elements that must be considered for temporary drainage on all sites include:

- Separation of 'offsite' and 'onsite' water at all times;
- Maintaining the quality of all 'offsite' water and passing it through or around works areas without picking up additional sediment;
- Ensuring that sediment-laden runoff from works areas is effectively transferred to and treated by control measures (eg sedimentation basins).

It is RMS's expectation that 'offsite' stormwater diversion, and cross-drainage through or around exposed construction areas will be achieved. If temporary stormwater drainage is not effectively implemented on main road construction sites it may compromise the overall effectiveness of the erosion and sediment control strategy, and result in potential compliance risks.

Effective stormwater management during construction relies on due consideration of design constraints and issues at the concept planning and design stages of project development. Constraints to the effective installation of temporary cross-drainage should be identified as early as possible in project development so alternative strategies can be designed to meet the project objectives. This approach is consistent with the *RTA Erosion and Sedimentation Management Procedure, 2009*.

This Guideline also identifies how external factors (eg permanent drainage design, land availability or conflicting constraints such as heritage or vegetation) may impact on temporary stormwater management during construction. By providing design and implementation principles and a series of example drawings, this Guideline aims to facilitate better environmental performance for road construction projects in NSW.

4 BACKGROUND

4.1 Definitions

For the purpose of this Guideline, 'offsite' and 'onsite' water are defined as follows:

Offsite water	Any water that enters the site from external lands; OR Any water that lands within the site but does not make contact with exposed soil or other onsite water. Colloquially referred to as 'clean water' on many sites.
Onsite water	Any water that makes contact with exposed soil within the site. Colloquially referred to as 'dirty water' on many sites.

4.2 Achieving success through early installation of permanent drainage controls

This Guideline principally deals with the installation of temporary stormwater diversions only, not permanent drainage works. However, in many cases the **successful implementation of temporary cross-drainage relies on early and effective installation of permanent drainage.**

By installing permanent drainage such as pipes and culverts as 'early works' (ie prior to any other road construction, clearing or earthworks taking place), 'offsite' water from upslope of the alignment can be transferred to the downslope side more easily and with reduced risk of it becoming contaminated with sediment from onsite.

Early installation of permanent cross-drainage structures will generally benefit environmental outcomes and also assist efficient construction by keeping the site drier. 'Offsite' waters are kept away from construction areas, improving constructability and access.

- Wherever possible, plan to construct culverts as early works. Fill can then be compacted over the culvert to allow movement of earthworks vehicles.
- Wherever possible, construction-stage sediment basins should be constructed as early works and before clearing or stripping occur.

4.3 General principles of erosion and sediment control

General principles for erosion and sediment control are detailed in existing best-practice publications such as Landcom (2004) and DECC (2008) (Volumes 1 and 2D of 'Managing Urban Stormwater – Soils and Construction' or the 'Blue Book'). As such, they are not detailed here, but can be summarised as follows:

- Assess constraints to erosion and sediment control prior to works commencing.
- Plan for erosion and sediment control prior to works commencing.
- Minimise the extent and time of disturbance.
- Manage soils (particularly topsoils) well.

- Control water on, through and from the site. This includes providing adequate sediment-retention structures.
- Maximise sediment retention, filtration and / or settling onsite.
- Stabilise and rehabilitate areas progressively and quickly.
- Inspect and maintain erosion and sediment control measures as required.

Effective temporary cross-drainage on major road projects relies on the above principles being implemented. This manual provides guidance on specific issues related to the above principles where necessary.

4.4 Temporary cross-drainage: key principles

The key principles that apply to temporary cross-drainage on main road construction sites are:

- Transfer 'offsite' water across the site/project without it becoming contaminated with sediment from onsite.
- Avoid mixing 'offsite' water with 'onsite' water.
- Ensure that 'onsite' water is conveyed to an appropriate sediment retention structure (eg sediment basin, sediment fence) prior to release.
- All channelised flowpaths, whether natural or constructed, should be lined. This includes batter berms. Lining materials should be appropriate for use in channel-flow conditions and should provide protection from erosion in both the short and long term.

These key principles need to be considered at all stages of project planning, design and construction.

4.5 Using this guideline

RMS is committed to improved environmental performance on road construction projects. This Guideline has been developed to provide design tools to assist in meeting this objective. The design tools are presented in five separate chapters, being:

- New Culvert Construction (Ch. 5)
- Culvert Extension or Replacement (Ch. 6)
- Upstream Diversion and Cross-Drainage of Offsite Water (Ch. 7)
- Management of Onsite Water (Ch. 8), and
- Separation of Onsite and Offsite Water on Batter Slopes and at Cut/Fill Interface (Ch. 9).

This Guideline is intended for use by all RMS and Contractor staff that are involved in the planning, design, implementation and monitoring of temporary drainage controls on RMS road construction projects. This Guideline supports established erosion and sedimentation control guidelines including Landcom (2004) and DECC (2008) (Volumes 1 and 2D of 'Managing Urban Stormwater – Soils and Construction' or the 'Blue Book').

RMS encourages the preliminary design and assessment of constraints for implementation of major erosion and sedimentation control including temporary stormwater diversions and cross-drainage. This is emphasised in the *RTA Erosion and Sedimentation Management Procedure*,

1999, which requires preliminary design of temporary cross-drainage for all high risk projects. This Guideline should be used to support preliminary and detailed design to ensure that effective designs are prepared for implementation on all construction projects.

It is intended that the example drawings presented in this guideline will be used to form the basis for the temporary drainage component of erosion and sedimentation control plans. For example, the drawings for culvert extension and replacement works in Chapter 6 can be modified with site-specific requirements and used as a plan for works.

Areas of construction sites with temporary drainage controls may be subject to periodic stormwater inundation or flooding with infiltrated groundwater. The *RTA Technical Guideline for Environmental Management of Construction Site Dewatering, 2011*, should be used as a reference to prepare site dewatering work method statements to manage dewatering activities.

5 NEW CULVERT CONSTRUCTION

5.1 Introduction

Several scenarios are presented in this chapter, applying to both new 'online' and 'offline' culverts. The primary aim of the scenarios is the safe passage of 'offsite' water in a drainage line across the alignment and around/through culvert works areas.

Refer to Drawings 1, 2, 8, 10 & 11 in Appendix 4 for typical scenarios and technical guidance.

Effective cross-drainage during construction often relies on the early installation of major culvert crossings to provide cross-drainage of 'offsite' water during major earthworks stages.

5.2 Applications

The typical scenarios presented in this chapter apply to:

- Greenfield construction sites (e.g. highway bypass projects).
- Duplication or realignment projects where sufficient space is available between carriageways to permit diversion of natural drainage lines.
- Culvert replacement projects, providing traffic switching does not interfere with space requirements for diverting natural flows.

5.3 Preferred methods for temporary diversion

Preferred methods of temporary diversion for culvert construction projects are those that provide direct drainage diversion through temporary channels or temporary pipes and a second preference. These methods allow for confidence in the temporary diversion at times when the site is not supervised and do not rely on equipment such as pumps for success.

For all sites, temporary groundcover should be applied to all exposed soils in the worksite when the temporary controls may overtop, resulting in stormwater flow directly through the work site. This may be where a significant rainfall or flow event is forecast or where the site is left unattended for prolonged periods.

Pumping options are not preferred. This chapter presents a pumping option that may be applied only for pipe replacement/installation where the works are in small channels with intermittent flows with a construction period of no more than three months. Pumping options present higher risks when sites are not supervised or in periods of prolonged heavy rainfall, where a pump failure would result in stormwater flow directly through the work site. Particular attention must be made to providing temporary site cover on sites using a pump option. Recommended flow rates for pumps are detailed in Appendix 3.

5.4 Planning, design and construction considerations

1. During concept and detailed design, investigate the nature of the waterway to determine the most appropriate method for temporary 'offsite' water cross-drainage during construction. This requires an investigation of:
 - a. Perennial or intermittent flow.
 - b. Width, channel form, depth.
 - c. Surrounding topography.
 - d. Soils in the culvert to determine amount of unsuitable material (ie. will excavations require benching?).
2. Offline culverts generally involve less land disturbance and present a lower erosion hazard during construction than online culverts.
3. Culverts requiring temporary side channels for construction may not be feasible in steep country or for deeply-incised drainage lines. In such cases, alternatives including bridges should be considered.
4. Sufficient land needs to be provided for earthworks and inlet/outlet protection at the edge of culvert extensions.
5. Do not commence construction of permanent culverts until 'offsite' water flows have been successfully diverted/managed.
6. If a temporary channel is to be used, ensure sufficient space is provided on either side of the proposed carriageway to allow for temporary diversion of the watercourse. This must include the space for construction of the bund walls of the temporary channel and the bund batters. Sheet piling, pipes, rock or sandbag walls might be required where space is limited (or an alternative method sought).
7. Temporary channels should be constructed with minimal freeboard above the design flow level so that excess flows can spill into the culvert works area in high flow events. This minimises the risk of upstream flooding.
8. If possible, the inlet/outlet scour protection into and out of the temporary channels should double as part of the long-term operational scour protection for the operational culvert.
9. Where diversion bunds or temporary/sacrificial pipes will be used, ensure they are stabilised and operating effectively before depressions are filled.
10. Include seepage collars on temporary or sacrificial pipes.
11. If water will pond against the fill on the upslope side of a small depression, use temporary lining materials (eg. geofabric) to ensure ponded water does not contact any exposed soil.



Plate 1 - Temporary creek diversion during construction of an online culvert, Pacific Highway Coopernook to Herons Creek project.



Plate 2 - Use of sheet piling to divert 'offsite' flows between new and old culverts. This level of control might be necessary where space is limited.



Plate 3 - Extremely space-constrained scenario where the new culvert is at a differing alignment to the existing, with insufficient space between carriageways to effectively divert flows.



Plate 4 - Temporary pipe to convey 'offsite' water around culvert works area. While this is a suitable solution for temporary cross-drainage there is a significant risk of contamination of 'offsite' water due to lack of erosion and sediment controls around the pipe and channel.

6 CULVERT EXTENSION OR REPLACEMENT

6.1 Introduction

Several scenarios are presented in this chapter for online culvert extension or replacement. In these scenarios, diversion of 'offsite' water around the worksite is normally not possible. However, the primary aim in all of the scenarios presented here is the safe passage of 'offsite' water without it becoming contaminated with sediment from onsite.

Refer to Drawings 3, 4, 5, 10 & 11 in Appendix 4 for typical scenarios and technical guidance. Note these are not exhaustive and provide example solutions which can be modified for specific site application.

6.2 Applications

The typical scenarios presented in this chapter apply to:

- Online culvert extensions.
- Online culvert replacement.
- Temporary use and extension of existing culverts during construction.

6.3 Planning, design and construction considerations

1. Where natural drainage lines are subject to perennial flows, or significant intermittent flow, care should be taken with any scenario that involves temporarily reducing or restricting the effective flowpath (eg. partial blocking of a multiple-cell culvert).
2. Assess the feasibility of using old structures (or part thereof) to provide a protected flow path for temporary cross-drainage.
3. Consideration should be given to the amount of material that will need to be removed from the works area. Where significant amounts of unsuitable material occurs, benching might be required during excavations, effectively extending the amount of time required for earthworks. Passage of 'offsite' water needs to be considered for the full amount of time that earthworks will occur.
4. Sufficient room needs to be provided for earthworks and inlet/outlet protection at the edge of the extended culvert.
5. Management regimes should be included to rapidly cover exposed soils if an unexpected rain event occurs during earthworks.
6. Undertake works only when significant rain is not forecast during the expected works period. An accurate and realistic timeframe should be estimated and the rainfall forecast investigated for that period.

7. Partial blocking of multiple-cell culverts should only be to a maximum of half the culvert cell height.
8. Where partial blocking of multiple-cell culverts is used, works can only proceed on the blocked portions.
9. Partial-cell blocking might not be feasible where deep excavations and benching are required.
10. Where pumps are proposed for transfer of off-site water, recommended flow rates for pumps are detailed in Appendix 3.



Plate 5 - Extension of an existing seven-box culvert for construction of an additional carriageway, Northern Hume Alliance project. Bunding is required at the edge of the concrete pad to keep 'offsite' water out of the works area.



Plate 6 - Temporary pipe inside new, extended culvert to convey 'offsite' water through the works area until culvert (including rock-lined outlet) is complete.



Plate 7 - Use of a half-height partial block of a multiple-cell culvert during culvert extension works.



Plate 8 - Temporary extension of existing pipe to allow for placement of fill on new carriageway adjacent to existing. Note the seal around pipe joint to prevent sediment ingress.



Plate 9 - Water flowing into excavation for an online culvert extension – needs to be treated prior to discharge. Diversion of ‘offsite’ flows is preferable.



Plate 10 – Replacement of part of an existing culvert, with offsite water temporarily managed through a sandbagged channel on the old base slab.

7 UPSTREAM DIVERSION AND CROSS-DRAINAGE OF OFFSITE WATER

7.1 Introduction

Cross-drainage of offsite water relies on early installation of culverts and effective lined drains on the uphill side of the alignment.

Refer to Drawings 6, 7, 8 & 9 in Appendix 4 for typical scenarios and technical guidance. Note these are not exhaustive and are intended to provide guidance for site-specific solutions.

7.2 Applications

The typical scenarios presented in this chapter apply to:

- All sites.

7.3 Planning, design and construction considerations

1. Wherever possible, plan to construct cut-off drains above cut batters as early works. Note that these might not be able to be completely constructed at this stage; temporary sections might be required to convey flows from the cut/fill line down to natural watercourses so adequate space can be provided for sediment basins.
2. Offsite water drains must be lined, stabilised and cleaned of any sediments.
3. Clearing limits need to include an allowance for diversion of 'offsite' water from upslope.
4. Ensure that sufficient land is made available to accommodate temporary drains where required.
5. Where water would need to be conveyed long distances from its pick-up point to a feasible outlet, consider the potential to include an alternative outlet (eg. additional drainage) within the cut section.
6. If it is not feasible to drain 'offsite' water out of complex cuts via gravity, pumps may be required. Refer to Appendix 3 for recommended pump flow capacities.
7. An open chute or flume can be used to drain 'offsite' water down batters and through the works area if required. However, this structure must be lined so it is protected from erosion. Note there is a significant risk that 'onsite' site water could flow into an open structure, so it is preferable to use pipes.
8. Temporary pipes can be flexible if desired and moved around, providing constant fall is achieved along the pipe.

9. Ensure that any temporary or sacrificial pipes are sized according to the designs. This should be to convey flows as nominated in Table 6.1 of DECC, 2008. Do not substitute a different sized pipe without consulting the design engineer.
10. Outlet discharge must be onto a stable dissipater. If possible, outlet temporary and sacrificial pipes onto the same dissipater that will be used for permanent drainage outlet structures. This minimises in-stream works.
11. Use caution when specifying the use of pumps for cross-drainage. All associated problems if pumps were to fail must be considered and addressed. Pumps should only be used as a last resort.
12. Preferably, pumps should not be relied upon for cross-drainage where a public safety risk exists should the pump not be activated (e.g. water pooling onto a public road). If, however, pumps are used the recommended flow rates for pumps are detailed in Appendix 3.
13. Ensure management regimes are included to ensure that pumps, if included, are switched on when required.



Plate 11 - 'Offsite' water in the cut-off drain and upslope depression is spilling onto a piece of black plastic, then into the works area. Temporary cross-drainage should be provided to prevent this scenario.



Plate 12 - Lined drain on the high side of the alignment to manage 'offsite' water.



Plate 13 - Early installation and stabilisation of diversion drain for 'offsite' water.

8 MANAGEMENT OF ONSITE WATER

8.1 Introduction

Management of 'onsite' water is assisted when 'offsite' water is effectively managed and does not contribute to 'onsite' stormwater volumes. 'Onsite' water should not be discharged from site untreated.

Refer to Drawings 6, 7 & 9 in Appendix 4 for typical scenarios and technical guidance. Note these are not exhaustive and are intended to provide guidance for site-specific solutions.

8.2 Applications

The typical scenarios presented in this chapter apply to:

- All sites.

8.3 Planning, design and construction considerations

1. All 'onsite' water should be directed to a sediment retention structure (preferably a sediment basin).
2. Structures to manage sediment in 'onsite' water should be in place prior to stripping topsoil. Sediment basins should be included in the construction program as early works.
3. Temporary drains to direct 'onsite' water to sediment retention structures (eg. basins) should be lined. Unlined drains (or edges of formation) will pose a significant gully erosion risk.
4. Ensure that check dams in temporary drains will not cause water to back up and exit the drain. Sediment fence is not recommended for use in channelised flows.
5. Turn-outs, or mitre drains might be required in places to direct 'onsite' water to sediment retention structures (eg. basins).
6. Wherever possible, camber the cut/fill to facilitate drainage to sediment retention structures. Ideally, these should have been placed to work with the anticipated road camber.
7. Temporary drains should be used when rain is imminent to ensure 'onsite' water is directed to sediment retention structures and to reduce the slope length on long, exposed formation slopes.
8. An earth windrow or bund should be maintained at the top of fills to prevent flow of water over fill batters, with regular exit points for water onto lined batter chutes.



Plate 14 - Lined batter chutes to minimise erosion on a fill batter and to control flows.



Plate 15 - Earth windrows at the edge of fills to control the exit of 'onsite' water down the fill batters to sediment retention structures.



Plate 16 - Turn-out (mitre) drain to exit 'onsite' water to a sediment basin.



Plate 17 - Unlined drain at edge of formation showing significant erosion despite regular sandbag check dams. Lining of this drain would prevent erosion.



Plate 18 - Temporary cut drain across the formation to direct 'onsite' runoff to a sediment basin. Cut drains should also be used to break up a catchment into smaller erosive slopes when rain is imminent or during periods of site closure.

9 SEPARATION OF ONSITE AND OFFSITE WATER ON BATTER BERMS AND AT CUT/FILL INTERFACE

9.1 Introduction

Large cut batters often incorporate berms (including berm drains) to divert runoff away laterally. During construction, these berm drains convey 'onsite' runoff until their upslope catchment is stabilised/rehabilitated. However, they often present problems for mixing of 'onsite' and 'offsite' water.

Similarly, 'onsite' water is often directed off the formation at the cut/fill interface, where it can mix with 'offsite' water if adequate temporary drainage is not provided.

Refer to Drawings 7 & 9 in Appendix 4 for typical scenarios and technical guidance. Note these are not exhaustive and are intended to provide guidance for site-specific solutions.

9.2 Applications

The typical scenarios presented in this chapter apply to:

- All sites.

9.3 Planning, design and construction considerations

1. Progressive stabilisation of batters is essential and should be planned for as earthworks proceed. Each section of the batter should be shaped, topsoiled and rehabilitated before proceeding to the next section.
2. Failure to progressively stabilise batters means that temporary diversion of 'onsite' runoff in the berm drain must be conveyed over lower sections of the batter (note risk of erosion) or in a temporary chute and onto the works area.
3. Check structures made of straw bales, aggregate bags, sediment fence or rock are not sufficient to remove sediment from 'onsite' water flowing in berm drains – this water should generally be directed to a sediment basin.
4. Temporary diversion bunds will be required to disconnect flows in berm drains from the 'offsite' water cut-off drains.
5. Until the batter areas above berm drains are topsoiled, stabilised and rehabilitated, berm drains must remain disconnected from the cut-off drains.
6. Inspect berm drain disconnection measures regularly to ensure they are intact, functional and not eroding or causing erosion. Repair any existing or potential problems immediately.
7. Temporary separation of 'onsite' and 'offsite' water at the cut/fill line and below should be planned for and adequate space provided.



Plate 19 - Progressive stabilisation of a cut batter above a berm drain. Flows in the berm drain should remain disconnected from the cut-off drain behind the cut face until the batter face is rehabilitated.



Plate 20 - Example showing offsite (clean) and onsite (dirty) water mixing at the cut/fill line. Offsite run-on should be temporarily diverted as shown using a berm, drain or sandbags so it doesn't flow to the sediment basin.

10 REFERENCES

Department of Environment and Climate Change (DECC) (2008). *Managing Urban Stormwater: Soils and Construction. Volume 2D: Main Road Construction*. NSW DECC, Sydney.

<http://www.environment.nsw.gov.au/resources/stormwater/08207soilsconststorm2d.pdf>

Landcom (2004). *Managing Urban Stormwater: Soils and Construction. Volume 1*. 4th Edition. NSW Landcom, Sydney.

<http://home.rta.nsw.gov.au/org/directoratesandbranches/env/documents/managingurbanstormwater.pdf>

NSW Roads and Traffic Authority (2009). *RTA Erosion and Sedimentation Management Procedure*. NSW Roads and Maritime Services, Sydney.

<http://home.rta.nsw.gov.au/dts/cserv/os/original/environment/pn143p.pdf>

NSW Roads and Traffic Authority (2011). *RTA Technical Guideline – Environmental Management of Construction Site Dewatering*. EMS-TG-001. NSW Roads and Maritime Services, Sydney.

<http://home.rta.nsw.gov.au/dts/cserv/os/original/environment/ems-tg-11.doc>

11 APPENDICES

Appendix 1: Acknowledgements

All photographs were provided by Andrew Macleod from Strategic Environmental & Engineering Consulting.

Thank you to the following people, who provided their time and expertise to assist in the production of this document:

Andrew Macleod – Strategic Environmental & Engineering Consulting – Preliminary guideline drafting, preparation of example drawings and field consultation

Simon Hooper, Northern Hume Alliance
David Thompson, NSW Soil Conservation Service
Angela Riepsamen, NSW RMS, Southern Region
John Wright, Southern Hume Alliance
Adrian Rouse, NSW RMS Southern Region
Tracey Doczy, Coopernook to Herons Creek Alliance
Erin Woodward, Coopernook to Herons Creek Alliance
Phil Rowan, Coopernook to Herons Creek Alliance
Matt Parkinson, Coopernook to Herons Creek Alliance
Robert Rich, Coopernook to Herons Creek Alliance
Jenny Butler, Southern Hume Alliance
Matt Boyd, Southern Hume Alliance
Greg Court, Southern Hume Alliance
Andrew Cook, NSW RMS
Jason Hand, Northern Hume Alliance
Ben Robilliard, Northern Hume Alliance
Kenzie Cochrane, Northern Hume Alliance
Joseph Fanous, NSW RMS
Peter Ellis, NSW RMS
Brad Hartley, NSW RMS
Erica Adamson, NSW RMS Environment Branch
Chris Blake, NSW RMS Environment Branch

Appendix 2: Blue Book Standard Drawings

A number of Standard Drawings from Landcom (2004) are referred to in this document, either directly or indirectly. These are appended here:

- Standard Drawing SD 5-1 (Temporary Waterway Crossings)
- Standard Drawing SD 5-5 (Low-Flow Earth Banks)
- Standard Drawing SD 5-6 (High-Flow Earth Banks)
- Standard Drawing SD 5-8 (Energy Dissipaters)
- Standard Drawing SD 6-8 (Sediment Fence)

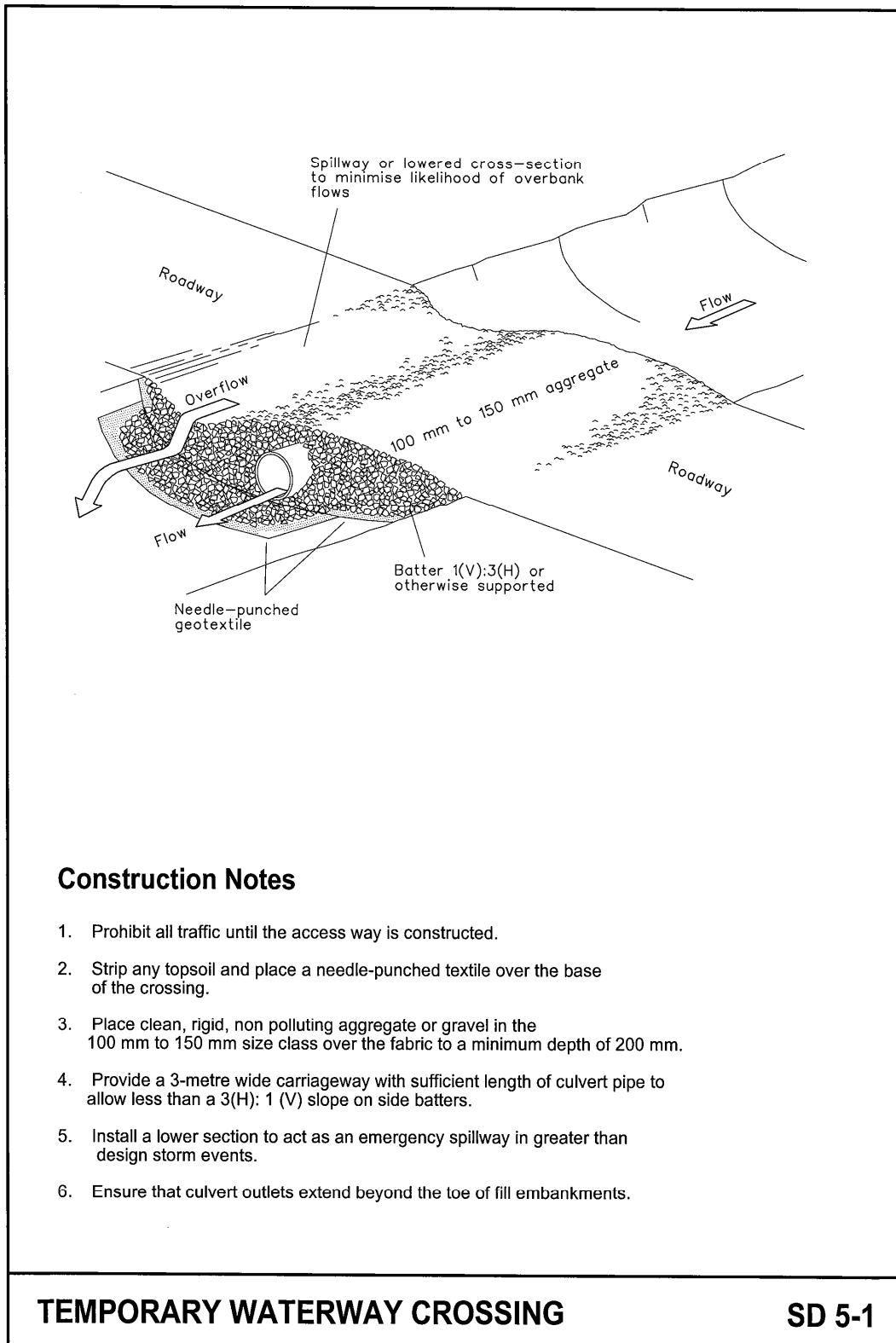

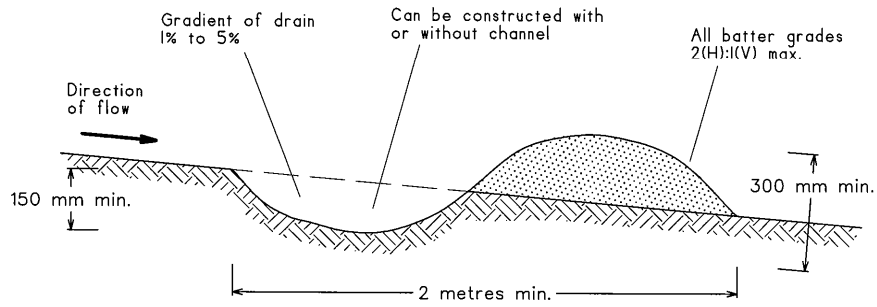

NOTE: Only to be used as temporary bank where maximum upslope length is 80 metres.

Construction Notes

1. Build with gradients between 1 percent and 5 percent.
2. Avoid removing trees and shrubs if possible - work around them.
3. Ensure the structures are free of projections or other irregularities that could impede water flow.
4. Build the drains with circular, parabolic or trapezoidal cross sections, not V shaped.
5. Ensure the banks are properly compacted to prevent failure.
6. Complete permanent or temporary stabilisation within 10 days of construction.

EARTH BANK (LOW FLOW)

SD 5-5

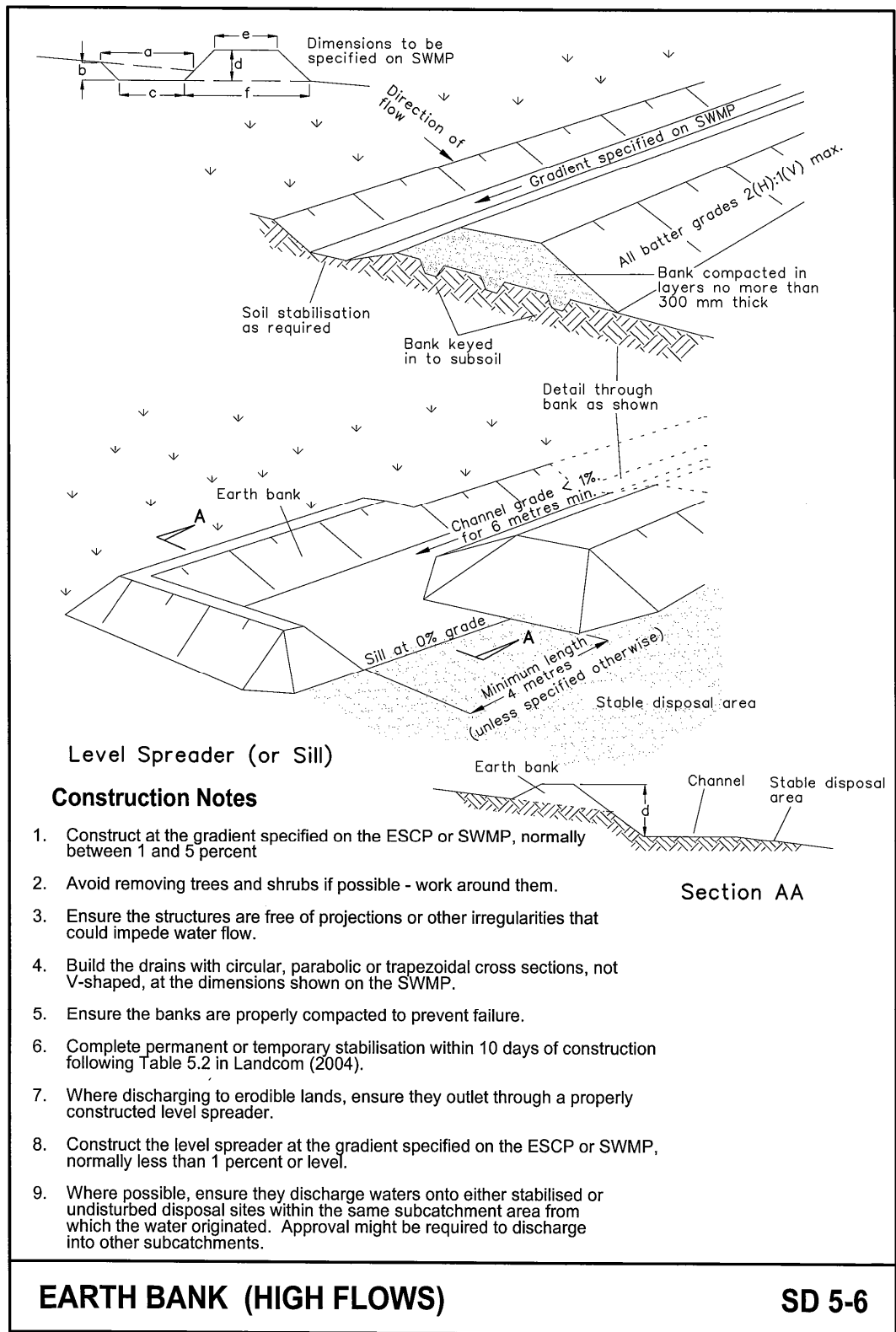

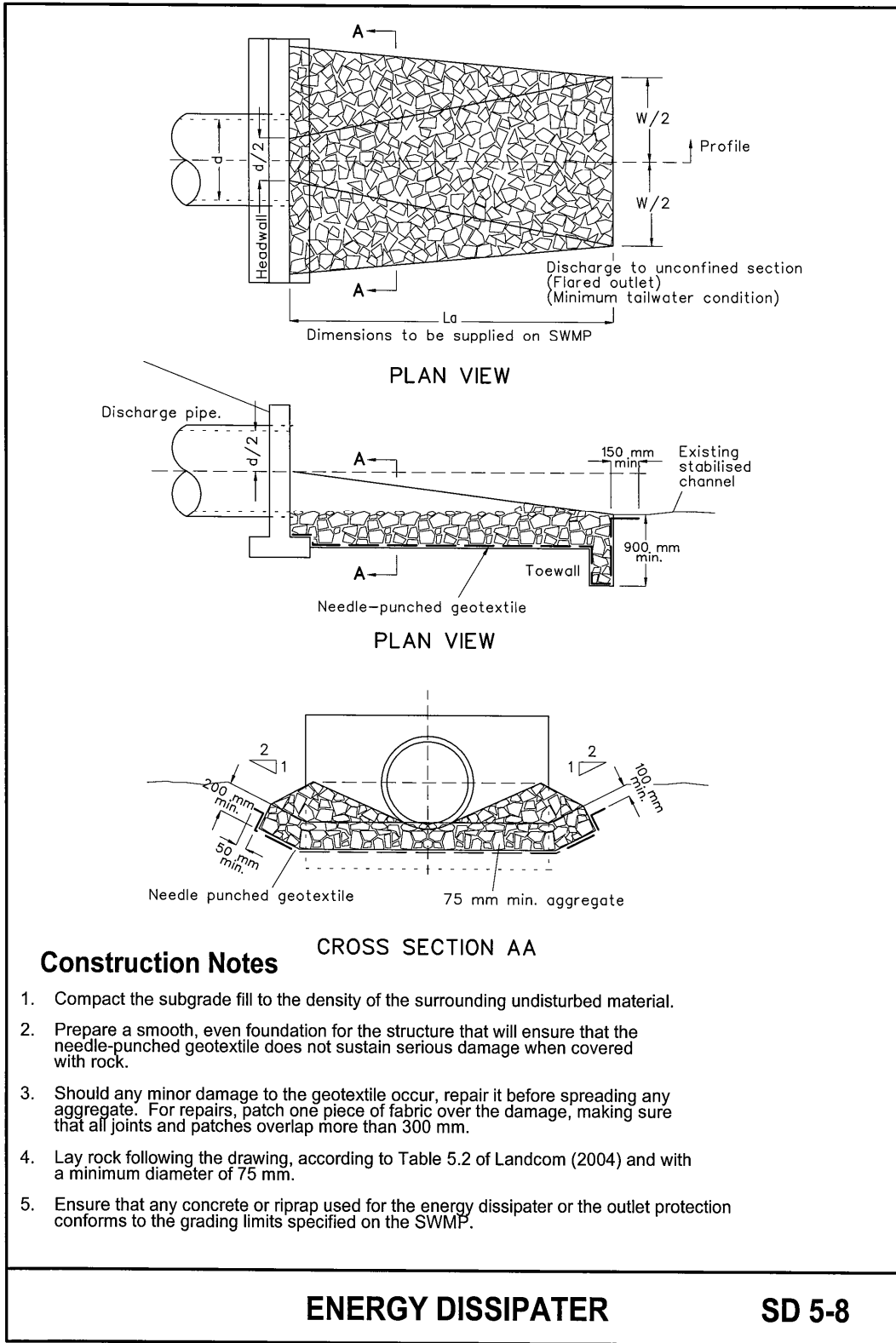

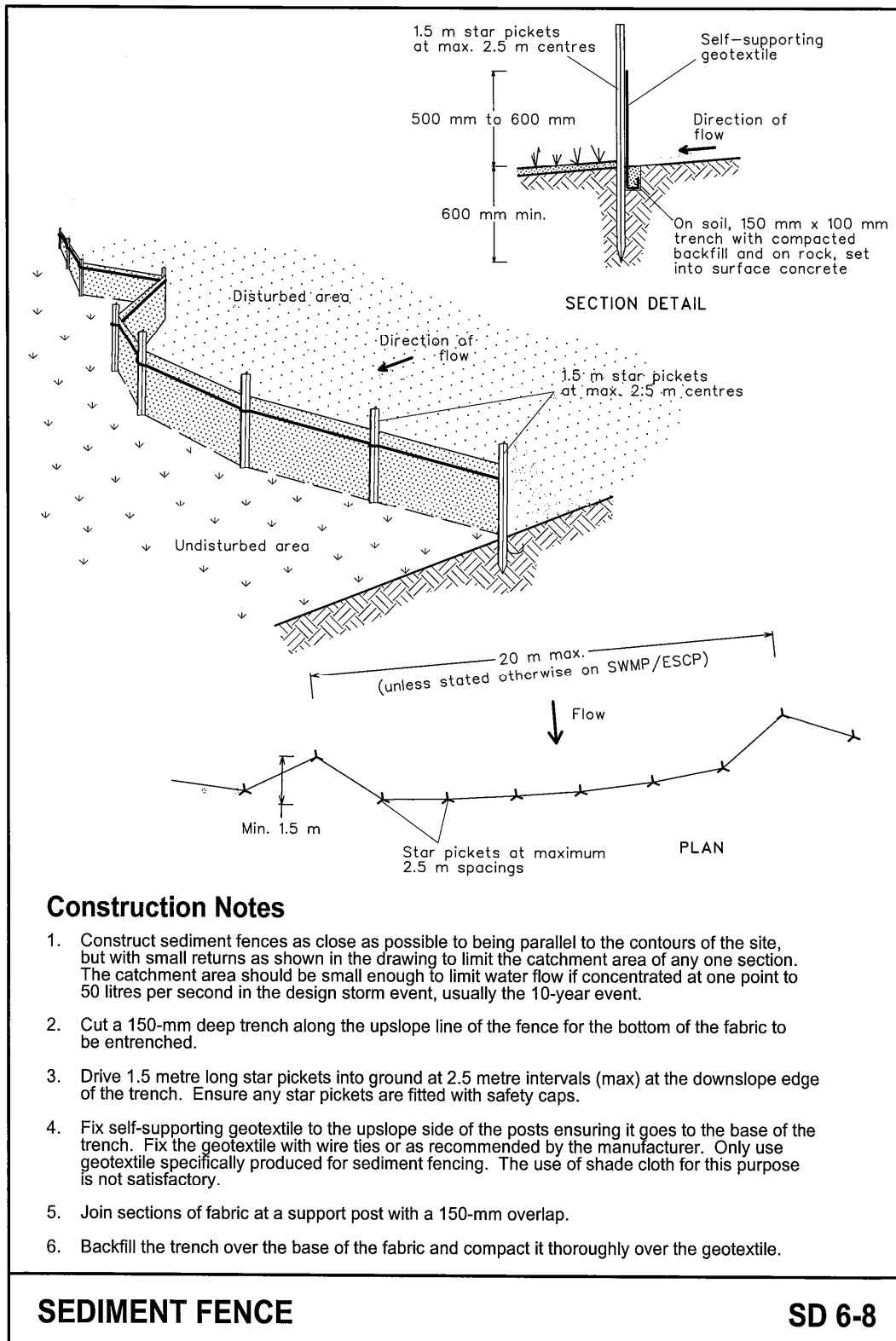

Appendix 3: Pump Requirements

Where pumps are used for temporary cross-drainage, they must be able to convey water at a rate equivalent to the nominated flow event (refer to Table 6.1 in DECC, 2008 for design criteria).

Alternatively, they can be sized according to the length of time they will be in place, for a calculated risk of exceedence of no more than 0.1 (i.e. 10% risk of exceedence during the expected effective life). Risk of exceedence is calculated as follows:

$$P = 1 - 2.718^{(-L/ARI)}$$

Where: P is Probability (risk) of exceedence
L is the length of time the pump will be relied on (years)
ARI is the design storm flow event selected (years)

Example 1:

A coffer dam and pump system will be in place for 3 months while works proceed. It is sized to pump the 2-year flow rate.

Using the above equation: $P = 1 - 2.718^{(-0.25/2)}$
 $P = 0.12$ (i.e. 12%).

This would NOT be adequate because it exceeds the 0.1 (10%) limit.

Example 2:

Water will pond against a fill batter, then be pumped to the low side of the alignment while pipe works occur in the relevant drainage line. The works are expected to take two weeks (i.e. 0.0385 years) and the pump can deliver the equivalent 1-year flow rate.

Using the above equation: $P = 1 - 2.718^{(-0.0385/1)}$
 $P = 0.04$ (i.e. 4%).

This would be adequate because it is below the 0.1 (10%) limit.

Example 3:

A small drainage line will be blocked off while culverts are cleaned and repaired, and any natural flows pumped to the lower end of the culvert. The works are expected to take one week (i.e. 0.0192 years) and the pump can deliver the equivalent 3-month flow rate (i.e. approximately half the 1-year ARI flow).

Using the above equation: $P = 1 - 2.718^{(-0.0192/0.25)}$
 $P = 0.074$ (i.e. 7.4%).

This would be adequate because it is below the 0.1 (10%) limit.

Appendix 4: Drawings & Diagrams

The following 11 drawings provide conceptual, typical details and options for temporary management of both offsite and onsite water during main road construction projects.

Refer to the introductions in each of chapters 5 to 9 to determine which drawings are relevant to each of the scenarios listed.

NEW ONLINE CULVERT (PREFERABLY AS "EARLY WORKS")

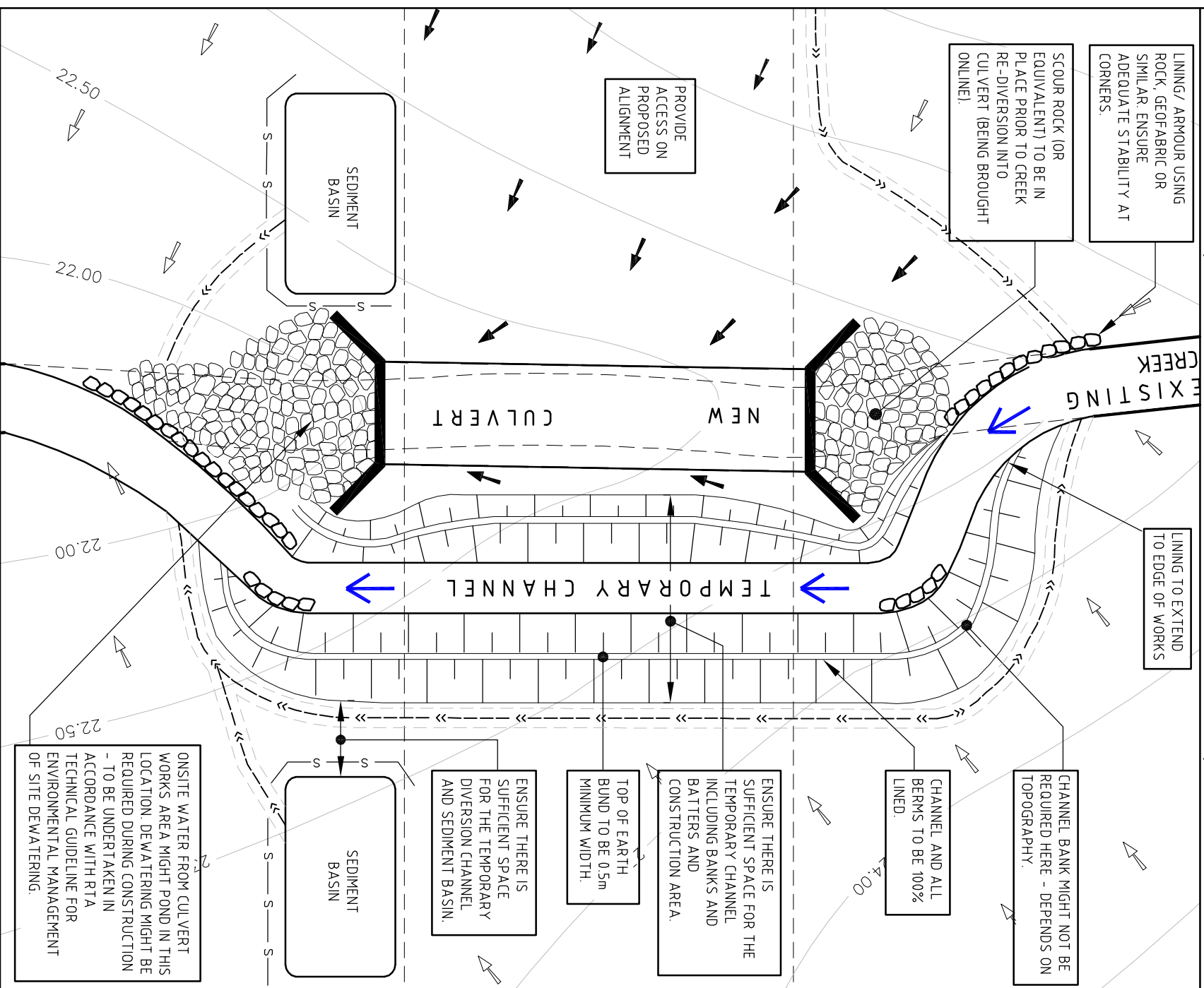

SWMP – ONLINE CULVERT CONSTRUCTION AND CREEK STABILISATION WORKS

NEW ONLINE CULVERT – CONSTRUCTION NOTES

THESE STEPS TO BE UNDERTAKEN IN THE ORDER GIVEN BELOW.

- Stage 1: Temporary Channel Construction
 - Establish diversion drains for offsite water.
 - Construct and line the temporary channel including rock armouring at the existing creek and temporary channel junctions.
 - Construct and line temporary earth bunds.
 - Divert creek flows into this channel. Work downstream to upstream.
- Stage 2: Culvert Construction Works
 - Construct the new culvert including the stabilised culvert inlet and outlets.
 - Stabilise the culvert construction works area once culvert construction works are complete.
- Stage 3: Final diversion and Rehabilitation Works
 - Divert creek flows into new culvert.
 - Temporary channel and bunds to be decommissioned without allowing sediment downstream to creek and the disturbed area stabilised.
 - Diversion drains for offsite water can be redirected to inlet of new culvert on upstream site or can be removed and rehabilitated.

OTHER NOTES

- This design assumes that culvert construction is part of the 'early works' for the site.
- Temporary channel to be sized and lined as per the requirements in Table 6.1 (DECC, 2008) and Table 5.2 (Landcom, 2004).
- Ideally schedule works to periods when rainfall erosivity is low (Refer to Table 4.3 – Landcom, 2004)
- Only undertake in-stream works (e.g. placement of rock) during periods of zero or very low flow and only when the 24 hour weather forecast suggests a significant rain event is not likely.
- Ensure suitable temporary groundcover materials (e.g. geofabric or black plastic) are located on site for rapid stabilisation of exposed soils within in-stream locations if an unexpected rain or flow event occurs.
- No culvert works are to occur until creek flows are successfully diverted into the stabilised temporary channel.
- Culverts are to be completed before being allowed to convey flows. This includes all inlet and outlet protection, wingwalls etc.
- Stabilisation, as defined by the Blue Book, means achieving:
 - For concentrated flows- At least 70% vegetation cover (or equivalent) within 10 days AND using only materials that are suitable in concentrated flow conditions (refer to Tables A3 and D1 in the Blue Book for suitability).
 - For all other areas- At least 60% vegetation cover (or equivalent) in 20 days AND 70% in 2 months.
- A management regime should be in place to address the risk of these works creating a flooding issue due to construction of the channel during construction.
- If temporary access is required across the existing creek or a diversion channel, use a temporary water crossing – see standard drawing 5-1 in Blue Book Vol 1 (Landcom, 2004).
- Minimise the time that soil is exposed to erosion.

STANDARD DRAWINGS FROM VOL 1 OF THE BLUE BOOK (LANDCOM, 2004) USED HERE:

- Sediment fence: SD 6-8
- High flow earth bank (diversion drain): SD 5-6
- Energy dissipater: SD 5-8
- Temporary waterway crossing: SD 5-1

AT ALL TIMES DURING WORKS, ENSURE THAT 'OFFSITE' WATER IS PASSED AROUND OR THROUGH THE SITE WITHOUT COMING INTO CONTACT WITH EXPOSED SOIL OR 'ONSITE' WATER

THIS SCENARIO ALSO APPLIES TO:

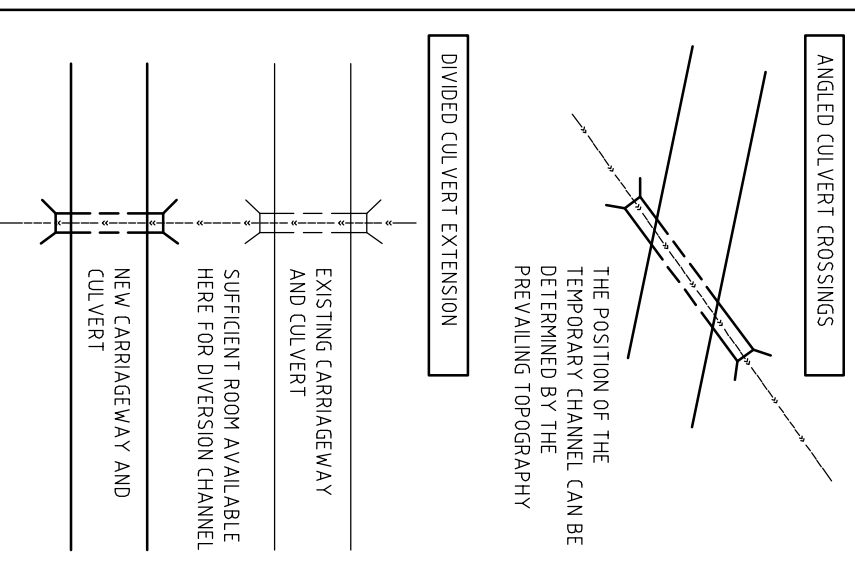

THE APPLICATION OF THIS SCENARIO TO DIVIDED CULVERT EXTENSIONS IS DEPENDENT ON WHETHER THERE IS ENOUGH AVAILABLE SPACE. IF SPACE IS LIMITED PART OF THE TEMPORARY CHANNEL CAN BE CONSTRUCTED OUT OF SHEET PILING OR SIMILAR OR ALTERNATIVELY THE SITE SHOULD BE STABILISED AS FOR A CONTINUOUS ONLINE CULVERT EXTENSION

LEGEND

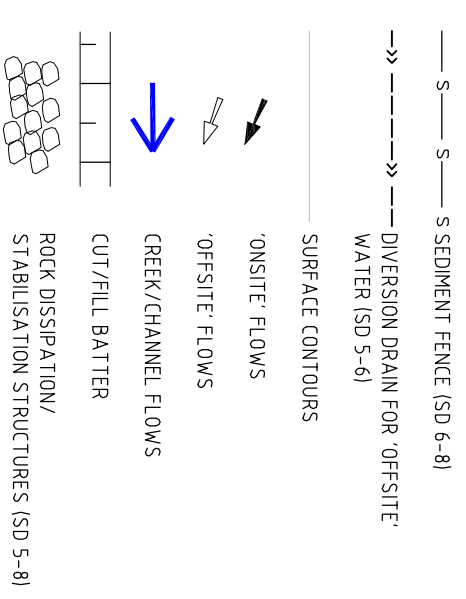

NOTE THAT NOT ALL ONSITE WATER MANAGEMENT AND SEDIMENT CONTROLS ARE SHOWN HERE.

**NEW OFFLINE CULVERT
(PREFERABLY AS "EARLY WORKS")**

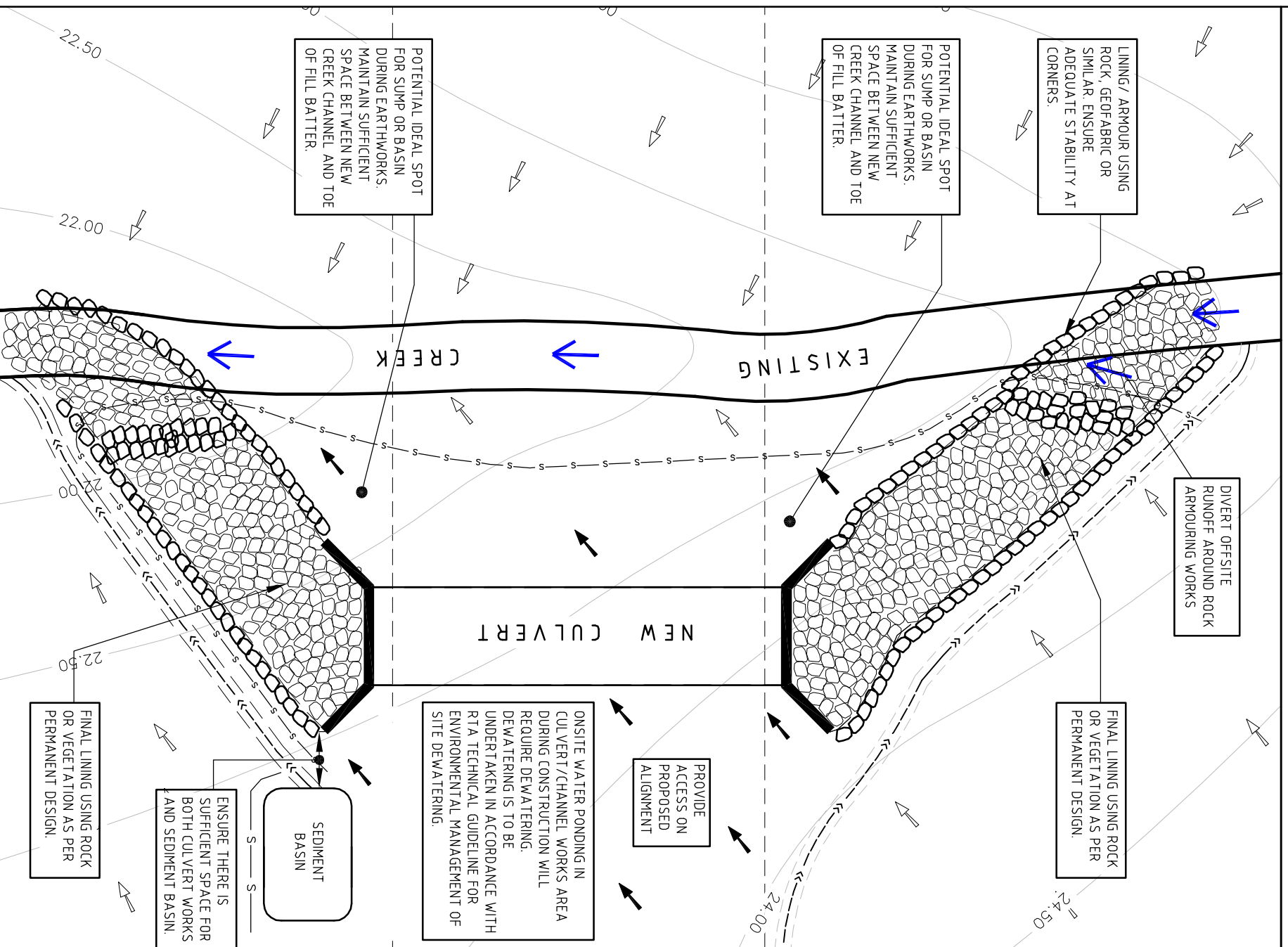

**SWMP – OFFLINE CULVERT CONSTRUCTION
AND CREEK STABILISATION WORKS**

NEW OFFLINE CULVERT – CONSTRUCTION NOTES

THESE STEPS TO BE UNDERTAKEN IN THE ORDER GIVEN BELOW.

- Stage 1: Site Preparation Works**
- Establish diversion drains for offsite water.
 - Install berms to block off new channel and ensure all works remain offline from the existing creek.

- Stage 2: Culvert Construction Works**
- Construct the new culvert including the stabilised culvert inlet and outlets.
 - Stabilise the culvert construction works area.

- Stage 3: Final Diversion and Rehabilitation Works**
- Install in-stream (offline) rock armouring at the locations where flows are turned into and out of the new channel.
 - Remove berms used to block off new channel during construction works starting at downstream end.
 - Divert creek flows into new culvert.
 - Disturbed area to be stabilised.

STANDARD DRAWINGS FROM VOL 1 OF THE BLUE BOOK (LANDCOM, 2004) USED HERE:

- Sediment fence: SD 6-8
- High flow earth bank (diversion drain): SD 5-6
- Energy dissipater: SD 5-8
- Temporary waterway crossing: SD 5-1

OTHER NOTES

1. This design assumes that culvert construction is part of the 'early works' for the site.
3. Ideally schedule works to periods when rainfall erosivity is low (Refer to Table 4.3 – Landcom, 2004)
4. Only undertake in-stream works (e.g. placement of rock) during periods of zero or very low flow and only when the 24 hour weather forecast suggests a significant rain event is not likely.
5. Ensure suitable temporary groundcover materials (e.g. geofabric or black plastic) are located on site for rapid stabilisation of exposed soils within in-stream locations if an unexpected rain or flow event occurs.
6. Culverts are to be completed before being allowed to convey flows. This includes all inlet and outlet protection, wingwalls etc.
7. Stabilisation, as defined by the Blue Book, means achieving:
 - For concentrated flows – At least 70% vegetation cover (or equivalent) within 10 days AND using only materials that are suitable in concentrated flow conditions (refer to Tables A3 and D1 in the Blue Book for suitability).
 - For all other areas – At least 60% vegetation cover (or equivalent) in 20 days AND 70% in 2 months.
8. If temporary access is required across the existing creek or a diversion channel, use a temporary water crossing (see standard drawing list).
9. Minimise the time that soil is exposed to erosion.

AT ALL TIMES DURING WORKS, ENSURE THAT 'OFFSITE' WATER IS PASSED AROUND OR THROUGH THE SITE WITHOUT COMING INTO CONTACT WITH EXPOSED SOIL OR 'ONSITE' WATER

THIS SCENARIO ALSO APPLIES TO ANGLED CULVERT CROSSINGS

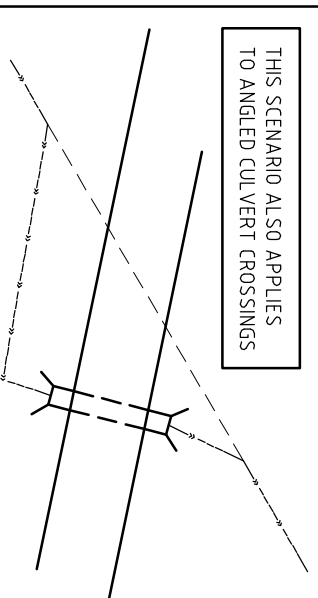

LEGEND

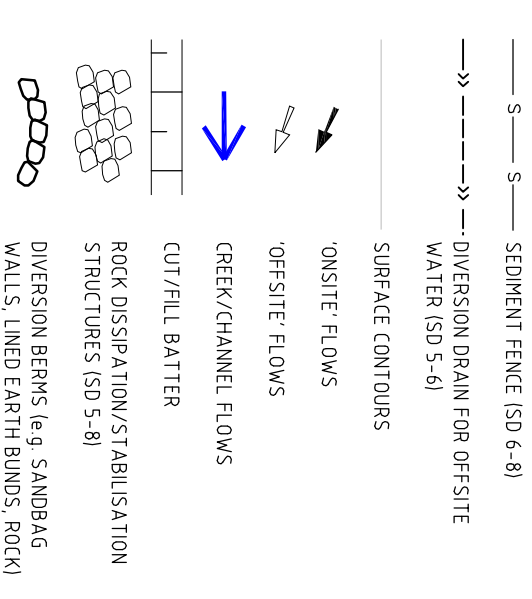

NOTE THAT NOT ALL ONSITE WATER MANAGEMENT AND SEDIMENT CONTROLS ARE SHOWN HERE.

CONTINUOUS CULVERT EXTENSION (ONLINE)

OPTION 1

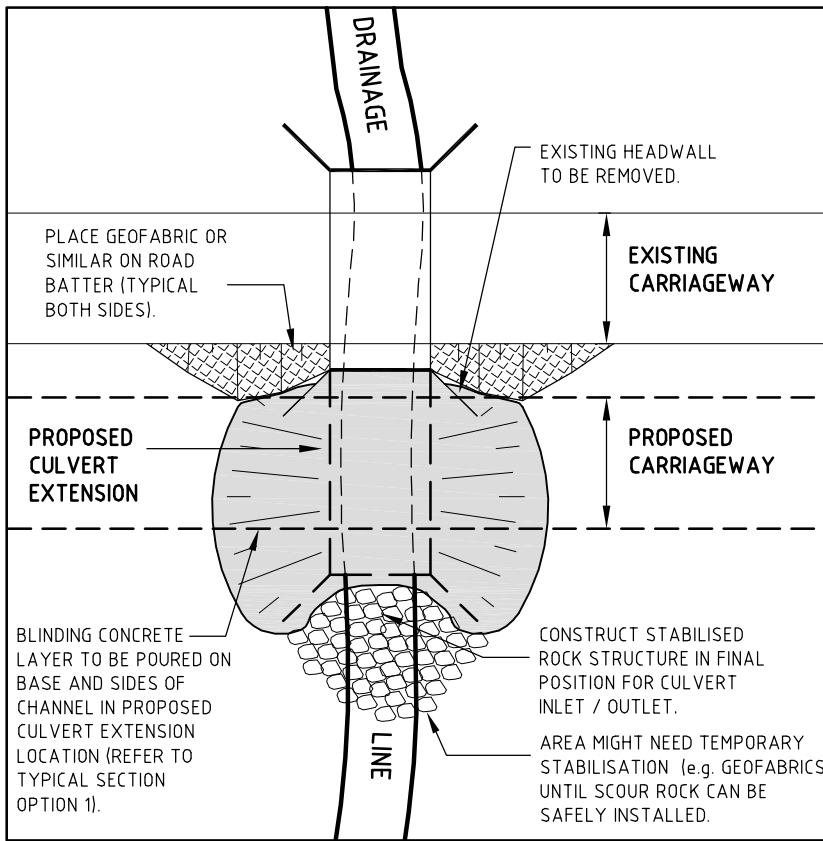

SITE STABILISATION PROCEDURE

OTHER NOTES

- For divided culvert extensions this stabilisation method could also be applied or alternatively the flows could be diverted as for a new online culvert.
- Note that this method is not suitable for perennial creeks unless additional measures (e.g. pumping or coffer dams) can be reliably included as well.
- This method might not be appropriate where there is a significant depth of unsuitable soil material to be removed.
- For systems with very minor flows in dry periods, temporary damming of flows might be required to hold water back for the nominated work period until the blinding concrete layer and rock is placed.
- Note that not all onsite water management and sediment controls are shown here.

CONSTRUCTION NOTES

WORKS TO BE UNDERTAKEN IN THE ORDER GIVEN BELOW

Prior to undertaking any construction or earthworks ensure suitable temporary groundcover materials (e.g. geofabric or black plastic) are located on site for rapid stabilisation of exposed soils if an unexpected rain or flow event occurs.

1. Watch the weather forecast for a dry period (a period longer than the time required to complete earthworks up to the required level).
2. When a dry period is forecast, undertake earthworks quickly (preferably in less than three days).
3. Pour blinding concrete layer and lay rock inlet / outlet.
4. Lay geofabric (or similar) on existing road batter.

(Ensure steps 2, 3 and 4 occur within the forecast period of dry weather and no flow)

5. Complete culvert construction works over the top of the blinding concrete layer.
6. Maintain the blinding layer until the culvert extension is complete and stabilised. once flows are secure within the new culverts, excess blinding can be removed if desired.

At any time during steps 1 - 4 where a significant rain or flow event is forecast or if the site is left unattended for prolonged periods temporary groundcover should be applied to all exposed soils in the works area.

ENSURE THAT 'OFFSITE' CREEK FLOWS DO NOT COME INTO CONTACT WITH EXPOSED SOIL OR 'ONSITE' WATER

NOTE: MAINTAIN OR INSTALL TEMPORARY GROUND COVER THROUGH FLOW AREA ANYTIME FLOWS ARE IMMINENT.

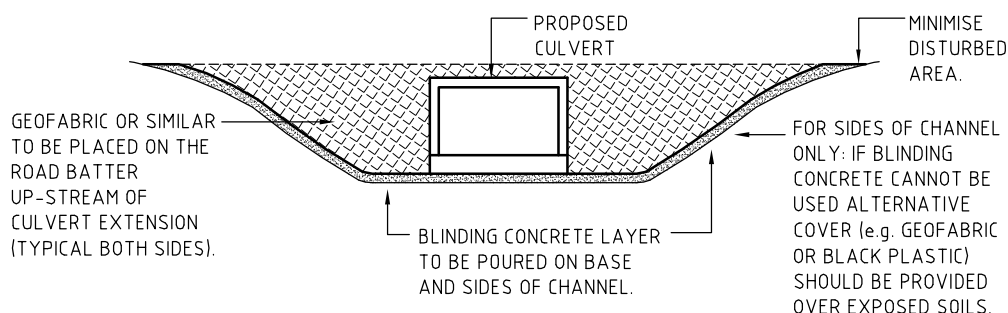

TYPICAL SECTION – OPTION 1

CONTINUOUS CULVERT EXTENSION (ONLINE)

OPTION 2

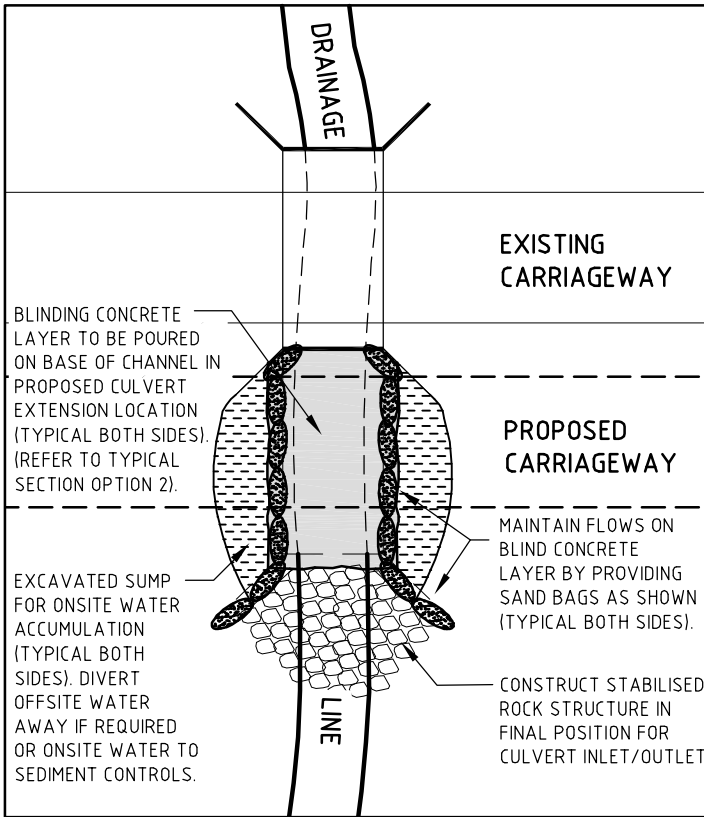

SITE STABILISATION PROCEDURE

CONSTRUCTION NOTES

WORKS TO BE UNDERTAKEN IN THE ORDER GIVEN BELOW

Prior to undertaking any construction or earthworks ensure suitable temporary groundcover materials (e.g. geofabric or black plastic) are located on site for rapid stabilisation of exposed soils if an unexpected rain or flow event occurs.

1. Watch the weather forecast for a dry period (a period longer than the time required to complete earthworks up to the required level).
2. When a dry period is forecast, undertake earthworks quickly (preferably in less than three days).
3. Pour blinding concrete layer and lay rock inlet / outlet.
4. Position sand bags on the blind concrete layer.

(Ensure steps 2, 3 and 4 occur within the forecast period of dry weather and no flow)

5. Complete culvert construction works over the top of the blinding concrete layer. Take care not to disturb the integrity of the blinding layer.
6. Maintain the sandbag walls on the base slab if a flow event occurs.

At any time during steps 1 - 4 where a significant rain or flow event is forecast or if the site is left unattended for prolonged periods temporary groundcover should be applied to all exposed soils in the works area.

OTHER NOTES

- For divided culvert extensions this stabilisation method could also be applied or alternatively the flows could be diverted as for a new online culvert.
- Note that this method is not suitable for perennial creeks unless additional measures (e.g. pumping or coffer dams) can be reliably included as well.
- This method might not be appropriate where there is a significant depth of unsuitable soil material to be removed.
- For systems with very minor flows in dry periods, temporary damming of flows might be required to hold water back for the nominated work period until the blinding concrete layer and rock is placed.
- Note that not all onsite water management measures and sediment controls are shown here.

ENSURE THAT 'OFFSITE' CREEK FLOWS DO NOT COME INTO CONTACT WITH EXPOSED SOIL OR 'ONSITE' WATER

NOTE: MAINTAIN OR INSTALL TEMPORARY GROUND COVER THROUGH FLOW AREA ANYTIME FLOWS ARE IMMINENT.

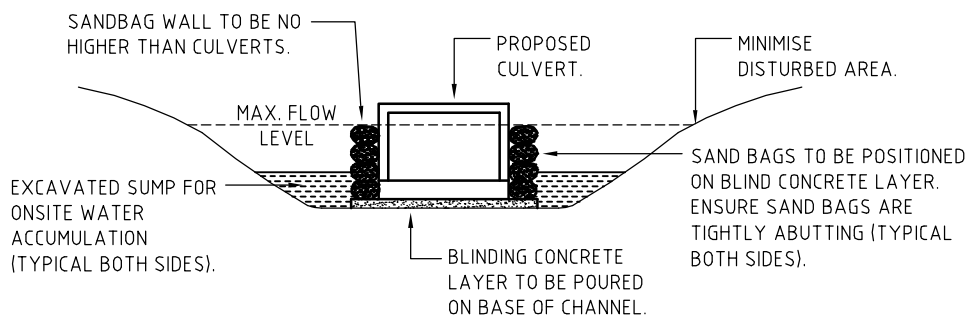

TYPICAL SECTION – OPTION 2

CONTINUOUS CULVERT EXTENSION (ONLINE)

OPTION 3

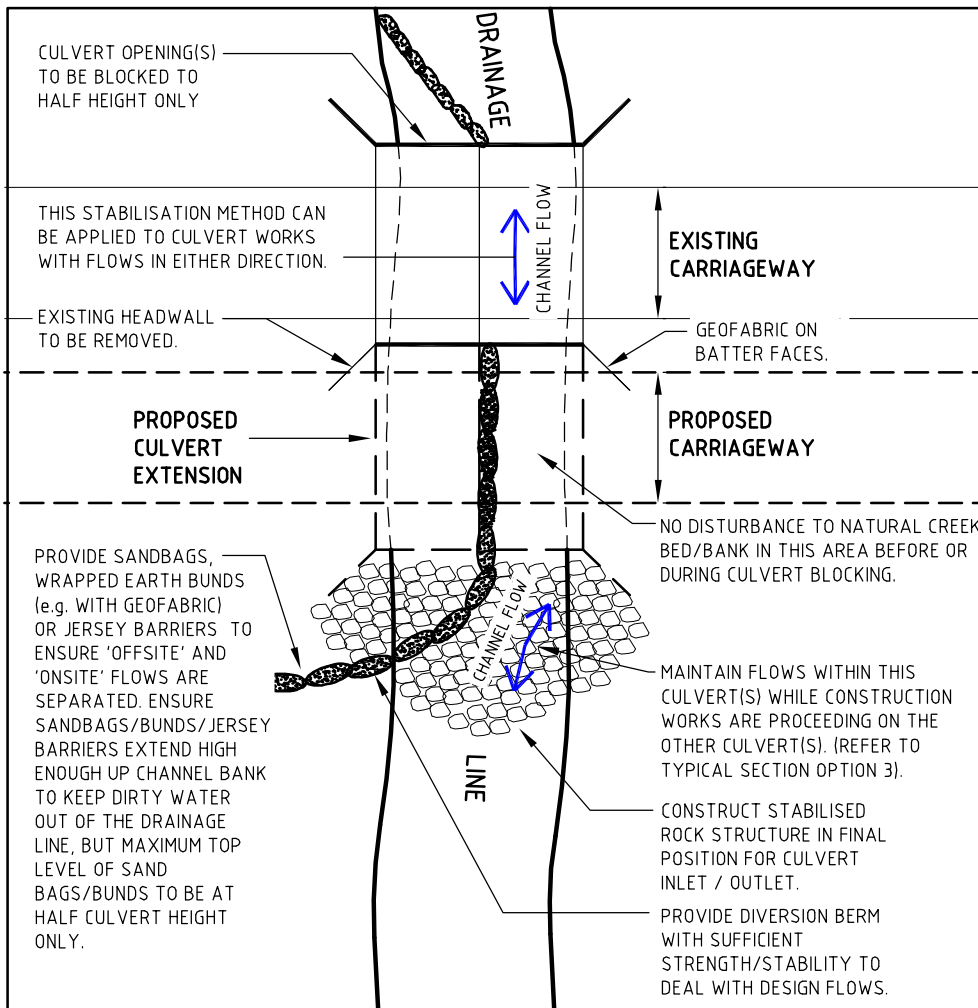

OTHER NOTES

- This option will only work when existing ground surface level can be maintained in at least one culvert cell. Therefore this method might not work for deep excavations requiring benching.
- Suitable for use in perennial streams providing in-stream works are conducted when flows are minimal.
- However, regardless of scheduling and timing the adopted controls need to be considerate of the risk of significant flows at any time.
- Note that not all water management and sediment controls are shown here.

AT ALL TIMES DURING WORKS, ENSURE THAT 'OFFSITE' WATER IS PASSED AROUND OR THROUGH THE SITE WITHOUT COMING INTO CONTACT WITH EXPOSED SOIL OR 'ONSITE' WATER

SITE STABILISATION PROCEDURE

CONSTRUCTION NOTES

WORKS TO BE UNDERTAKEN IN THE ORDER GIVEN BELOW

Prior to undertaking any construction or earthworks ensure suitable temporary groundcover materials (e.g. geofabric or black plastic) are located on site for rapid stabilisation of exposed soils if an unexpected rain or flow event occurs.

Stage 1.

1. Monitor creek flows ensuring flows levels are not too high.
2. Position sandbags/bunds around culvert works area and block existing culvert end to half culvert height only.
3. Undertake culvert extension construction works only on the blocked side of the culvert(s).
4. Complete inlet/outlet protections.

Stage 2

5. Divert the creek flows into the newly constructed culvert extension by blocking off the alternate side using a half-height wall/bund.
6. Complete the culvert extension on the other side including the stabilised inlet/outlet.

At any time where a significant rain or flow event is forecast or if the site is left unattended for prolonged periods temporary groundcover should be applied to all exposed soils in the works area.

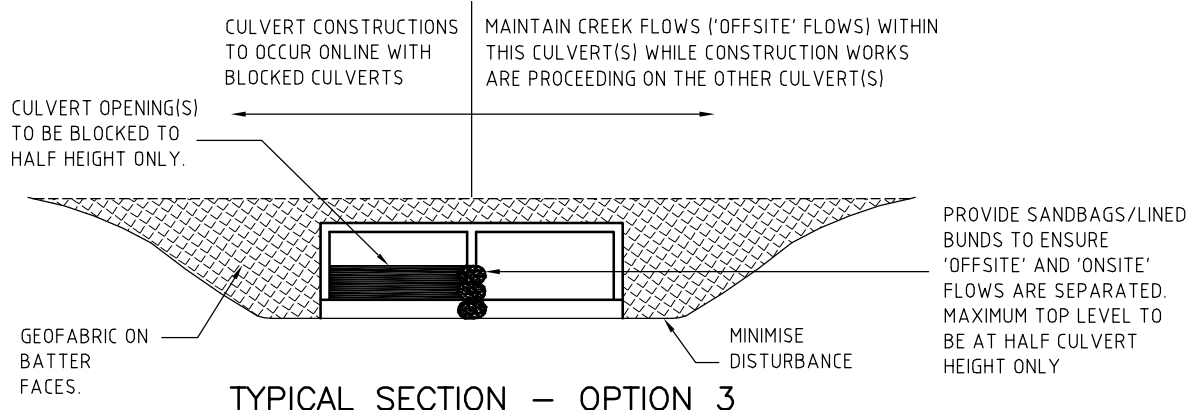

TYPICAL SECTION – OPTION 3

TEMPORARY 'OFFSITE' WATER CONTROLS FOR CONSTRUCTION WORKS IN ROAD CUTTINGS

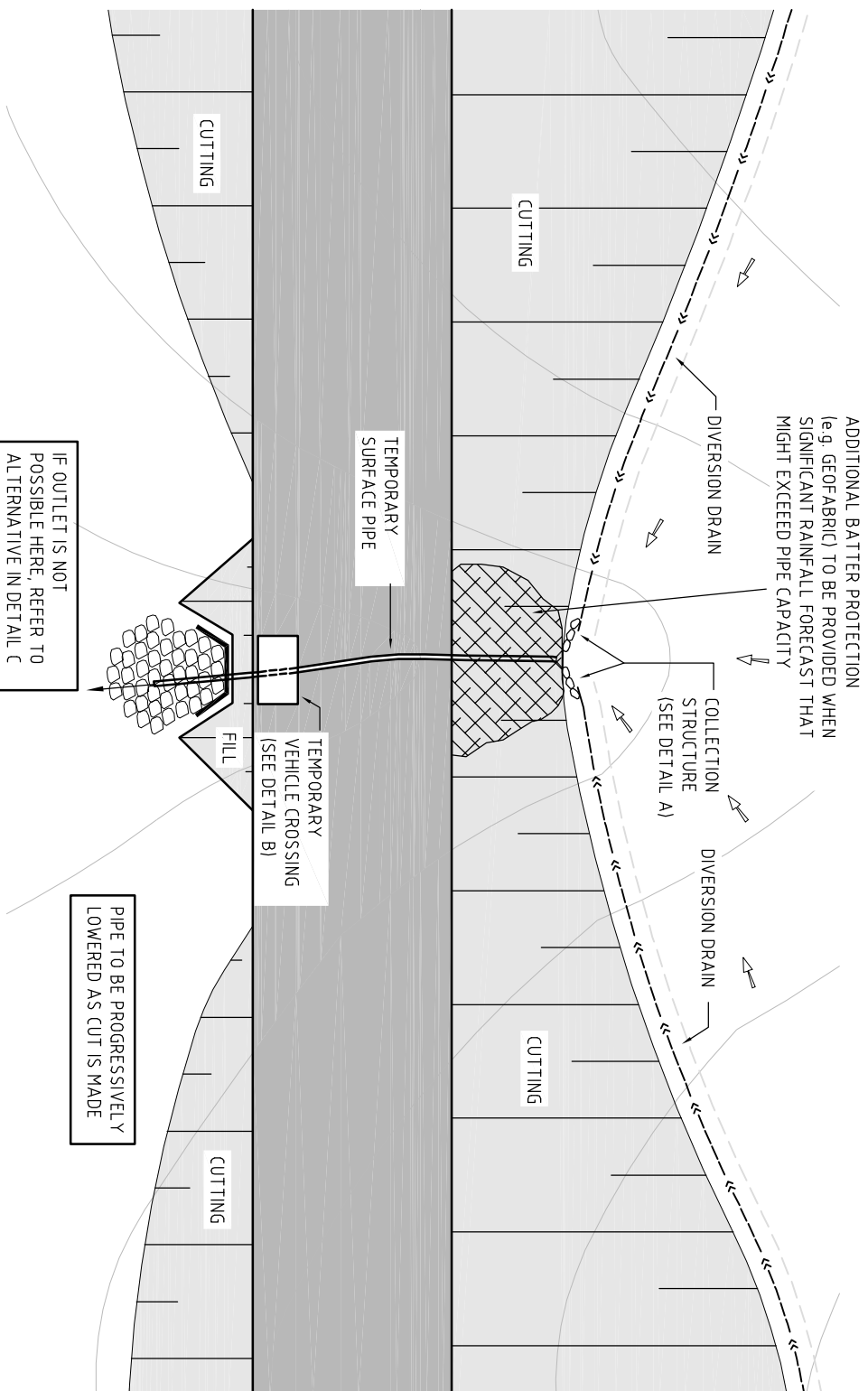

PIPE TO BE PROGRESSIVELY LOWERED AS CUT IS MADE

- CONSTRUCTION NOTES**
1. Permanent diversion drains are to be used as 'offsite' diversion drains during construction works.
 2. Ensure there is continuous fall on the temporary flexible pipe (or temporary sacrificial pipe).
 3. The temporary pipe is to be progressively lowered as the cut is made.
 4. It is not essential that the temporary pipe follows the invert of the depression, however, fall on the pipe must be maintained.
 5. The inlet and outlets of the temporary pipe are to stabilised. They are to be located beyond the limit of works to ensure no onsite runoff is captured.
 6. The collection structure used to direct 'offsite' flows into the temporary pipe is to be construction out of either rock or lined earth berms.
- OTHER NOTES**
7. This drawing only illustrates 'offsite' water controls. 'Onsite' water management controls will also be required.

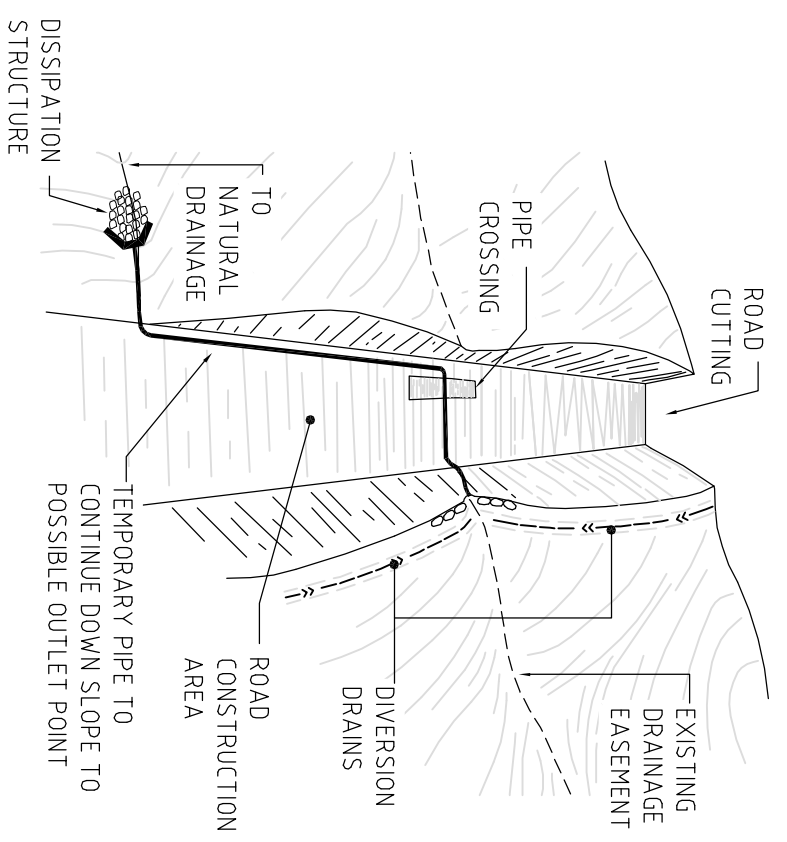

AT ALL TIMES DURING WORKS, ENSURE THAT 'OFFSITE' WATER IS PASSED AROUND OR THROUGH THE SITE WITHOUT COMING INTO CONTACT WITH EXPOSED SOIL OR 'ONSITE' WATER

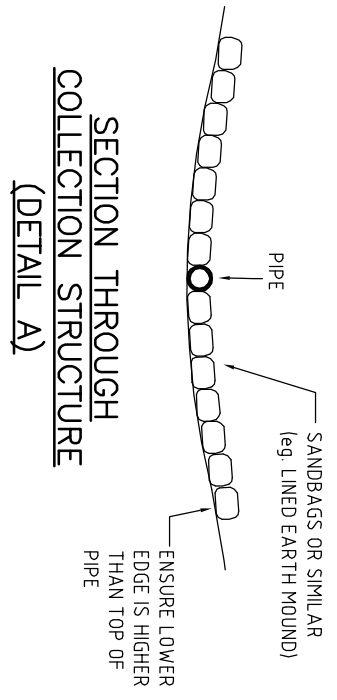

LEGEND

--->	DIVERSION DRAIN FOR 'OFFSITE' WATER (SD 5-6)
---	SURFACE CONTOURS
---	'OFFSITE' FLOWS
⊞	ROCK STABILISED OUTLET (SD 5-8)
⊞	CUT / FILL BATTER

NOTE THAT NOT ALL ONSITE WATER MANAGEMENT AND SEDIMENT CONTROLS ARE SHOWN HERE.

TYPICAL PIPE CROSSING DETAILS (DETAIL B)

OPTIONS INCLUDE:

1. TRENCH PIPE AT CROSSING POINT
2. PRE-FABRICATED RAMP

MAINTAIN PIPE FALL
3. TEMPORARY RUBBLE CROSSING

TEMPORARY WATER MANAGEMENT ON A ROADSIDE CUTTING

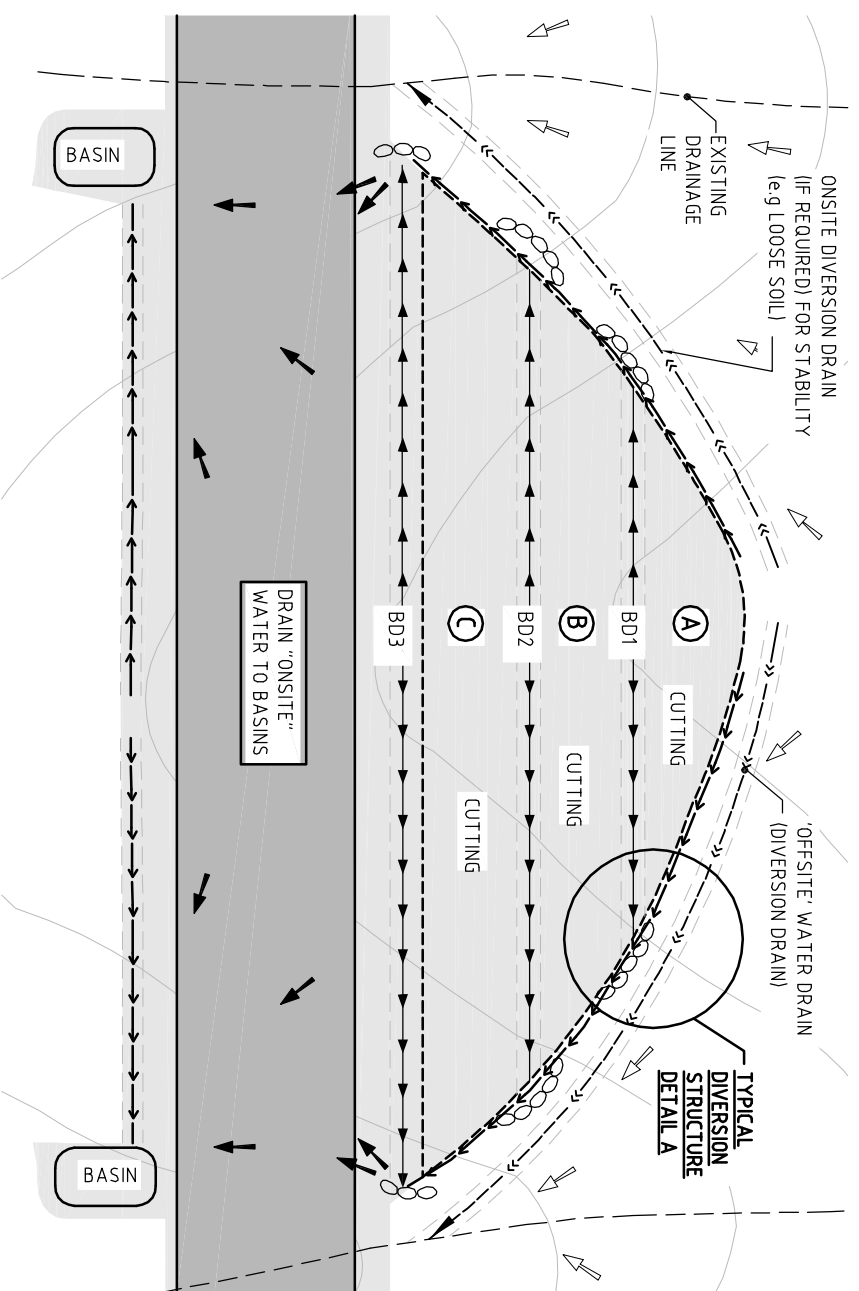

- GENERAL NOTES**
1. Progressive stabilisation of batters is essential. Each section of the batter should be shaped, topped and rehabilitated before proceeding to the next section.
 2. Permanent cut off drains used as 'offsite' drains during construction works.
 3. Take care with mixing flows from 'offsite' (cut off) drains with flows from berm drains ('onsite' water until upslope batter is vegetated). Diversion structures should be used to ensure this (Refer to 'Typical Diversion Structure Detail A').

4. All 'onsite' water is to drain to a sediment trap/basin.
5. Outlet 'offsite' water drains to existing drainage line or culvert.
6. A suitable 'offsite' water management system is to be used for conveying 'offsite' flows from the drainage line through the worksite.
7. Note that not all onsite water management and sediment controls are shown here.

CONSTRUCTION NOTES

WORKS TO BE UNDERTAKEN IN THE ORDER GIVEN BELOW

1. Permanent diversion drains ('offsite' water drains) to be established.
2. Earthworks on upper section of cutting (i.e. section A) to be undertaken including construction of BD1.
3. Construction of BD1 must include diversion structures as per Phase 1 detail.
4. Section A should be stabilised as per Phase 2 detail.
5. Once section A is successfully stabilised (i.e. at least 60% ground cover has been achieved), BD1 can be connected to the cut off drain as per Phase 3 detail.
6. Earthworks can now proceed on the next section down (i.e. section B) and the process above (2 to 4), should be again carried out.
7. This process should continue for the entire cutting (i.e. section C and any lower sections if present).

PROGRESSIVE STABILISATION OF BATTERS IS ESSENTIAL. EACH SECTION OF THE BATTER SHOULD BE SHAPED, TOPSOILED, AND REHABILITATED BEFORE PROCEEDING TO THE NEXT SECTION.

AT ALL TIMES DURING WORKS, ENSURE THAT 'OFFSITE' WATER IS PASSED AROUND OR THROUGH THE SITE WITHOUT COMING INTO CONTACT WITH EXPOSED SOIL OR 'ONSITE' WATER

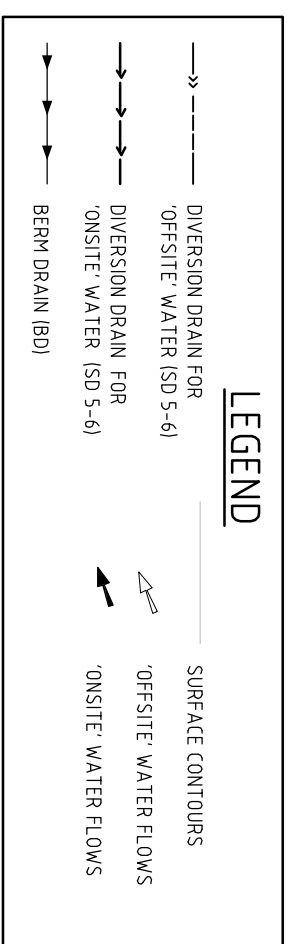

WHEN THE BATTER ABOVE (BATTER A) IS STABILISED THE SECOND LEVEL OF EARTHWORKS CAN OCCUR - BATTER B TO BE STABILISED. CUT TO FALL TOWARDS BD2.

WHEN THE BATTER ABOVE (BATTER B) IS STABILISED THE NEXT LEVEL OF EARTHWORKS CAN OCCUR - BATTER C TO BE STABILISED.

NEW ROAD CARRIAGEWAY

EARTHWORKS TO OCCUR ON UPPER SECTION OF CUTTING FIRST - BATTER A TO BE STABILISED. CUT TO FALL TOWARDS BD1.

TYPICAL SECTION THROUGH ROADSIDE CUTTING

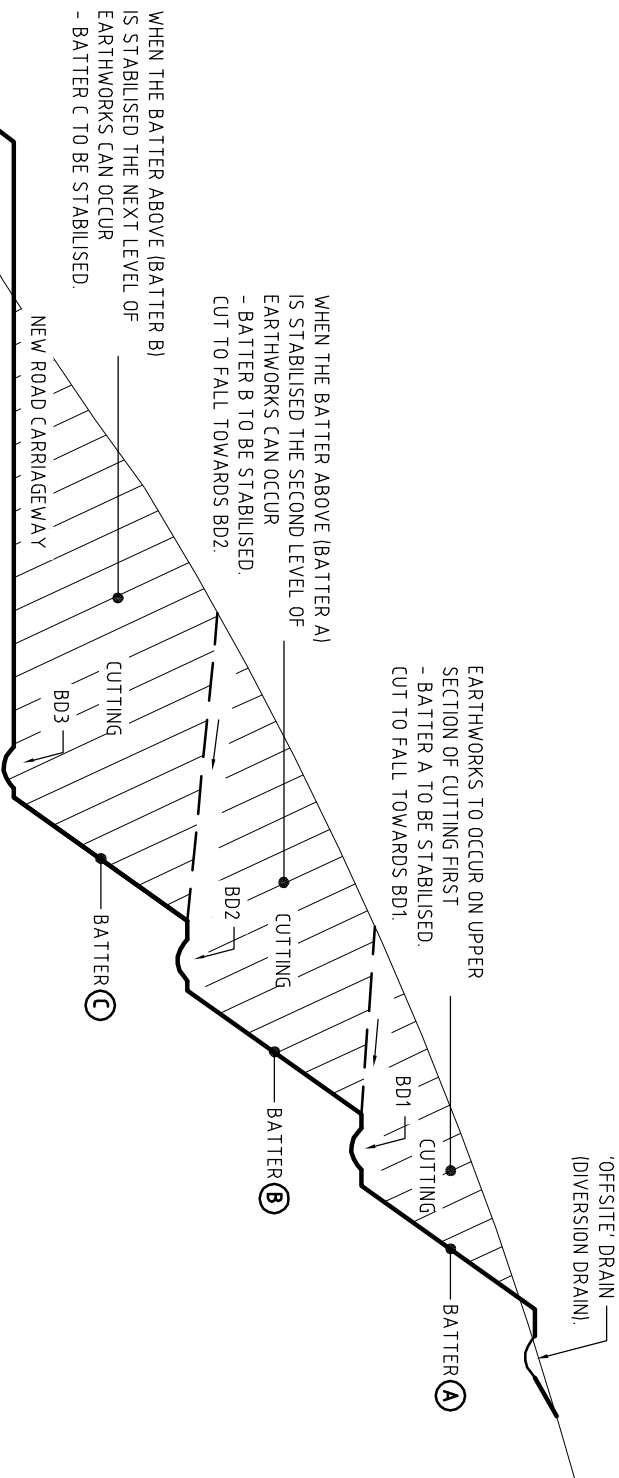

Stabilisation means achieving:

- For concentrated flows - At least 70% vegetation cover (or equivalent) within 10 days AND using only materials that are suitable in concentrated flow conditions (refer to Tables A3 and D1 in the Blue Book for suitability).
- For all other areas - At least 60% vegetation cover (or equivalent) in 20 days AND 70% in 2 months.

TYPICAL DIVERSION STRUCTURE DETAIL A

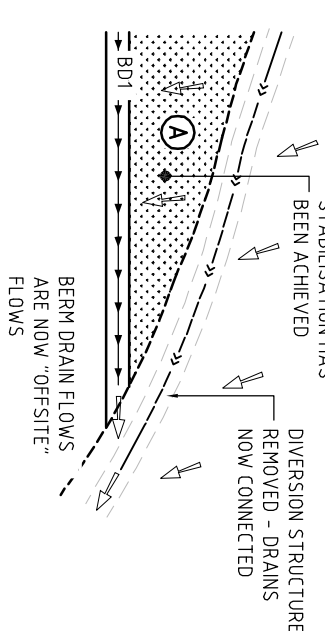
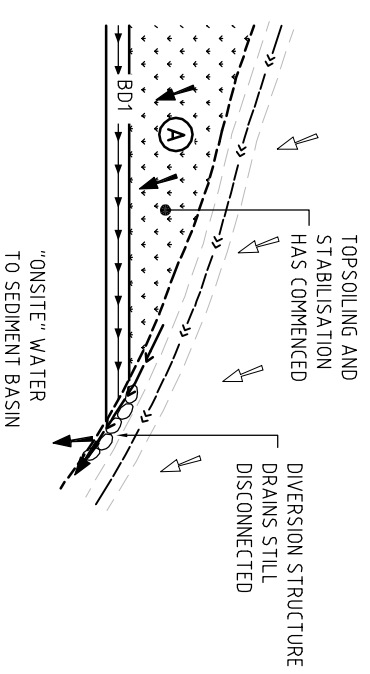
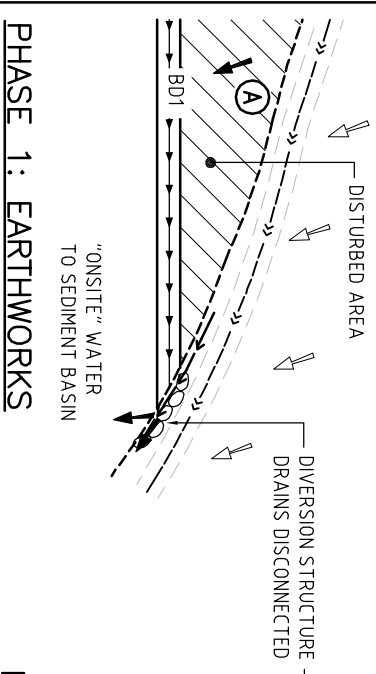

TEMPORARY WATER MANAGEMENT OF ROAD WORKS POSITIONED IN DEPRESSION

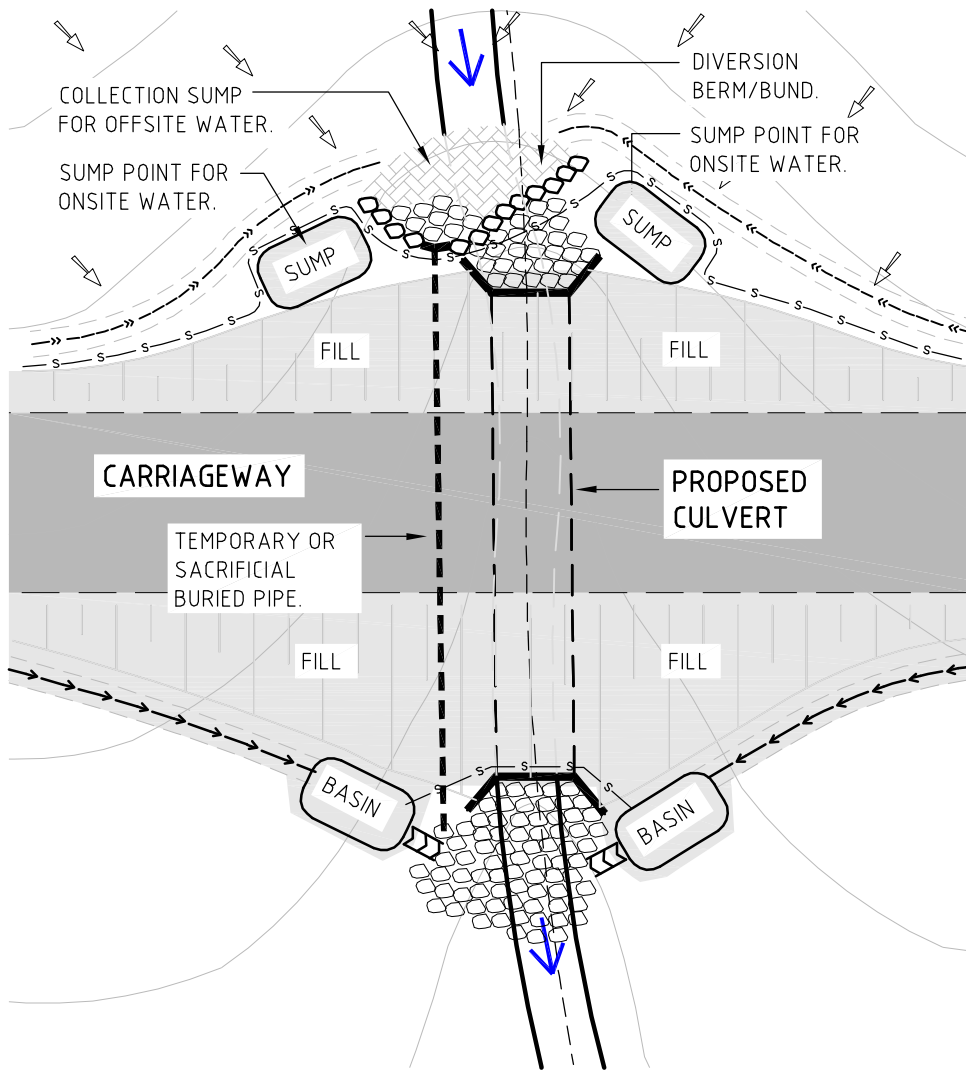

- THIS SCENARIO IS ONLY APPLICABLE FOR DEPRESSIONS AND INTERMITTENT SMALL CREEKS NOT FOR PERENNIAL OR LARGER SYSTEMS.
- AT ALL TIMES DURING WORKS, ENSURE THAT 'OFFSITE' WATER IS PASSED AROUND OR THROUGH THE SITE WITHOUT COMING INTO CONTACT WITH EXPOSED SOIL OR 'ONSITE' WATER.
- ADDITIONAL BATTER PROTECTION (e.g. GEOFABRIC) TO BE PROVIDED WHEN SIGNIFICANT RAINFALL FORECAST THAT MIGHT EXCEED PIPE CAPACITY.

LEGEND

- >> ——— OFFSITE WATER DIVERSION DRAIN (SD 5-6)
- >>> ——— ONSITE WATER DRAINS (SD 5-6)
- SURFACE CONTOURS
- ROCK STABILISED OUTLET (SD)
- CUT/FILL BATTER
- DIVERSION BERM (SD)
- CREEK/PIPE FLOW ROUTE
- AREA TO BE LINED
- SPILLWAY
- s—— SEDIMENT FENCE (SD 6-8)

- ### CONSTRUCTION NOTES
- THESE STEPS TO BE UNDERTAKEN IN THE ORDER GIVEN BELOW.**
- Stage 1: Establish Temporary Diversion
1. Monitor creek flows ensuring flow levels are not too high.
 2. Establish diversion drains for offsite water.
 3. Position the temporary pipe and construct the stabilised inlet and outlets for this pipe.
 4. Establish the diversion berm (including lining where applicable) to direct water into the temporary pipe.
 5. Line the collection sump up to the height of the top pipe level.
 6. Flows to be diverted into the temporary pipe. This is to take place prior to undertaking any bulk earthworks, stripping or culvert constructions.
- Stage 2: Culvert Construction Works
7. Prior to undertaking any stripping, earthworks or culvert construction works, 'onsite' soil and water management controls are to be established.
 8. Complete bulk earthworks and construct the new culvert including the stabilised culvert inlet and outlets.
 9. Once the bulk earthworks and the culvert constructions including stabilisation of culvert inlet / outlets have been completed, creek flows can be diverted into new culvert and temporary pipe removed or capped / sealed.

- ### GENERAL NOTES
- An offset pipe is to be used where depressions are to be filled before culvert works (eg. to provide access during bulk earthworks).
 - Ensure offsite flows are diverted into the temporary pipe prior to undertaking any stripping, bulk earthworks or culvert construction works.
 - Include seepage collars on the temporary pipe.
 - Temporary pipes are to include seepage collars.
 - Water will pool in the collection sump up to the level of the temporary pipe invert. The area of the collection sump up to the height of the top of pipe level should be lined with rock, geofabric, plastic or similar (NOT BARE SOIL).
 - The inlet and outlets of the temporary pipe are to be stabilised with rock.
 - The diversion berms used to direct 'offsite' flows into the temporary pipe are to be constructed out of either rock or lined earth berms.
 - Where sediment basins are not possible to construct in steep locations with space restrictions an alternative sediment device must be implemented (i.e. a sediment trap made out of sediment fence, sandbags or lined earth bunding). This is only suitable in very small catchments.
 - Creek flows can only be re-diverted into the new culvert once culvert constructions have been completed and the culvert inlet and outlets have been rock lined and stabilised.
 - If required, temporary pipes can be left in place after culvert works are completed.
 - If temporary pipes are to remain in place, drain them, then cap or seal them to minimise the risk of water ingress.
 - Note that not all onsite water management and sediment controls are shown here.

CUT / FILL BATTER WATER MANAGEMENT

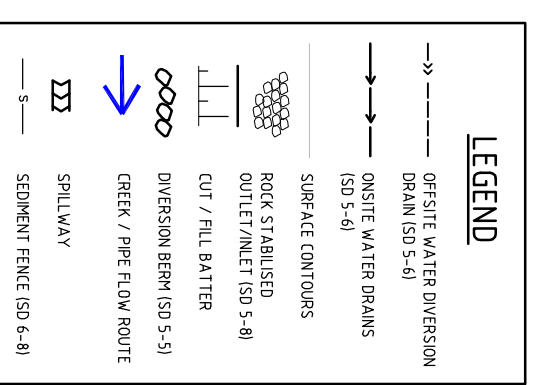
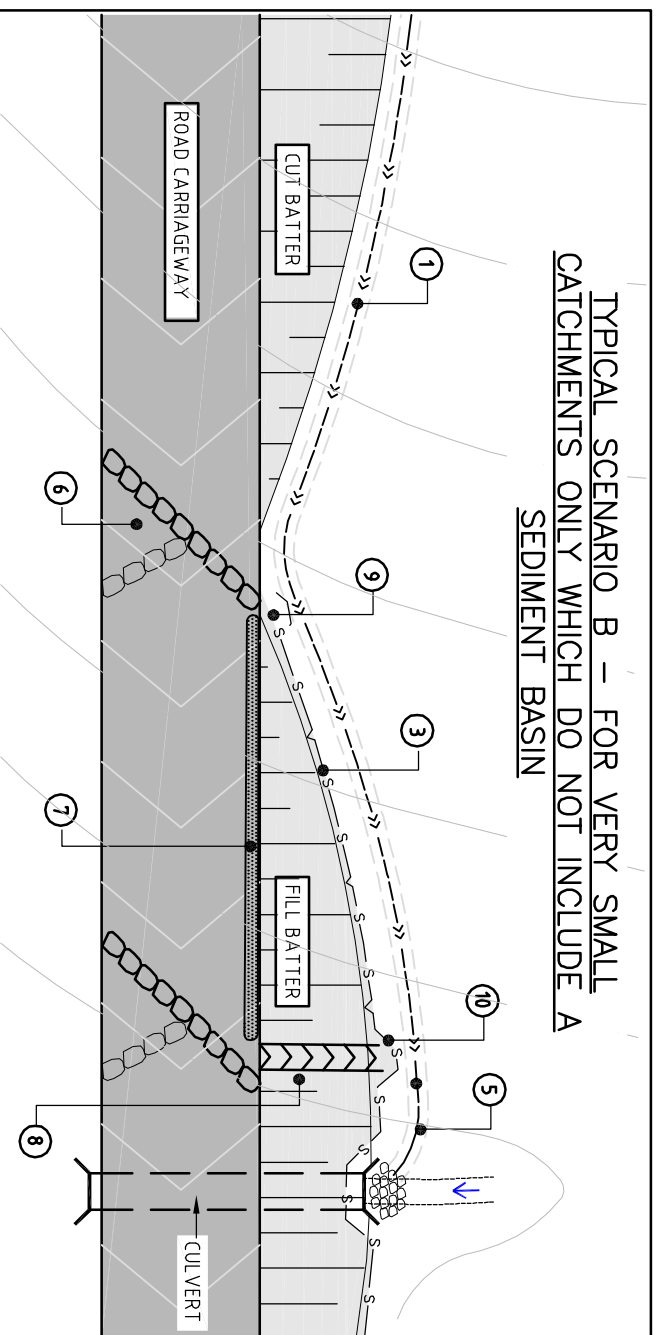
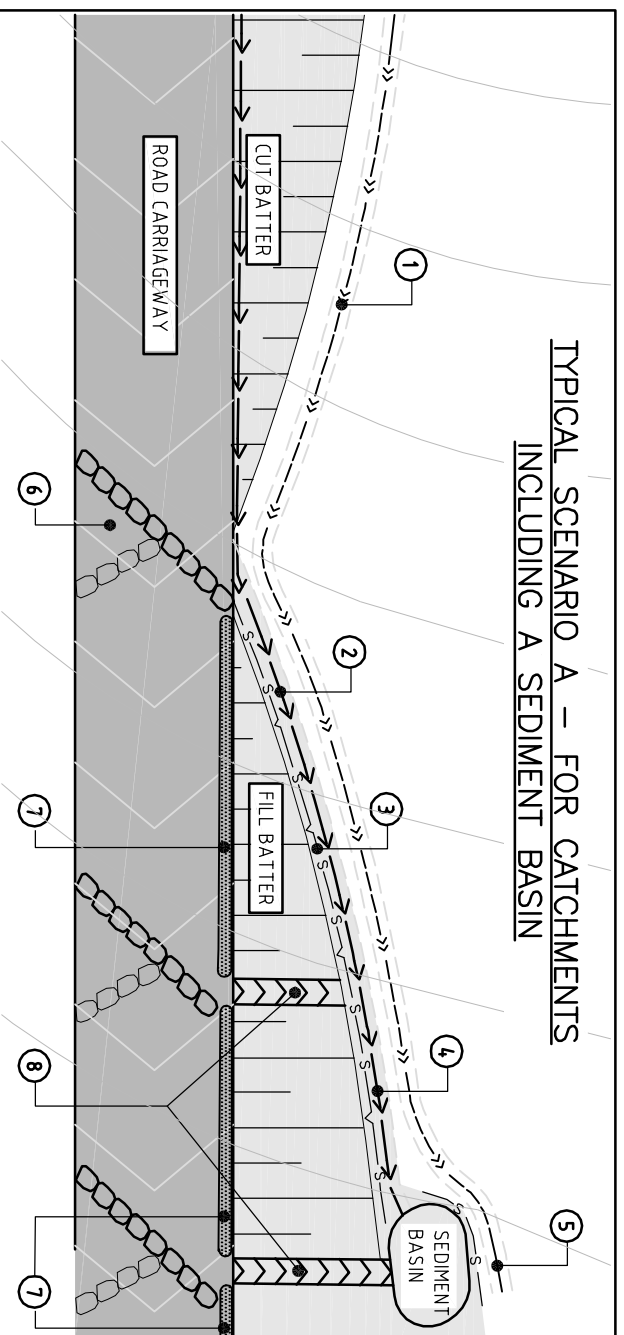

CONSTRUCTION NOTES

THE FOLLOWING WORKS ARE TO BE UNDERTAKEN AS SHOWN ON THE RELEVANT DIAGRAMS

- Lined permanent diversion drains to be used as 'offsite' water drains during construction. Must convey water all the way to a watercourse or depression and onto a stabilised outlet point.
- Provide sufficient room between toe of fill and 'offsite' water drain for management of 'onsite' water. 'Onsite' water diversion (temporary drain) - to drain to sediment basin. Sediment fence at toe of batter. Include returns at 20m intervals.
- 'Onsite' water diversion (temporary drain) - to drain to sediment basin.
- Ensure 'offsite' water drain extends all the way to drainage line and onto a stabilised outlet point.
- Use earth bank or sandbags to divert runoff at cut / fill line to onsite drain or sediment trap. Do not mix with 'offsite' water in cut-off drain. Use arrowhead shape if water is being shed from both sides of formation. It is only required at end of day or when rain is imminent.
- Earth or sandbag windrow for directing water into drop-down flume. To be installed at end of day or when rain is imminent.
- Lined drop-down chute to carry 'onsite' water to basin or trap. Only required when rain is imminent.
- Install sediment trap at cut/fill line if runoff is not flowing to a basin.
- Install sediment trap at base of drop-down flume if runoff is not flowing to a basin. This can simply be formed as a section of the sediment fence with returns both sides.

TYPICAL SCENARIO B – FOR VERY SMALL CATCHMENTS ONLY WHICH DO NOT INCLUDE A SEDIMENT BASIN

AT ALL TIMES DURING WORKS, ENSURE THAT 'OFFSITE' WATER IS PASSED AROUND OR THROUGH THE SITE WITHOUT COMING INTO CONTACT WITH EXPOSED SOIL OR 'ONSITE' WATER

NOTE THAT NOT ALL ONSITE WATER MANAGEMENT AND SEDIMENT CONTROLS ARE SHOWN HERE.

ONLINE PIPE REPLACEMENT/INSTALLATION – SMALL INTERMITTENT DEPRESSIONS ONLY (PUMP OPTION)

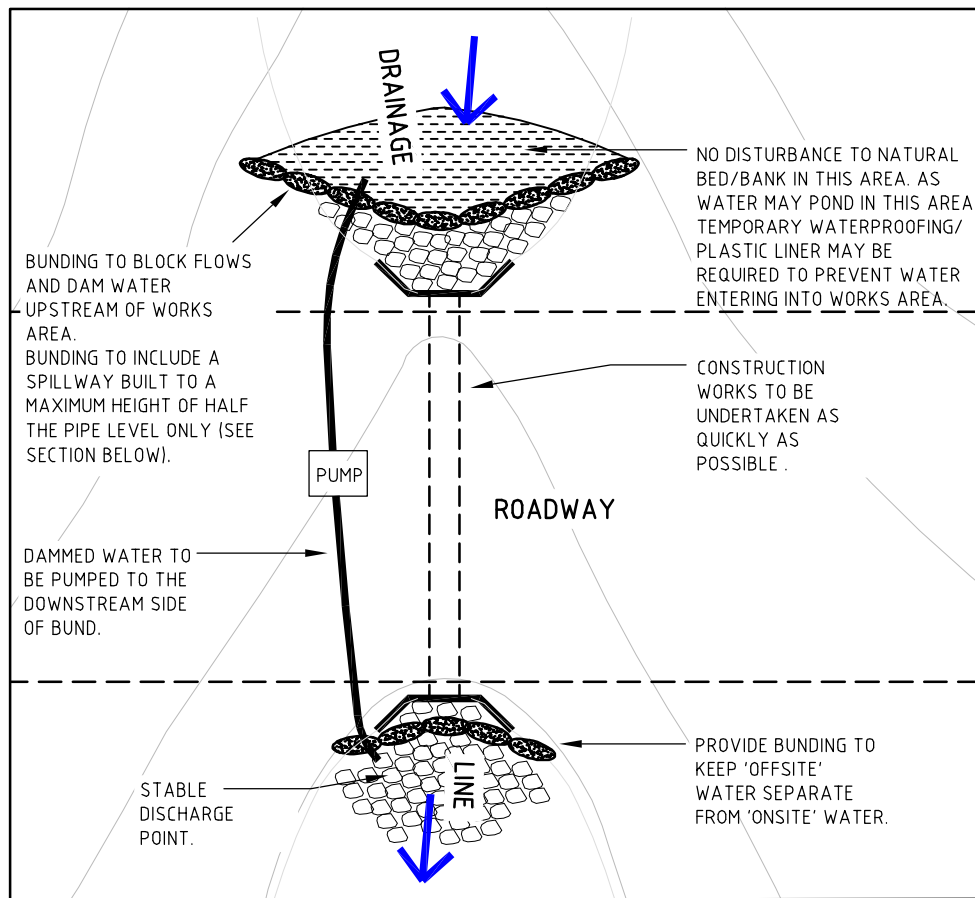

SITE STABILISATION

THIS METHOD IS ONLY SUITABLE FOR SIMPLE DEPRESSIONS WITH INTERMITTENT FLOWS. TO BE IN PLACE FOR NO MORE THAN 3 MONTHS.

CONSTRUCTION NOTES

WORKS TO BE UNDERTAKEN IN THE ORDER GIVEN BELOW

1. Ensure suitable temporary groundcover materials (e.g. geofabric, blankets) are located on site.
2. Ensure a suitable pump is available.
3. Watch the weather forecast to ensure rainfall is not forecast and monitor creek flows ensuring flows are minimal.
4. Position the bunding and line if required.
5. Undertake construction works (including inlet and outlet stabilisation) as quickly as possible. Drainage line to be blocked for no more than 3 months.

At any time during steps 4 - 5 where a significant rain or flow event is forecast or if the site is left unattended for prolonged periods temporary groundcover should be applied to all exposed soils in the works area.

LEGEND

	OFFSITE WATER DIVERSION DRAIN (SD 5-6)
	ONSITE WATER DRAINS (SD 5-6)
	SURFACE CONTOURS
	ROCK STABILISED OUTLET (SD 5-8)
	CREEK/PIPE FLOW ROUTE
	SEDIMENT FENCE (SD 6-8)
	BUNDS

NOTE THAT NOT ALL ONSITE WATER MANAGEMENT AND SEDIMENT CONTROLS ARE SHOWN HERE.

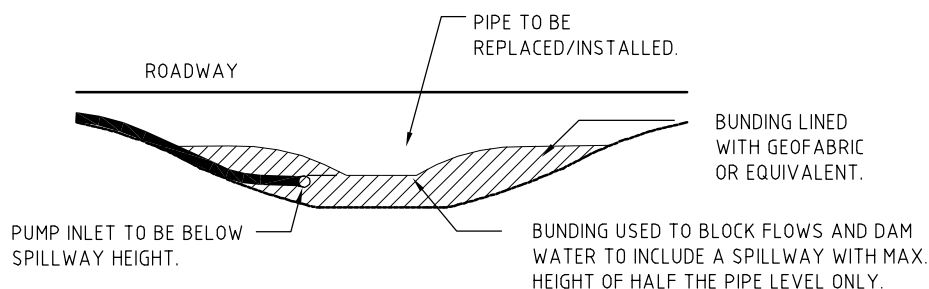

SECTION THROUGH BUNDING LOCATION

AT ALL TIMES DURING WORKS, ENSURE THAT 'OFFSITE' WATER IS PASSED AROUND OR THROUGH THE SITE WITHOUT COMING INTO CONTACT WITH EXPOSED SOIL OR 'ONSITE' WATER

ONLINE PIPE REPLACEMENT/INSTALLATION – SMALL INTERMITTENT DRAINAGE LINES (TEMPORARY PIPE OPTION)

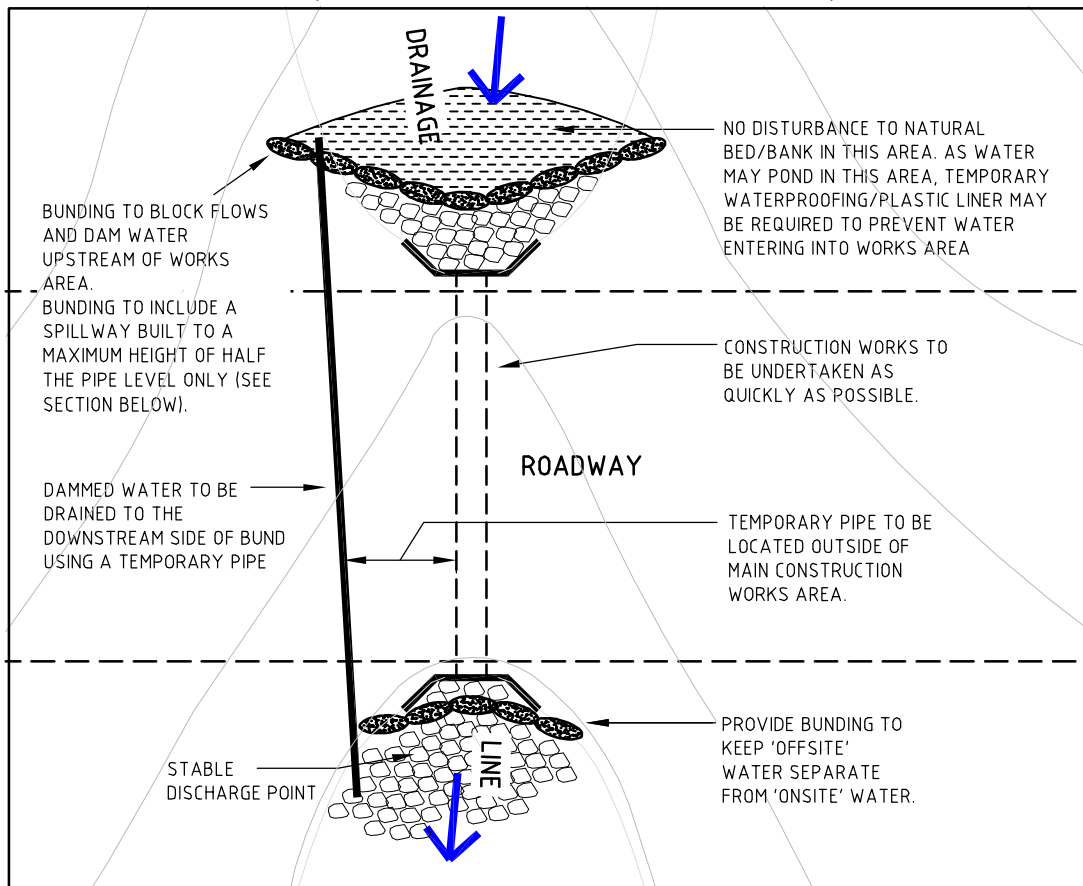

BUNDING TO BLOCK FLOWS AND DAM WATER UPSTREAM OF WORKS AREA.
BUNDING TO INCLUDE A SPILLWAY BUILT TO A MAXIMUM HEIGHT OF HALF THE PIPE LEVEL ONLY (SEE SECTION BELOW).

DAMMED WATER TO BE DRAINED TO THE DOWNSTREAM SIDE OF BUND USING A TEMPORARY PIPE

NO DISTURBANCE TO NATURAL BED/BANK IN THIS AREA. AS WATER MAY POND IN THIS AREA, TEMPORARY WATERPROOFING/PLASTIC LINER MAY BE REQUIRED TO PREVENT WATER ENTERING INTO WORKS AREA

CONSTRUCTION WORKS TO BE UNDERTAKEN AS QUICKLY AS POSSIBLE.

TEMPORARY PIPE TO BE LOCATED OUTSIDE OF MAIN CONSTRUCTION WORKS AREA.

PROVIDE BUNDING TO KEEP 'OFFSITE' WATER SEPARATE FROM 'ONSITE' WATER.

SITE STABILISATION

THIS METHOD IS ONLY SUITABLE FOR SMALL CHANNELS WITH INTERMITTENT FLOWS.

TEMPORARY PIPE TO BE SIZED TO AT LEAST HALF THE PERMANENT PIPE.

e.g. - PERMANENT: 600 ϕ
- TEMPORARY: MINIMUM 300 ϕ

THIS METHOD (TEMPORARY PIPE SYSTEM) WILL NOT BE SUITABLE IN STEEP LOCATIONS WHERE TEMPORARY PIPE CANNOT BE LOCATED OUTSIDE OF WORKS AREA.

LEGEND

- OFFSITE WATER DIVERSION DRAIN (SD 5-6)
- ONSITE WATER DRAINS (SD 5-6)
- SURFACE CONTOURS
- ROCK STABILISED OUTLET (SD 5-8)
- CREEK/PIPE FLOW ROUTE
- SEDIMENT FENCE (SD 6-8)
- BUNDS

NOTE THAT NOT ALL ONSITE WATER MANAGEMENT AND SEDIMENT CONTROLS ARE SHOWN HERE.

CONSTRUCTION NOTES

WORKS TO BE UNDERTAKEN IN THE ORDER GIVEN BELOW

1. Ensure suitable temporary groundcover materials (eg. geofabric, blankets) are located on site.
2. Ensure a temporary pipe is available. Install temporary pipe to ensure flow, preferably by providing continuous fall.
3. Watch the weather forecast to ensure rainfall is not forecast and monitor creek flows ensuring flows are minimal.
4. Position the bunding within the channel to secure the site.
5. Undertake construction works (including inlet outlet stabilisation) as quickly as possible.

At any time during steps 4 - 5 where a significant rain or flow event is forecast or if the site is left unattended for prolonged periods temporary groundcover should be applied to all exposed soils in the works area.

AT ALL TIMES DURING WORKS, ENSURE THAT 'OFFSITE' WATER IS PASSED AROUND OR THROUGH THE SITE WITHOUT COMING INTO CONTACT WITH EXPOSED SOIL OR 'ONSITE' WATER

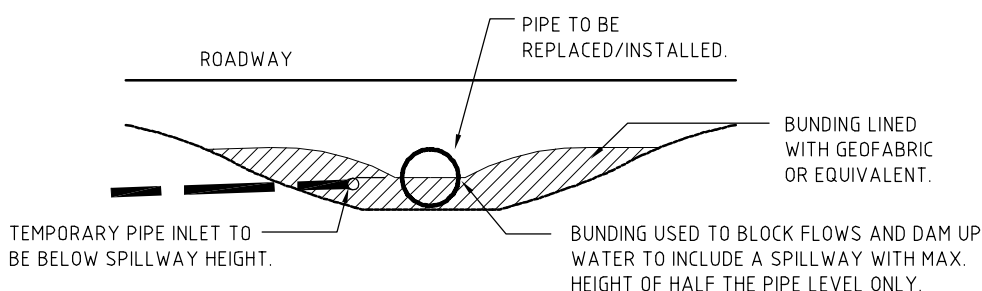

SECTION THROUGH BUNDING LOCATION