

Transport
for NSW

Safety features and technologies for heavy vehicles

transport.nsw.gov.au

March 2024



Contents

Introduction	1		
Crash Avoidance Technologies	3		
1 Electronic Stability Control (ESC) System	3		
2 Trailer Roll Stability (TRS) System	4		
3 Autonomous Emergency Braking (AEB) System	4		
4 Autonomous Reverse Braking (ARB) System	5		
5 Autonomous Emergency Braking (AEB) Nearside turn	5		
6 Autonomous Emergency Braking (AEB) Turn Across	6		
7 Electronic Braking System (EBS)	6		
8 Anti Jack-Knife Braking	7		
9 Electronic Brake Distribution (EBD) System	7		
10 Load-Proportioning Brake Valve (LPBV) System	8		
11 Adaptive Cruise Control (ACC) System	8		
12 Driver Fatigue Monitoring System	9		
13 Wheel Nut	9		
14 Wheel Nut Indicators and Locks	10		
15 Antilock Braking Systems (ABS)	10		
16 Disc Brakes	11		
17 Lane Departure Warning System (LDWS)	11		
18 Lane Keeping Assist (LKA)	12		
19 Daytime Running Lamps (DRL)	12		
20 Blind Spot Elimination / Enhanced Daytime Vision System	13		
21 Enhanced Night Vision (ENV) System	13		
22 Adaptive Headlamps	14		
23 Cornering Lamps	14		
24 Light Emitting Diode (LED) Lighting	15		
25 Emergency Stop Light	16		
26 Enhanced Vehicle Visibility Markings	16		
27 Tyre Pressure Management Devices	17		
28 Tyre Puncture Prevention and Tyre Inflation	17		
29 Connected Vehicle Technologies	18		
30 High Intensity Discharge (HID) Headlamps with Levelling System	18		
31 Automatic Traction Control (ATC) System	19		
32 Reversing Safety Systems	19		
33 Spray Suppression Devices	20		
34 Roll Away Emergency Parking Brake System	20		
35 Alcohol Ignition Interlocks	21		
36 Acoustic Vehicle Alerting System (AVAS)	21		
37 Motion Inhibit	22		
Protective Technologies	23		
38 Suspension Seats with Integrated Seatbelts	23		
39 Seatbelts for Buses	23		
40 Rear Underrun Protective Devices (RUPDs)	24		
41 Side Underrun Protective Devices (SUPDs)	24		
42 Front Underrun Protective Devices (FUPDs)	24		
43 Supplementary Restraint System (SRS) Airbag	25		
44 Rollover Side Curtain Airbag	25		
45 Cabin Strength Standards	26		
46 Seatbelt Wearing Monitors	26		
47 Automatic Brake Adjustment (ABA) Devices	26		
General Safety	27		
48 Electricity Line Proximity Warning Devices	27		
49 In-Cabin Noise Quality	28		
50 Driver Ride Quality	28		
51 Ergonomic Cabin Design	29		
52 Tipper Safety Systems	29		
53 Tipping-Trailer Stability Protection System	30		
54 Intelligent Speed Adaptation (ISA) Warning System	30		
55 Fire Suppression Systems	31		
56 Automatic Crash Notification (ACN) System	31		
57 Wheel Temperature Monitoring	32		
58 Field of View	32		
59 Fresnel Lens	33		
60 Mirrors	34		
61 Onboard Weighing System	35		
62 Emergency Hatch	35		

Introduction

Heavy vehicle safety is a serious issue in New South Wales. While their numbers make up only 2.5 per cent of NSW motor vehicle registrations and 9.8 per cent of kilometres travelled within NSW, heavy vehicles are involved in around 18 per cent of all road fatalities. This is not to say they are always the at fault vehicle, but their size and mass make any crash a serious one.

Improvements to heavy vehicle design and safety features have made a proven contribution to reducing the number and severity of crashes.

The Centre for Road Safety in Transport for NSW independently reviews a wide range of crash avoidance and vehicle technologies available in the market. Every technology described in this publication has a safety benefit.

Some technologies have additional benefits such as improving driver and passenger comfort. Some of the more advanced technologies come at a cost but many are inexpensive and practical to install and must meet Australian Design Rule requirements, including any required assessment and certification for any significantly modification by an Approved Vehicle Examiner. Approximately half of these recommended features can be retrofitted to a heavy vehicle.

Under the Road Safety Action Plan 2026, the NSW Government is working with the heavy vehicle industry to support smarter safer vehicle design and technologies with lifesaving features and encourage more people to choose the safest vehicle.

When purchasing your next heavy vehicle, be it new or used, or making after-market improvements consider your safety and that of other road users – the technology may save a life!

The range of technologies are categorised by type:

- ▶ Crash avoidance
- ▶ Protection systems
- ▶ General safety.

Research suggests that if all heavy vehicles were fitted with Autonomous Emergency Braking fatal heavy vehicle crashes would be **reduced by**

↓ **25%**

(see page 4 for further details)

Research suggests that if all heavy vehicles were fitted with Lane Departure Warning fatal heavy vehicle crashes would be **reduced by**

↓ **6%**

(see page 11 for further details)

Research suggests that if all heavy vehicles were fitted with Electronic Stability Control fatal heavy vehicle crashes would be **reduced by**

↓ **4%**

(see page 3 for further details)

Heavy vehicles on NSW roads

With the increase in freight task and traffic on our roads, heavy vehicles are facing more challenges. Adopting safety technologies and features in our fleets ensures our heavy vehicle drivers are safer and also helps decrease serious injuries and fatalities on NSW roads.

Heavy vehicles represent **2.5%** of all registered motor vehicles in NSW and

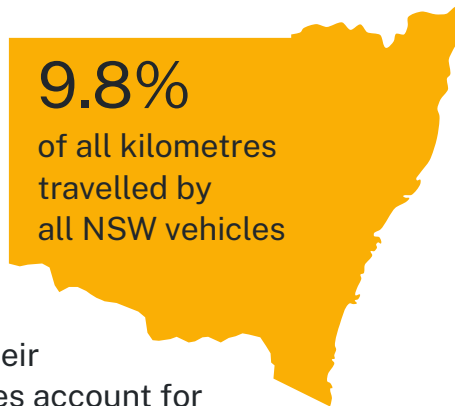
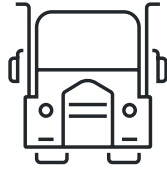

But their crashes account for **18%** of all fatalities in NSW

Fatalities 2013–2022, type of crash

Crash does not involve a heavy vehicle (2700)

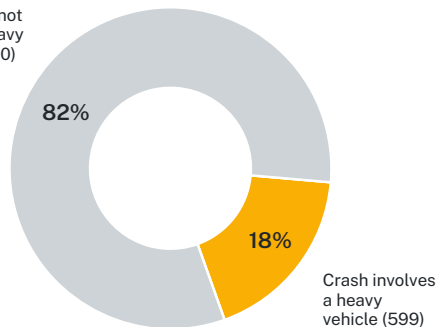

Fatalities from heavy truck crashes 2013–2022, type of crash

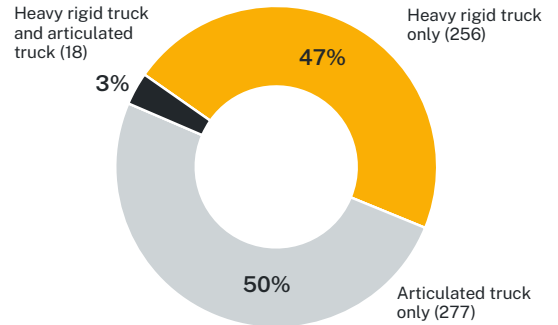

Heavy vehicle crashes 2013–2022, degree of crash

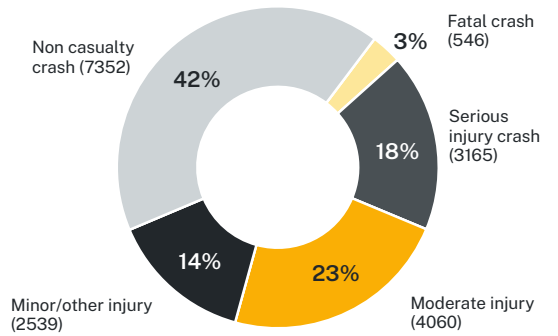

Articulated truck crashes 2013–2022, degree of crash

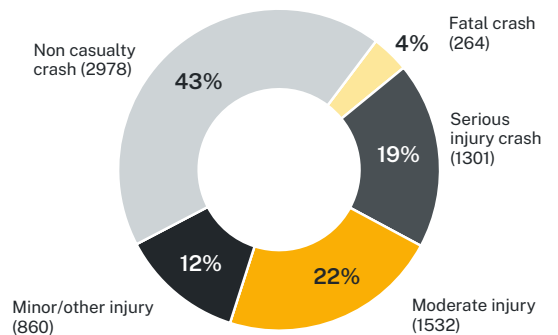

Heavy rigid truck crashes 2013–2022, degree of crash

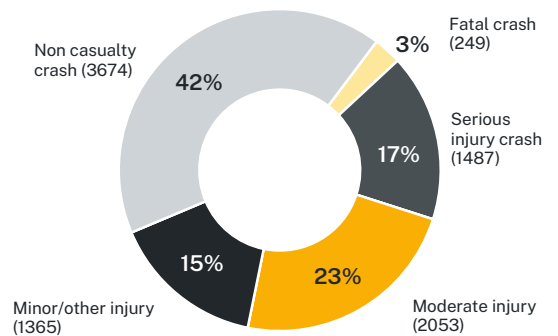

Crash Avoidance Technologies

Crash avoidance features are safety technologies that assist the driver to reduce the likelihood of a crash. They include the following technologies you should consider when purchasing your next heavy vehicle or making after-market improvements.

1 Electronic Stability Control (ESC) System

By applying braking to selected wheels (and the trailer wheels if one is being towed), an ESC system assists to correct a deviation from the driver's desired course. The ESC system assesses the driver's intended path and compares it with the actual direction by monitoring the driving inputs (throttle, braking level and steering angle) and the vehicle's performance (lateral deceleration, yaw deceleration and wheel speeds).

An ESC system is potentially effective in situations where there is a loss of directional control and can help avoid rollover crashes. To minimise trailer swing when braking severely, it is recommended trailers attached to a towing vehicle with an ESC system have ABS (see technology 15). ESC is strongly recommended when purchasing a new vehicle as it cannot be retrofitted cost effectively.

Research suggests that ESC fitted to heavy vehicles may prevent around 4 per cent of fatal heavy vehicle crashes.

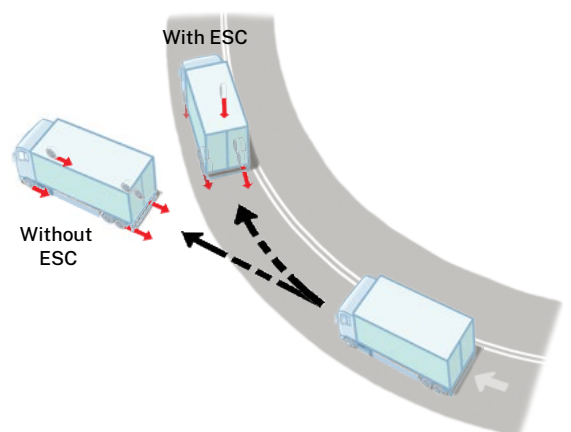

2 Trailer Roll Stability (TRS) System

A TRS system can predict a rollover threshold and the critical speed at which this could occur by monitoring wheel speeds, weight distribution between the trailer's sides, actual lateral acceleration and air suspension pressures.

When the actual speed approaches the critical speed, the TRS system applies the brakes and slows the trailer down to prevent rollover. The TRS system is a standard feature and can be retrofitted as one element of Electronic Brake Distribution (see technology 9) available for trailers in Australia.

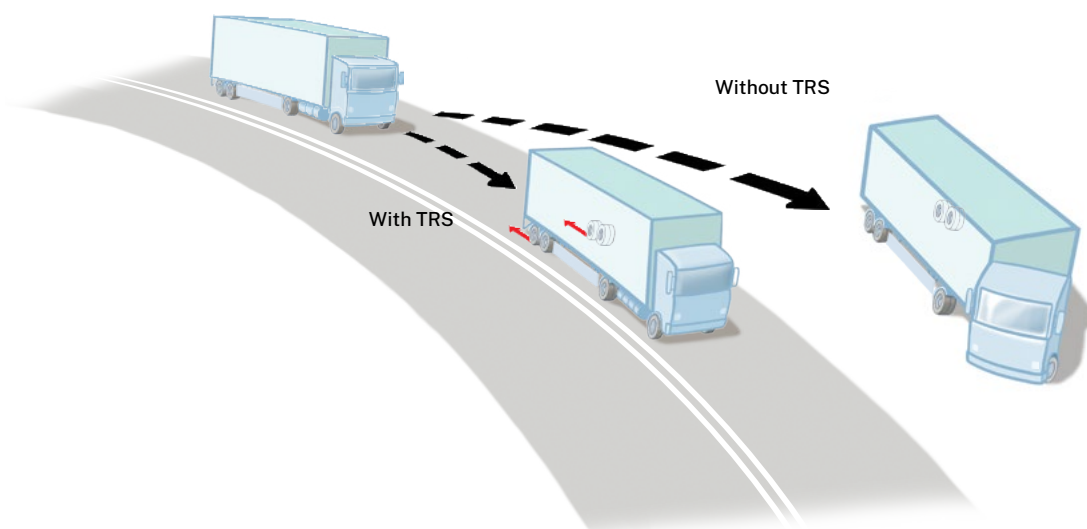

3 Autonomous Emergency Braking (AEB) System

An AEB system will provide warning to the driver and apply braking when a crash threat is detected immediately in front of the vehicle. The detection system uses radar and/or optical sensors and is normally coupled with other forward sensing radar or optics vision processing technology such as Adaptive Cruise Control (see technology 11) and Lane Departure Warning System (see technology 17).

AEB technology is very effective for minimising crashes with vehicles travelling in the same direction. To avoid trailer swing when braking

severely, trailers attached to a towing vehicle with an AEB system are recommended to have Antilock Braking Systems (see technology 15). This system cannot be retrofitted cost effectively.

Some advance systems are also capable of detecting and protecting vulnerable road users such as pedestrians and cyclists.

Research suggests that AEB fitted to heavy vehicles may prevent around 25 per cent of fatal heavy vehicle crashes.

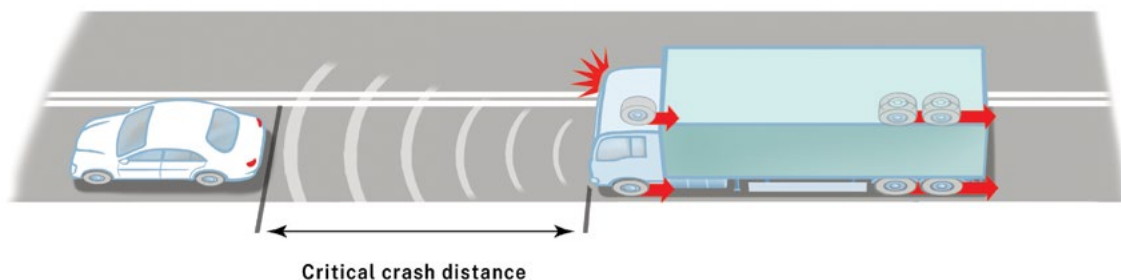

4 Autonomous Reverse Braking (ARB) System

An ARB system functions while the vehicle is reversing. The system detects an object, including a pedestrian, and applies braking when a crash threat is detected immediately behind the vehicle.

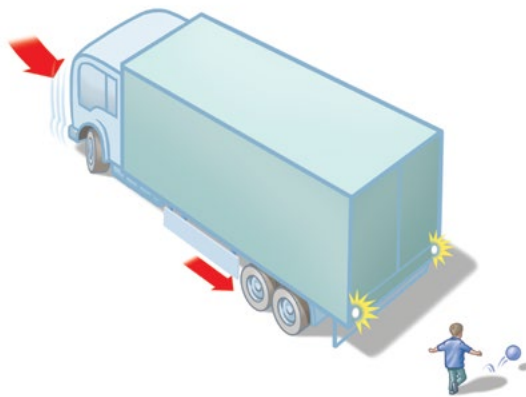

The detection system uses radar and/or optical sensors to provide warning to the driver and if no action is taken autonomously provides braking. ARB is very effective for minimising crashes while reversing. This system can be retrofitted and can be applied to both rigid vehicles and combinations.

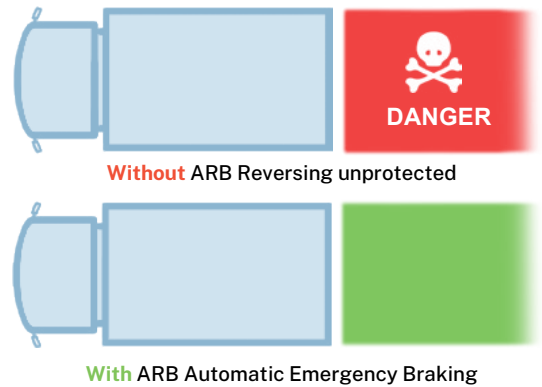

5 Autonomous Emergency Braking (AEB) Nearside turn

Due to their weight and size, trucks can have bigger blind spots than other vehicles. Trucks have four main blind spots: at the front, rear and sides of the vehicle.

Blind spots can pose a high risk for road users in the close vicinity of a heavy vehicle. A turning heavy vehicle is of particular risk to cyclists and pedestrians who may be in or near the blind spot as the truck is turning.

AEB Nearside turn safety feature utilises sensors with a wide field of view to detect the presence of vulnerable road users near the side of the vehicle. It acts by providing individual or combined inputs to the steering or braking to avoid a crash. This technology helps to address the risk of a sudden potential crash in urban areas by providing a system which can intervene with potentially reduced reaction time.

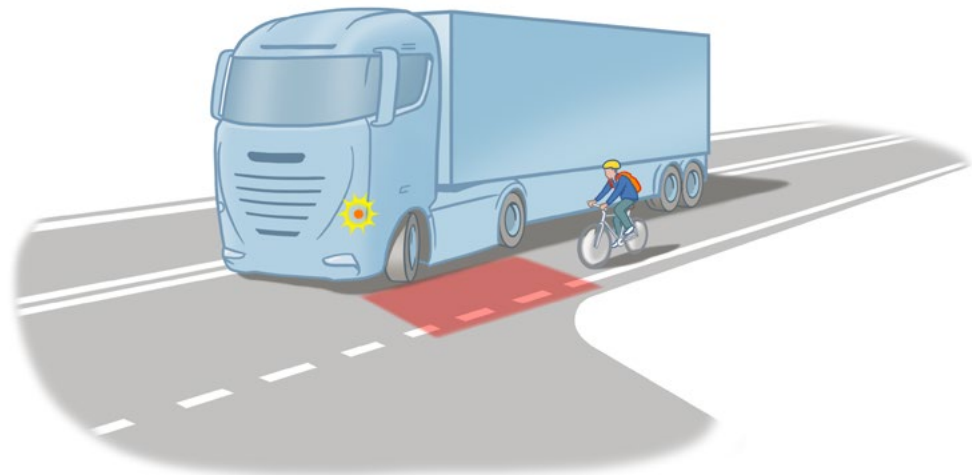

6 Autonomous Emergency Braking (AEB) Turn Across

AEB Turn Across systems allow a turning vehicle to detect oncoming traffic using sensors such as radar, lidar and cameras which cover a wide field of view. The sensors will warn the driver of the risk of a crash if it determines the vehicle is on course to impact with oncoming traffic. The system will also prevent the vehicle from proceeding to prevent a crash.

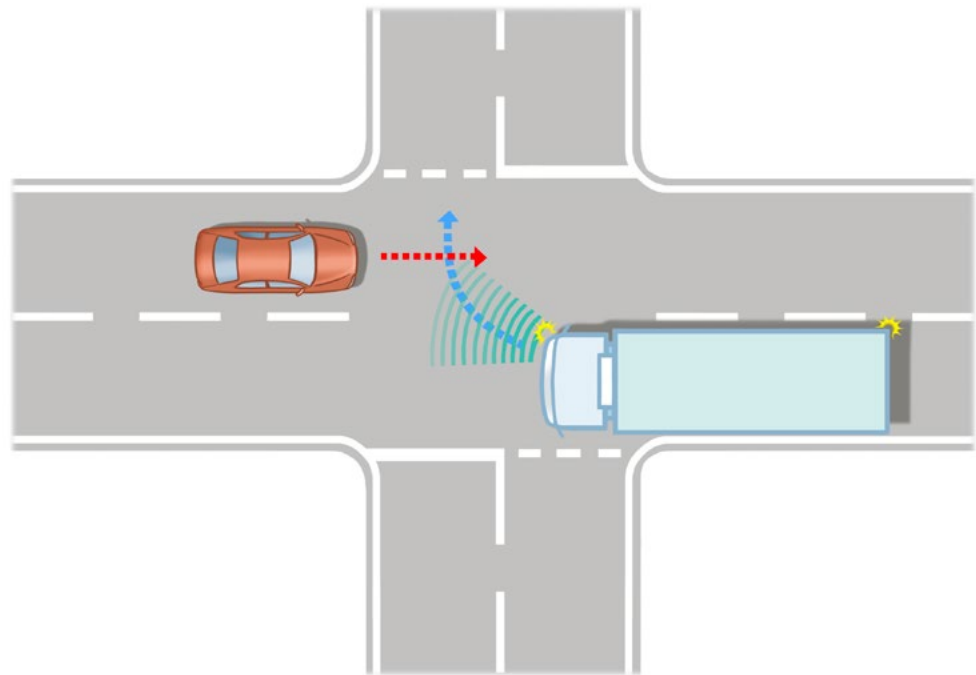

7 Electronic Braking System (EBS)

Electronic Braking Systems use electronic signals, as opposed to conventional air signals. These signals are transmitted, as normal, by application of the brake pedal. This improves both stopping distances and braking system performance.

EBS provides instantaneous brake response with immediate application and release in direct proportion to pedal pressure. Due to the fast and simultaneous brake release it helps to overcome brake drag that may happen when the brakes release momentarily later on some axles than on other axles, and therefore it also helps to save fuel. The longer the vehicle combination, the greater safety benefits EBS provides.

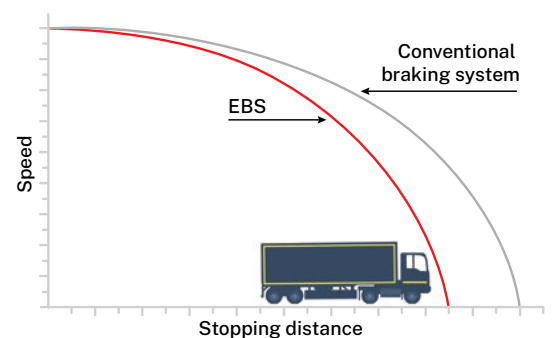

8 Anti Jack-Knife Braking

Anti jack-knife braking provides improved stability and braking in situations such as cornering or driving downhill on a slippery road. The system pulses the trailer's brakes, providing trailer retardation, and in turn causing the vehicle

combination to stretch. This reduces the risk of the trailer pushing the hauling unit and folding the combination. The system can be automatically activated to improve the stability of the combination at speeds up to 50 km/h.

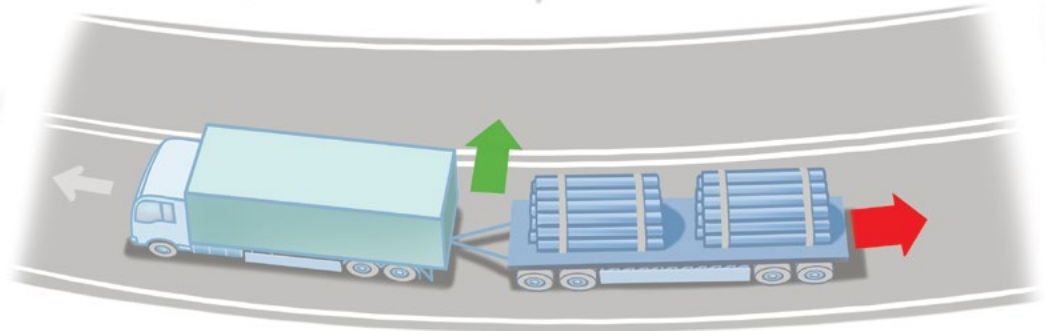

9 Electronic Brake Distribution (EBD) System

An EBD system provides improved braking balance by adjusting braking pressure between the front and rear axle groups according to their weight distribution. Because an EBD system operates well before wheel lock-up occurs (by monitoring the average wheel slips between sensed wheels in the axle groups), EBD technology is like an enhanced Antilock Braking Systems (see technology 15).

It is particularly effective when applied to an unladen trailer whose axles are prone to lock-up due to the proportionately lower axle loads if no brake balance systems are installed. It is important that a trailer attached to a towing vehicle with an EBD system has Antilock Braking Systems to avoid trailer swing when braking severely. This system can be retrofitted, but is usually more cost effective when purchased as a feature in a new vehicle.

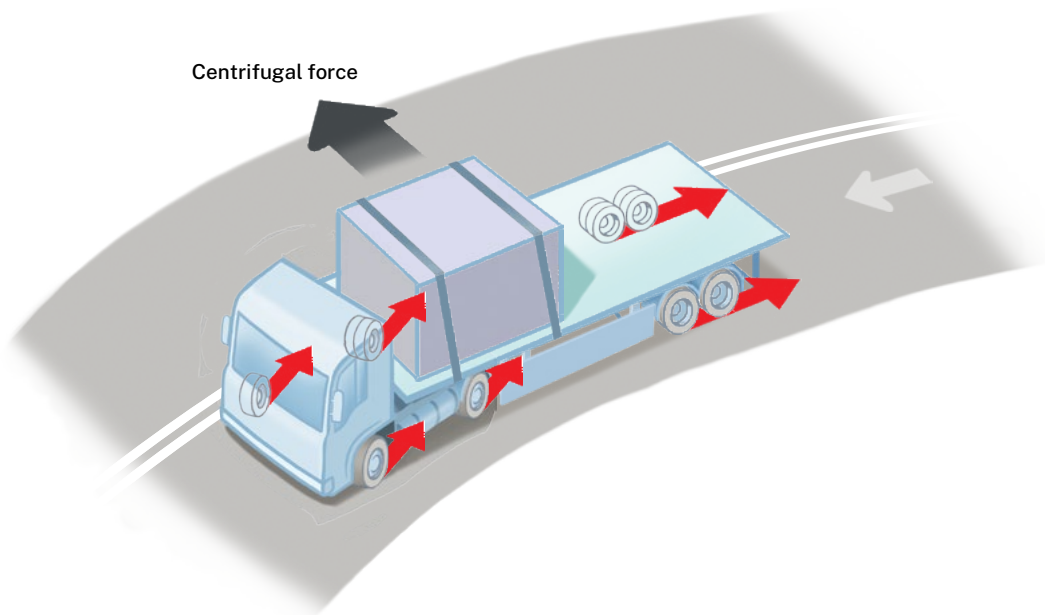

10 Load-Proportioning Brake Valve (LPBV) System

Similar to EBD systems (see technology 9), the LPBV system improves a vehicle's brake balance on vehicles with air-spring suspension. An LPBV system typically measures the average air pressure in two selected air springs and varies the air pressure applied to the brake actuators to keep the braking level proportional to the vehicle's weight distribution. Although it is not an electronic system, an LPBV system can work well

in conjunction with ABS. An LPBV system will offer greater improvement in braking balance if fitted to all vehicle units in the combination, particularly combinations that include very light-weight trailers such as aluminium bodied tankers and dog trailers. Vehicles with airbag suspension systems are easier to retrofit than vehicles with mechanical suspension systems.

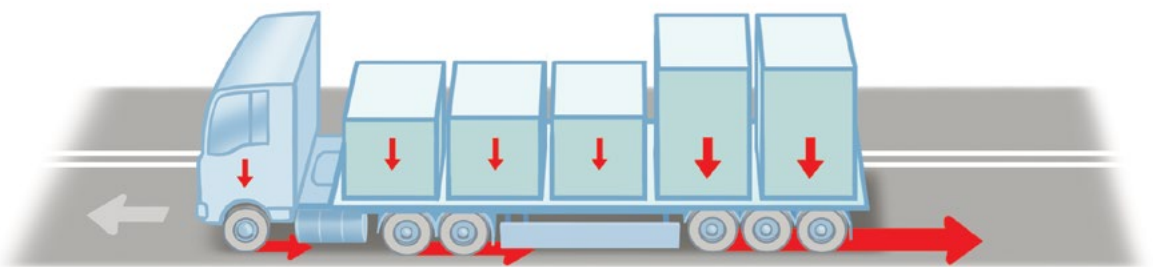

11 Adaptive Cruise Control (ACC) System

An ACC system can automatically adjust a vehicle's speed to a preset following distance. It does this by regulating engine power and applying the service brakes when required in order to maintain the preset distance.

Sensors fitted on the front of the heavy vehicle use radar signals and/or optical image processing to determine vehicle speeds and maintain the preset following distance.

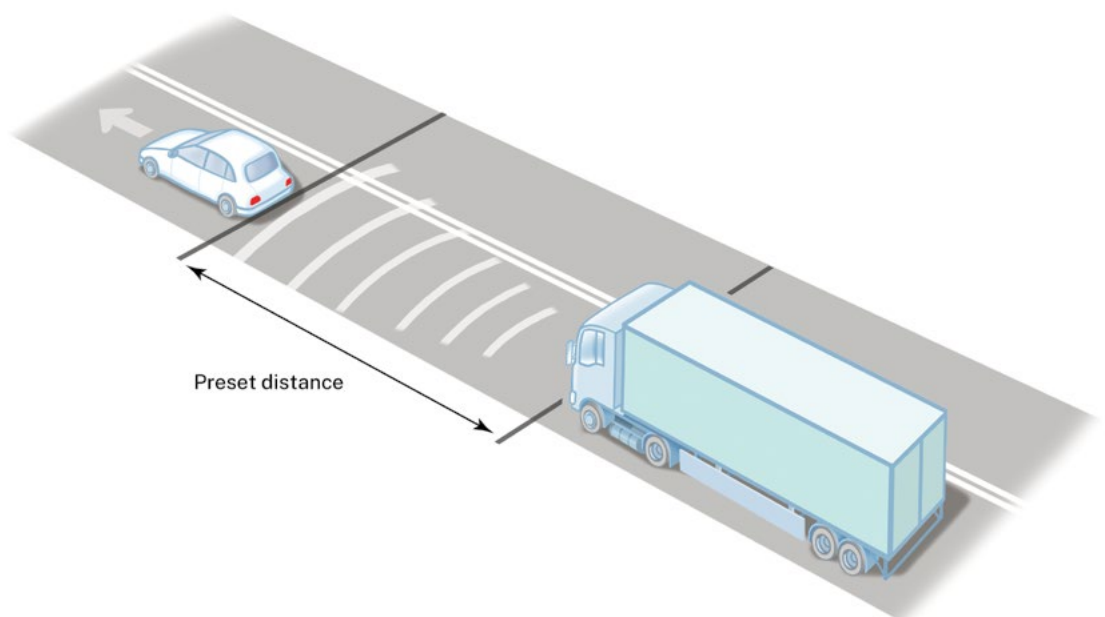

12 Driver Fatigue Monitoring System

Various technologies are currently available for drivers to prevent driver fatigue. Vehicle performance systems include steering wheel movement and lane positioning monitors; physiological systems use sensors to monitor the driver's eye movement, head orientation, brain activity, heart rate and skin conductance.

Eye monitoring systems can include a camera mounted in the cabin of the vehicle, or special glasses worn by the driver. Another wearable driver fatigue monitoring technology is a band that is worn around the driver's wrist. This

device monitors the driver's sleep behaviour and predicts the likely onset of fatigue. Eye monitoring cameras are also available as an app for smartphones. Some eye and head monitoring systems also provide driver distraction warnings.

The technology continues to evolve and it may soon appear as an integrated system by the original equipment manufacturers. Research suggests the use of fatigue warning systems in heavy vehicles may prevent around four per cent of fatal heavy vehicle crashes.

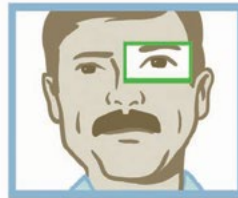

Alert



Inattentive



Drowsy

13 Wheel Nut

Specialised wheel nuts are designed to withstand extreme vibration without loosening.

The wheel nut incorporates a pair of captivated washers with cam faces on one side. The cam angle is greater than the thread pitch angle. On the opposite side of the washers there are radial teeth. When the wheel nut is tightened, the teeth of the washers grip and lock the mating

surfaces, allowing movement only across the cam faces. Any rotation of the wheel nut is blocked by the wedge effect of the cams.

The wheel nut safely secures wheels for both on-road and off-road applications by maintaining high clamping force even under extreme operating conditions.

It represents a simple and cost effective way to make wheels safe and secure for more productive and efficient operations.

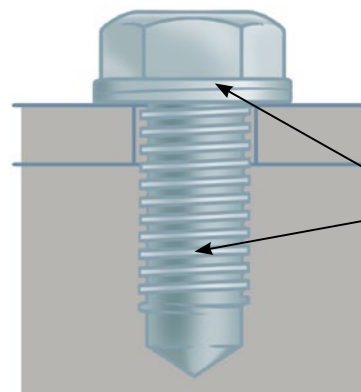

Thread angle secures bolted joints that can withstand extreme vibration without loosening

14 Wheel Nut Indicators and Locks

Checking that all wheel nuts are properly fastened prior to driving is good practice and highly advisable when wheels have been changed. Wheel nut indicators are plastic caps which can be fitted over the hexagonal heads of the wheel nuts. The way they are positioned provides a pattern which indicates whether the nuts have loosened over the course of a journey.

Wheel nut locks come in the form of a plastic strap which is shaped to fit over the wheel nuts and lock them in place. Even if the nuts loosen slightly they are prevented from coming off, preventing any wheel detachment. Installing wheel nut indicators and locks can reduce maintenance time and both can easily be retrofitted.

Some wheel nut indicators display when a wheel change has occurred and assist in identifying which wheel nuts need to be checked for correct tension.

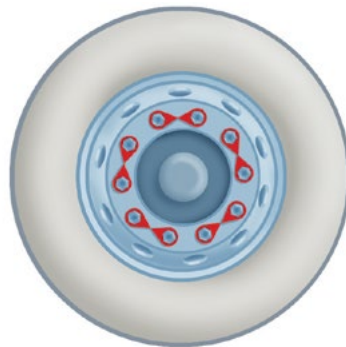

Safe

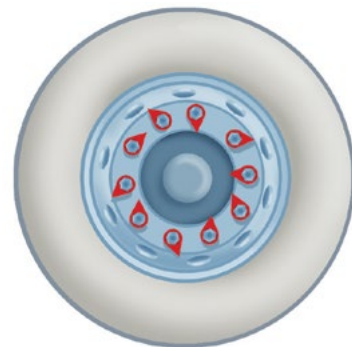

Unsafe

15 Antilock Braking Systems (ABS)

Antilock braking systems (ABS) is a system which prevents the wheels of a vehicle from locking up during severe braking. Keeping the wheels rotating means they can continue to have traction on the road, which assists the driver to maintain directional stability. In most cases, ABS assists to reduce stopping distances and improve vehicle control during severe braking on dry or slippery road conditions.

However on loose surfaces such as gravel or snowy roads, ABS may increase stopping distances because it releases the brakes intermittently to assist in maintaining directional stability.

ABS is significantly more effective when combined with other technologies such as ESC (see technology 1). ABS is recommended as a minimum safety feature when considering a vehicle purchase. ABS can be retrofitted to heavy vehicles, but is usually more cost effective when purchased with a new vehicle.

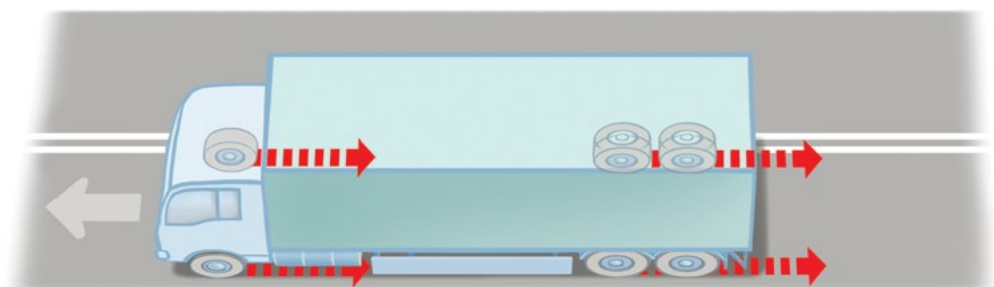

16 Disc Brakes

Disc brakes produce a much higher brake force per kilogram of brake weight in comparison to drum brakes. Importantly, disc brake performance improves as the components heat up, whereas drum brake performance deteriorates, producing potentially unbalanced braking when they are incorrectly combined on a vehicle. If used in combination with drum brakes, disc brakes tend to provide a disproportionate share of braking effort and wear out quickly, so, mixing drum and disc brakes should be avoided. While the cost of disc brake parts is generally higher, their easier maintenance and lighter weight make them a very attractive technology. Disc brakes can be retrofitted.

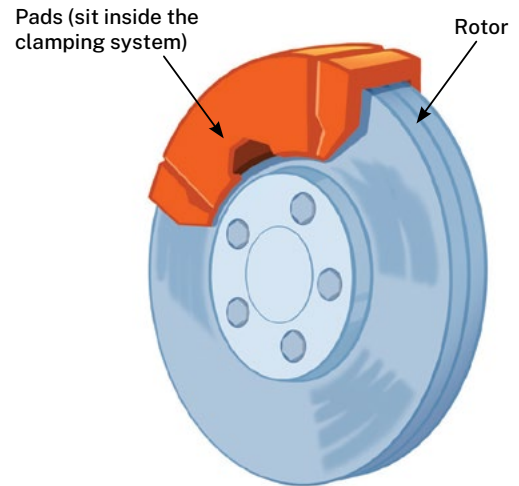

17 Lane Departure Warning System (LDWS)

LDWS offer significant safety benefits as a large number of heavy vehicle crashes involve single vehicles running off the road. An LDWS warns a driver when the vehicle unintentionally crosses a distinguishable lane boundary. The system uses optical signal processing techniques to determine the position of the vehicle within the lane as well as monitoring the driver's input through their steering and indicator use. If the driver takes no action when the vehicle wanders from the lane, the system will beep and a light will flash on the console.

Unless there is an immediate response, the system will activate a steering shudder to further alert the driver.

This system combines very effectively with an AEB system (see technology 3). An LDWS cannot function on roads where lane delineation is poor or non-existent — particularly on the left hand side of the road.

LDWS and forward collision warning can assist in fatigue and distraction monitoring by alerting a driver at the early stages of a loss of concentration. An LDWS can be retrofitted.

Research suggests that LDWS fitted to heavy vehicles may prevent around 6 per cent of fatal heavy vehicle crashes.

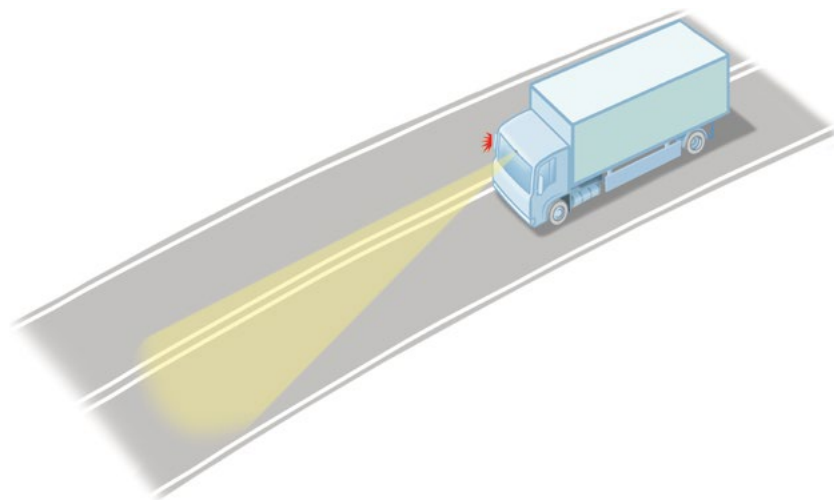

18 Lane Keeping Assist (LKA)

Lane departure warning can read lane markings and will alert you if you drift out of your lane. This can help to prevent a lane departure event.

Lane keep assist uses the same technology as lane departure warning, but with an added feature: if you do not correct your steering, it will gently steer you back into your lane. When the vehicle optics trigger a lane departure warning, and no driver corrective input is detected, an active lane keeping assist system can apply torque to the steering wheel to pull the vehicle back towards the centre of the lane. The feature will disengage when the indicator is in use.

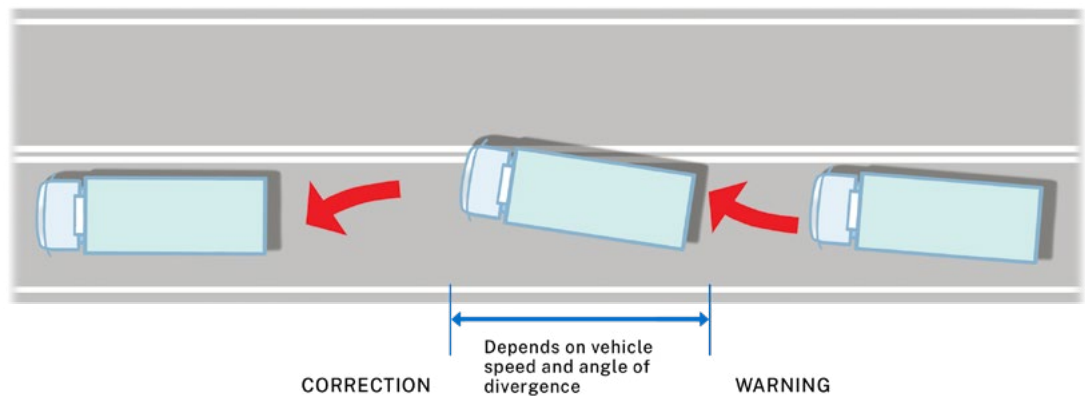
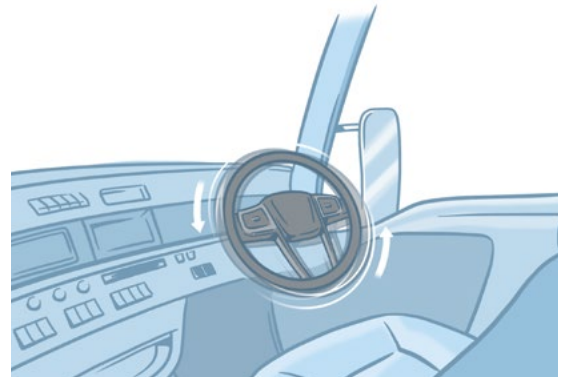

19 Daytime Running Lamps (DRL)

Daytime running lamps are forward facing white lamps, fitted to the front of vehicles. They make the vehicle more conspicuous against its background at times when headlamps are not typically switched on.

DRL automatically switch on when the engine is started and are designed to switch off when dipped-beam head lights are switched on.

Many DRL use Light Emitting Diode (LED) lighting (see technology 24) which have a low energy consumption rates compared with existing dipped-beam headlamps.

DRL increase road safety as they substantially raise the visibility of motor vehicles to other road users through a specially designed light beam pattern that controls glare and improves the extent to which the light can be seen with peripheral vision.

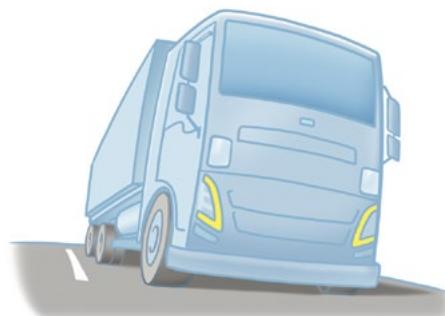

Daytime Running Lamp
(Shown in yellow for enhancement)

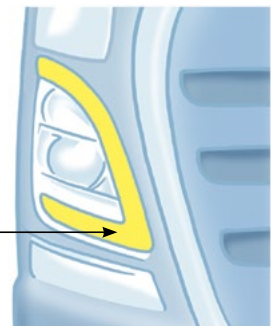

20 Blind Spot Elimination / Enhanced Daytime Vision System

A blind spot elimination system helps give the driver with a complete view of spaces around the vehicle as well as providing audible and visual warnings. This can be achieved by using a combination of extra mirrors, sensors or cameras mounted on the sides and rear of the heavy vehicle. The display screen in the cabin needs to be

unobstructed allowing the driver to access vehicle information without risking potential distraction. A good system has infra-red sensors for night time use. Some systems also operate as rear parking aid systems. Mirror and camera-based blind spot elimination systems can be retrofitted.

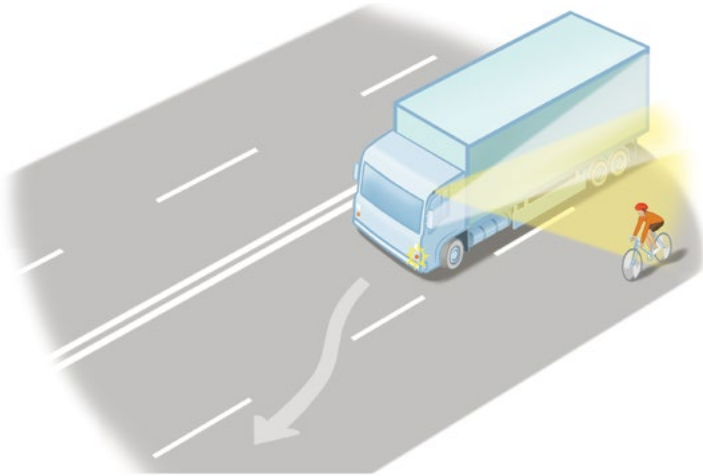

21 Enhanced Night Vision (ENV) System

An ENV system uses infra-red imaging technology to provide the driver with advance warning of approaching pedestrians, animals and cyclists. ENV achieves this by positioning forward-facing infra-red cameras on the vehicle. While offering great potential to avoid crashes by providing the driver with much more time to react, care must be taken when installing the display screen in

the cabin to provide the driver with information when desired without risking distraction. A good system would automatically alert the driver if a pedestrian, animal and/or cyclist is detected, thereby reducing the need to monitor the display frequently. ENV systems can be retrofitted.

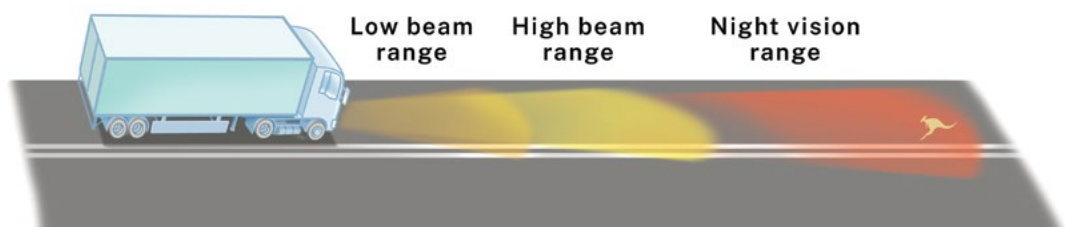

22 Adaptive Headlamps

Adaptive headlamps react to the steering, speed and elevation of the vehicle and automatically adjust to illuminate the road ahead. The lamps rotate when the vehicle is travelling around a curve, providing enhanced illumination of the road in the driver's intended course.

As the driver steers around a corner, so do the lights. This leads to a significant increase to the driver's field of vision.

Adaptive headlamps are an important safety feature for both the driver and other road users. They reduce glare to oncoming vehicles and decrease serious visibility concerns for other road users.

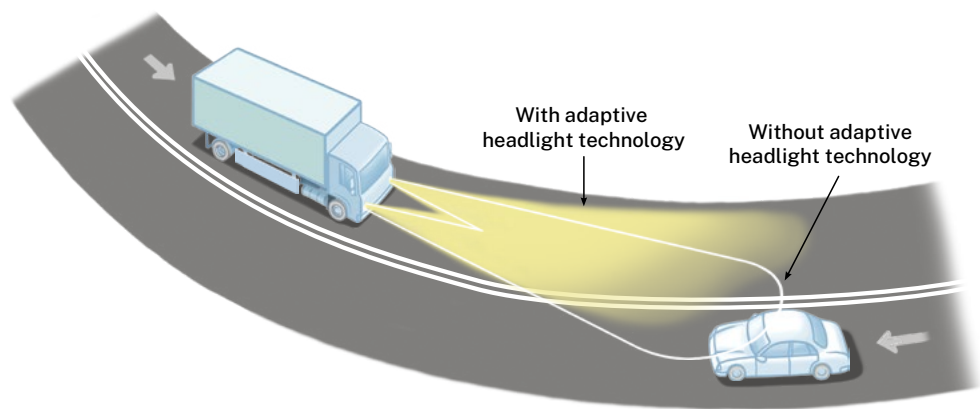

23 Cornering Lamps

Cornering lamps provide additional illumination of the area to the side of the vehicle, making night-time parking and turning safer.

Cornering lamps complement the functionality of adaptive headlamps (see technology 22). While adaptive headlamps provide superior illumination of curved roads when driving at normal speeds, cornering lights give

better lighting when carrying out low-speed manoeuvres: parking, turning into a driveway, u-turns and driving on extremely winding roads.

When the indicator is activated at low speeds, these lamps illuminate an area to the side of the vehicle, up to 80 degrees of the direction of travel.

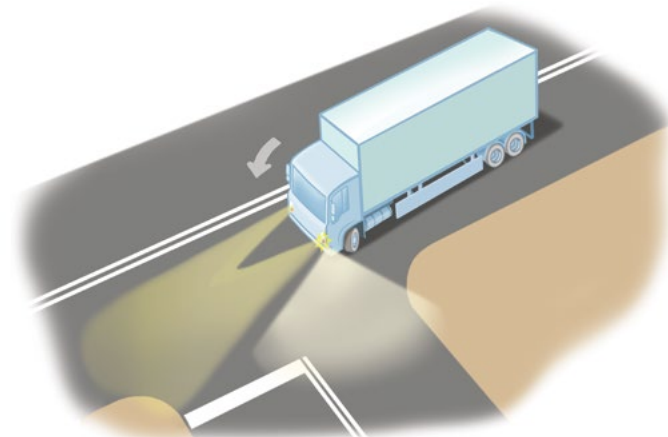

24 Light Emitting Diode (LED) Lighting

LED lighting technology offers many road safety and efficiency benefits to heavy vehicles by offering brighter and more consistent lighting at night and enhancing their visibility. LED lamps use a fraction of the power of an incandescent bulb of comparable brightness. The substantially lower electrical current draw reduces the impact of voltage drops which results in poor rear lighting particularly in longer heavy vehicle combinations.

The circuitry design on most LED lamps is compatible with a range of supply voltages which also solves the problem of voltage incompatibility of 12V and 24V equipment. LED lamps operate faster than incandescent lamps and reduce application times by up to 0.2 of a second. At 100 km/h, a 0.2 second greater response time means a significant stopping distance reduction of about 6 metres. LED lamps have proven electrical reliability that exceeds that of incandescent bulbs. LED lamps can be retrofitted.

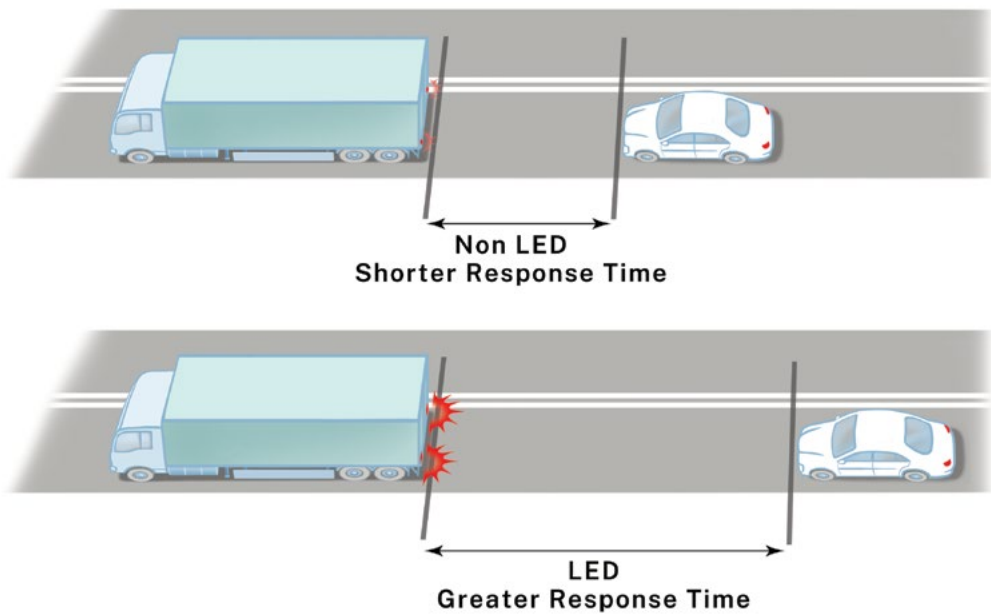

25 Emergency Stop Light

Under severe braking, the emergency stop light flashes rapidly to provide following road users with additional warning compared to conventional stop lights. The additional warning improves driver reaction times and lowers the risk of a rear-end crash.

The system operates when a truck or bus decelerates at a rate above 4 m/s^2 . The system is designed to warn drivers of the hazard ahead by allowing them to differentiate between normal and severe braking.

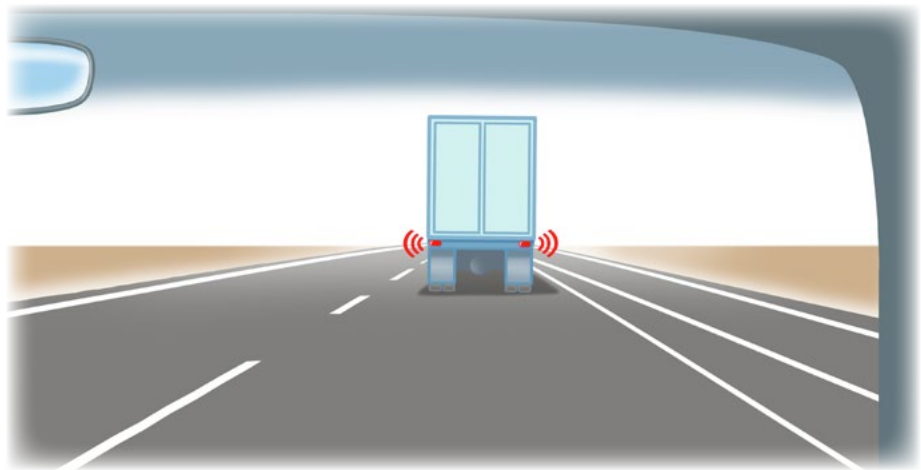

26 Enhanced Vehicle Visibility Markings

Vehicle markings increase vehicle visibility in low-light conditions, just like reflective clothing. When fitted, vehicle visibility markings must meet the optional Australian Design Rule requirements. Many older heavy vehicles in Australia suffer from poor voltage flow to the

rear lights and reflective markings aid vehicle visibility without the need for power. Vehicle visibility markings can be retrofitted. The Australian Trucking Association has developed an industry technical council advisory procedure that provides a guide to enhance vehicle visibility.

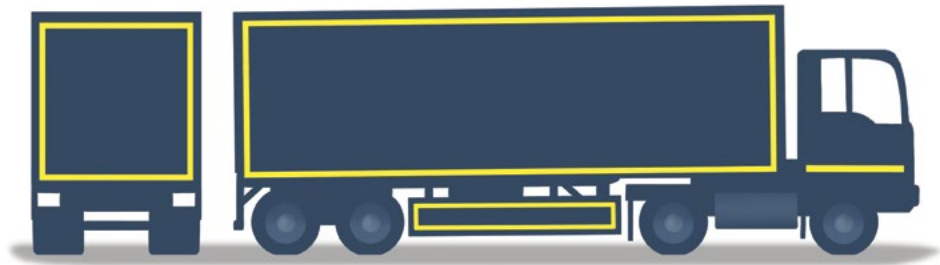

27 Tyre Pressure Management Devices

Tyres have a crucial influence on the braking and stability performance of a heavy vehicle and incorrectly inflated tyres pose a safety risk for both heavy vehicles and other road users.

A number of critical factors are dependent on the inflation pressures:

- ▶ The road-tyre friction.
- ▶ The cornering stiffness.
- ▶ The contact patch of the tyre with the road.

Careful management of tyre pressure can improve tyre life and improve tractive effort as well as assisting in maintaining the vehicle's braking and stability performance.

Ensuring optimal tyre pressures reduces the stopping distance that can be achieved without losing directional control.

A Central Tyre Inflation (CTI) system manages the air pressure in all the tyres in an axle group and use a compressor or high pressure air reservoir

and valve system to inflate or deflate the tyres to the selected pressure. The system issues alerts if the selected pressure levels cannot be met.

CTI systems allow the driver to vary tyre pressure to accommodate different loads and conditions. A CTI system can be retrofitted, but requires the axle hub and wheel assembly to be compatible with the air inflation system as part of the retrofit.

Tyre Pressure Monitoring Systems (TPMS) use pressure sensors located on the rim inside the tyre, to report the tyre pressure to a monitoring unit in the driver's cabin. An alert is issued if the pre-set pressure (usually set by the driver) is not met. TPMS sensors communicate via radio signals and are charged by wheel motion. TPMS can be easily retrofitted.

Also available on the market are commercial tyre management systems that monitor tyre and rim conditions, maintenance needs, and track wear rates to predict the life of the tyres.

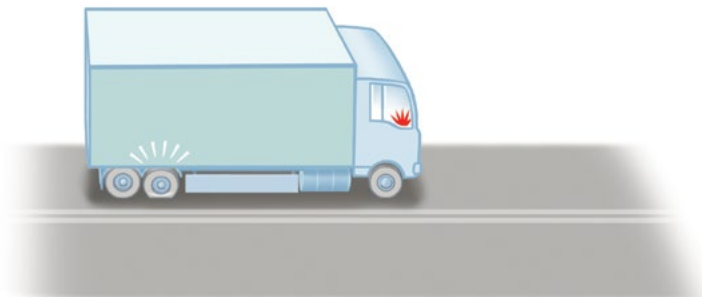

28 Tyre Puncture Prevention and Tyre Inflation

Innovative sealants are available that instantly seal tyre punctures caused by objects and prevent air loss even if the penetrating object becomes dislodged from the tyre. In most cases, by providing an instant tyre seal it avoids the need to stop at the side of the road, potentially in an unsafe location, to replace a deflated tyre.

The application of these sealants also helps to reduce slow air leaks which cause tyres to be under inflated, improving the tyre life as well as assisting in maintaining the vehicle's braking and stability performance. It is very important to check your tyres before you drive, and to always follow the manufacturer's recommendations for tyre maintenance.

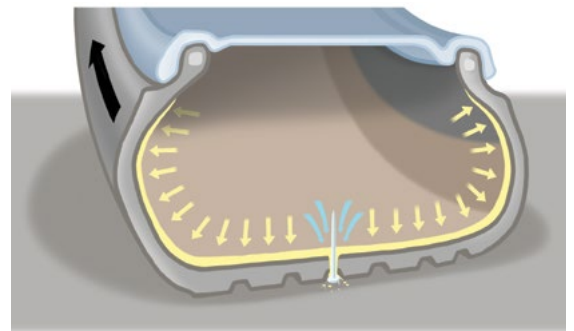

29 Connected Vehicle Technologies

Radio systems exist that can provide warning to drivers through a dedicated radio channel on potential hazards such as rail crossings or flooded causeways.

The Centre for Road Safety is currently incorporating a trial of connected level crossings at select locations within the Illawarra as part of the Cooperative Intelligent Transport Initiative (CITI).

These emerging technologies, called Cooperative Intelligent Transport Systems (C-ITS), use dedicated short range radio combined with cellular communication to enable vehicles to communicate with each other and with roadside infrastructure, such as traffic signals and railway level crossings. Drivers can be warned of potential hazards such as an imminent crash with another connected vehicle, roadworks, vehicles braking heavily ahead, the presence of emergency vehicles, broken down vehicles, red traffic lights ahead and trains approaching a railway crossing.

Proposed further applications include clearance height warnings, curve advisory speeds and the development of safer heavy vehicle platooning.



30 High Intensity Discharge (HID) Headlamps with Levelling System

HID or ('Xenon') headlamps have two distinct advantages over conventional halogen bulbs. Firstly, they are substantially brighter, and are fitted with projector lenses and therefore provide far stronger roadway illumination for heavy vehicles. Secondly, they do not use a filament bulb, so their failure rate is much lower. Because heavy vehicles can vary in height (depending upon loading level) it is recommended that HID headlamps are always installed with a levelling system so the driver can adjust the beam to avoid dazzling approaching drivers. Adaptive

headlamps that can help illuminate curved roads by swivelling up to five degrees in the direction of travel are also recommended (see technology 22). HID headlamps have three potential problems. They may cause glare to other road users and their blue light colour does not illuminate red and amber reflectors as well as the yellow-tinged light emitted by halogen bulb headlights. Additionally, the blue tinged white light does not penetrate fog as well as yellow or amber light. It is also important to ensure retrofitting kits meet Australian Design Rules and photometric performance requirements.

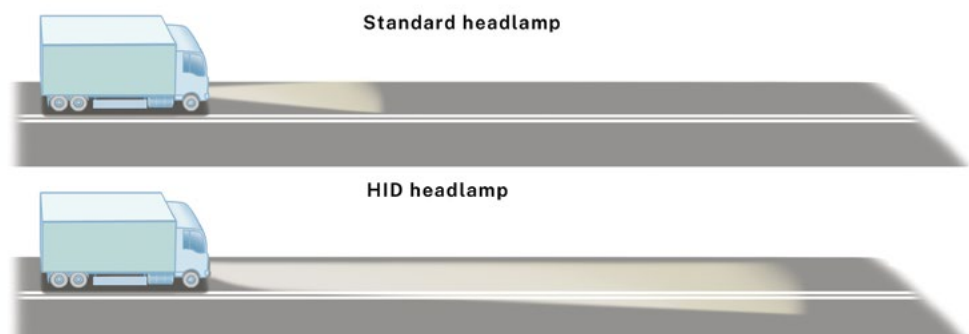

31 Automatic Traction Control (ATC) System

An ATC System complements an ABS (see technology 15) and prevents loss of traction which can result in rear-end slipping with a two-staged response. Firstly, the ATC reduces the drive torque. Secondly, it applies the service brakes on one or both sides of the drive wheels to prevent slip and to 'lock' the differential action. ATC is widely used on trucks that routinely encounter poor road conditions such as on logging and construction sites.

While ATC can avoid loss of directional control under tractive effort, many ATC systems are designed to work at low speeds only. In comparison, ESC systems (see technology 1) have an anti-slip function regardless of speed as a standard feature, including a response to events involving rear-end slipping due to loss of traction. For this reason, ESC systems have a greater safety benefit, however ATC systems are still a highly beneficial safety technology. ATC systems can be retrofitted in conjunction with ABS systems, but is usually more cost effective when purchased with a new vehicle.

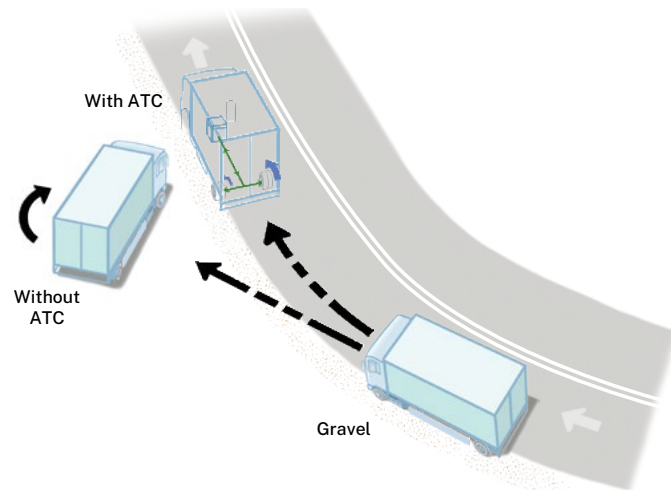

32 Reversing Safety Systems

The following three technologies can assist drivers to avoid crashes when reversing heavy vehicles and can be fitted to individual vehicles or combined:

1. Reversing Buzzer — provides a warning to other road users that the reverse gear has been selected. While reversing buzzers are common, particularly on delivery vehicles, they provide no feedback to the driver. They are seldom used on trailers because there is usually no reversing circuit.
2. Reversing Camera — provides the driver with a view of the space immediately behind the vehicle. These systems offer a high safety benefit for vehicles operating in areas of high pedestrian activity such as on passenger buses, in loading docks and for garbage trucks operating in narrow streets and pedestrian areas.

3. Reversing Sensor — uses an audible alarm to warn the driver that the vehicle is close to an object at the rear.

All of these systems can be retrofitted.

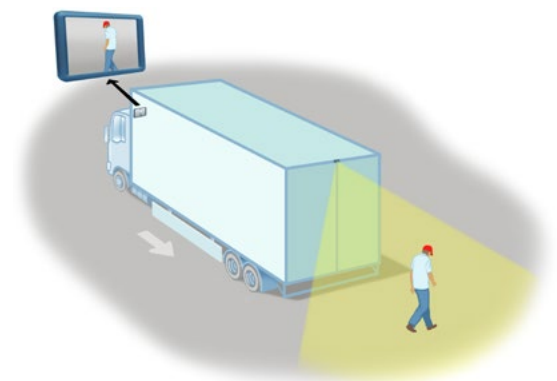

33 Spray Suppression Devices

Spray suppression devices are designed to reduce the amount of spray generated by the wheels when travelling on a wet road surface to provide better vision for the heavy vehicle driver, other road users devices including drivers of overtaking vehicles and protecting pedestrians and cyclists from overspray.

Spray suppression devices include mudguards and flaps, tight fitting wheel guards, 'Cats Whisker' spray suppression valances fitted to the sides of wheel guards, lips around the longitudinal edges of tight fitting wheel guards and 'energy absorbing' flaps that have a ribbed or pyramidal surface pattern. The aerodynamic design of some spray suppression devices can also deliver substantial fuel consumption savings. Spray suppression devices can be retrofitted.

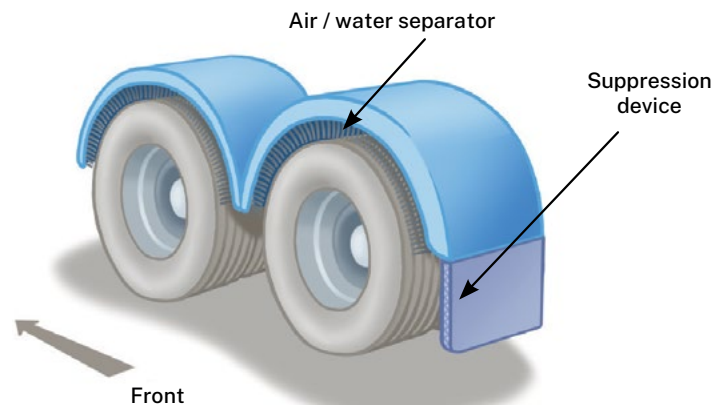

34 Roll Away Emergency Parking Brake System

A roll away emergency parking brake system automatically applies the heavy vehicle's parking brake when it detects the vehicle is moving while the ignition is off, the driver's seat has been vacated or the driver's door is open.

Some after-market engineering suppliers can separately provide spring-on emergency safety brakes that the driver can apply in the cabin in the event that a fault occurs with the truck service or park brakes. Roll away emergency parking brake systems can be retrofitted.



35 Alcohol Ignition Interlocks

Alcohol ignition interlock systems require the driver to provide a breath sample before operating a vehicle. The technology assesses the blood alcohol concentration (BAC) of the driver and will immobilise the vehicle if the driver exceeds the pre-set BAC limit. Systems available on the market are becoming increasingly more reliable and accurate. Alcohol interlocks for heavy vehicles are mostly supplied as an original equipment manufacturer option. Alcohol ignition interlocks can be retrofitted.



36 Acoustic Vehicle Alerting System (AVAS)

Some vehicles, such as electric and hybrid-electric vehicles, can be much quieter than those which have an internal combustion engine, particularly at low speeds. To help pedestrians, bicycle riders, children, and other vulnerable road users detect the presence of a quieter vehicle, manufacturers may fit an Acoustic

Vehicle Alerting System (AVAS). The system uses speakers when the vehicle is moving at slow speeds, both forwards and in reverse, to alert surrounding road users of its presence. The sound being emitted will alert other road users of the vehicle with changes relative to factors such as vehicle acceleration and speed.

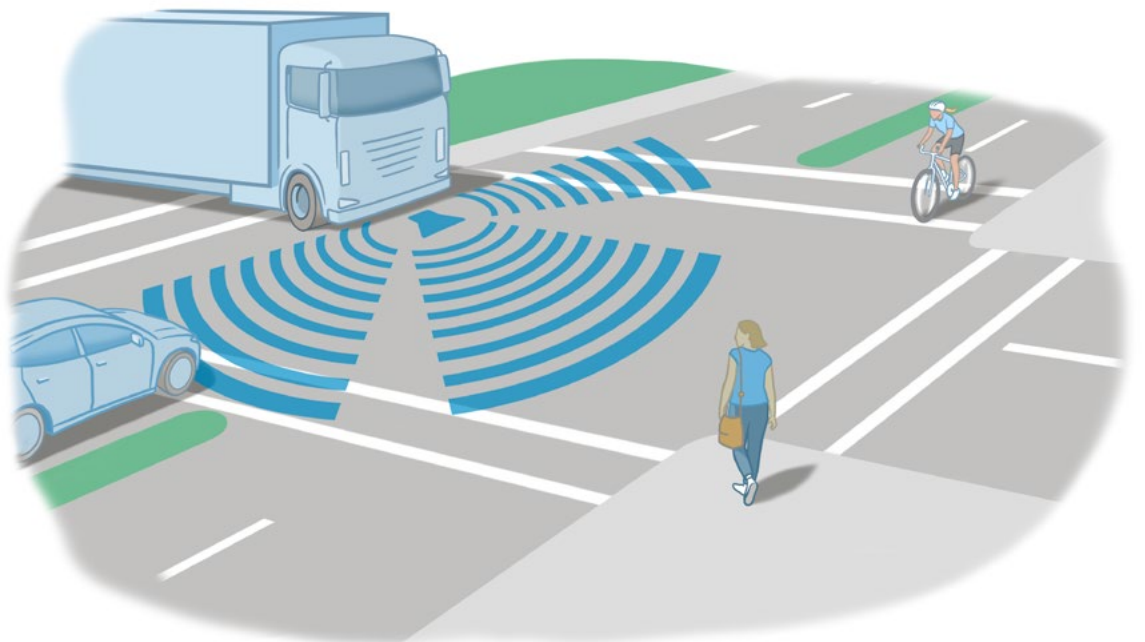

37 Motion Inhibit

Due to their weight and size, trucks can have bigger blind spots than other vehicles. Trucks have four main blind spots: at the front, rear and sides of the vehicle.

Heavy vehicle blind spots can pose a high risk for other road users - including motorcyclists, cyclists and pedestrians - especially in urban environments.

A motion inhibit feature will help address the blind spot immediately in front of the vehicle where vulnerable road users can be easily missed. The system will use sensors to pick up on the presence of another road user and will prevent the vehicle from moving forward from a stationary position.

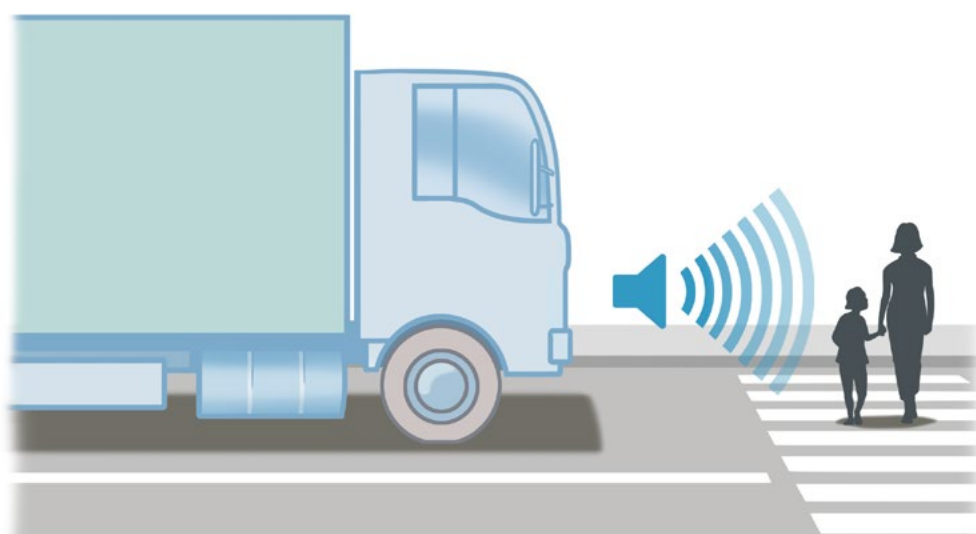

Protective Technologies

Protective systems features are safety technologies that assist to reduce the severity of a crash. They include the following technologies you should consider when purchasing your next heavy vehicle or making after-market improvements.

38 Suspension Seats with Integrated Seatbelts

A heavy vehicle driver will have a much better chance of surviving a serious crash when wearing a properly adjusted seatbelt. A driver suspension seat with an integrated seatbelt provides the most comfortable driving experience because the seatbelt anchors move with the seat to avoid seatbelt retraction and locking. Suspension seats also help reduce fatigue and back injuries, especially when operating in rough road conditions. Free-standing suspension seats can be retrofitted, however they need precise engineering to anchor them correctly.



Suspension seat with integrated 3 point seatbelt

39 Seatbelts for Buses

Lap sash seatbelts that are properly worn and adjusted provide the best form of protection for bus passengers in a crash. Seatbelts can be retrofitted, however installations in NSW require certification by an Approved Vehicle Examiner.

For buses, a double seat consisting of two adult seating position may be fitted with an additional centre seating position for children under 12, on the basis it complies with the relevant notices.



40 Rear Underrun Protective Devices (RUPDs)

RUPDs prevent lighter vehicles from running under the rear of a heavy vehicle and being damaged by the heavy vehicle's unyielding structure. Additionally, if the barrier has energy absorbing properties the crash deceleration forces could be significantly reduced and therefore the survival rates for the occupants of lighter vehicles are considerably improved. RUPDs can be retrofitted, however it is important the devices do not interfere with the heavy vehicle's functionality when installed.

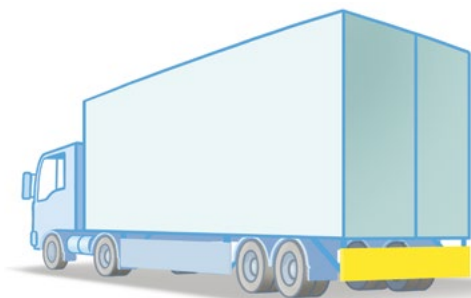

41 Side Underrun Protective Devices (SUPDs)

Side Underrun Protection Devices (SUPDs) reduce the likelihood of pedestrians, cyclists and motorcyclists from entering under the sides of a heavy vehicle and being run over by the rear wheels. SUPDs are designed mainly for low-force side crashes and can be retrofitted, however it is important the devices do not interfere with the heavy vehicle's functionality when installed.

A flat impacted tested panel that totally closes that side rail area is considered best practice. Compared to traditional side underrun rails, they further reduce the risk of pedestrians and cyclists being pulled under the wheels in a crash.

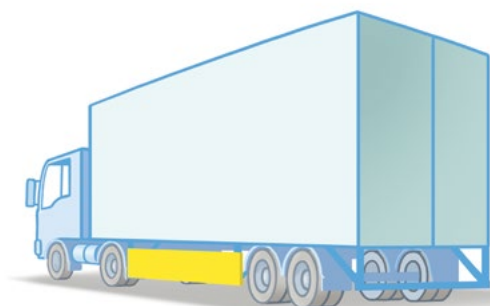

42 Front Underrun Protective Devices (FUPDs)

FUPDs act in two ways to minimise the severity of crashes with the front of a heavy vehicle. Firstly, they assist occupants of smaller vehicles to survive crashes with the front of a heavy vehicle by preventing the smaller vehicle from running under the heavy vehicle, and possibly deflecting it away. Secondly, they may protect the steering and front axle components of the heavy vehicle, which could assist the heavy vehicle driver to maintain control immediately after a crash. The safety benefits of FUPDs are increased if they have energy absorbing qualities. Some FUPDs are integrated with a bull bar in their design. FUPDs can be retrofitted, however it is important the devices do not interfere with the heavy vehicle's functionality when installed.

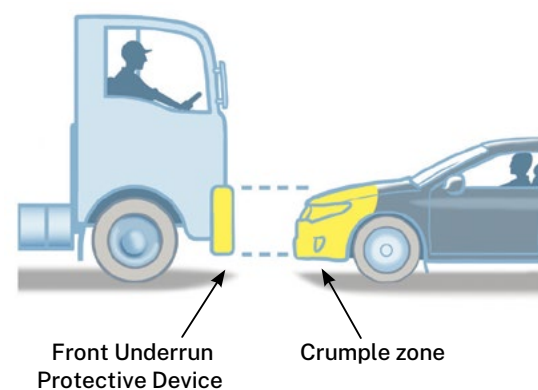

43 Supplementary Restraint System (SRS) Airbag

An SRS airbag protects vehicle occupants in the event of a severe crash. While SRS driver airbags are a standard feature on nearly all European heavy vehicles, this technology is not generally standard in Australian, North American and Japanese manufactured models. Significant safety benefits are gained when driver airbags are coupled with a suspension seat with an integrated seatbelt which can have a coordinated seatbelt locking mechanism (see technology 38). Driver SRS Airbag Systems cannot be cost effectively retrofitted to vehicles not originally equipped with them.



44 Rollover Side Curtain Airbag

The side curtain airbag activates instantaneously in the event of a rollover crash, deploying from the top of the door rails above the side window. The airbag forms a cushion between the driver or passenger and the window and stays inflated to provide enhanced protection in the event of a rollover crash.



45 Cabin Strength Standards

By intelligent design, heavy vehicle manufacturers can increase the strength of the cabin, along with the occupant's chance of survival in the event of a rollover or severe crash. To protect the occupants from serious injury, a well-designed cabin must not intrude into the defined space for occupant survivability.

Original features to look for when purchasing a new vehicle, which cannot be retrofitted, include: shaped panels (roof and floor pan) to increase bending strength without adding weight, strong structural panels, triangulation of structural members and gussets between intersecting structural members.

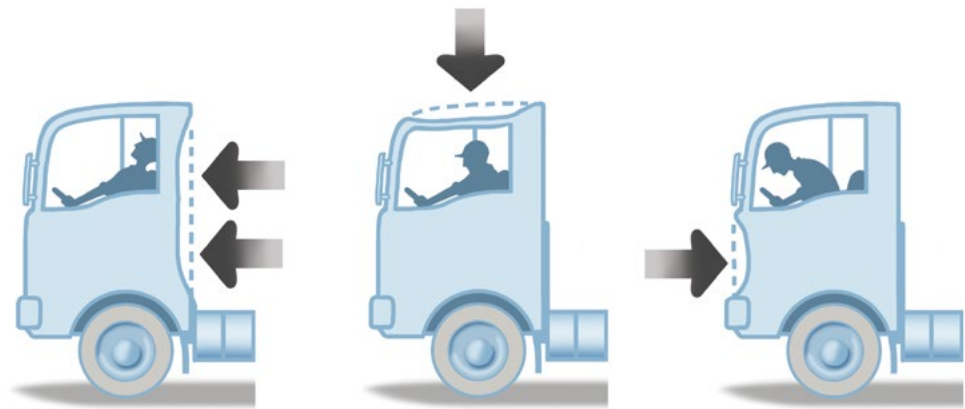

46 Seatbelt Wearing Monitors

Seatbelt wearing monitors provide an indication to drivers when the seatbelt is unbuckled. A seatbelt monitoring system may also be used to record seatbelt use in a post-driving report. Many European manufactured heavy vehicles have seatbelt monitors, but they are less common in Australian, North American and Japanese vehicles. Seatbelt monitoring systems can be retrofitted.



47 Automatic Brake Adjustment (ABA) Devices

An ABA device is an optional feature for drum brakes and a standard feature for disc brakes. A vehicle with poor brake adjustment may not meet legal stopping distance performance requirements. Poorly adjusted brakes will also affect brake wearing and can adversely impact on the performance of an ABS installation (see technology 15). ABA devices are readily available for retrofitting and quite cost effective as they can assist in reducing brake adjustment downtime.

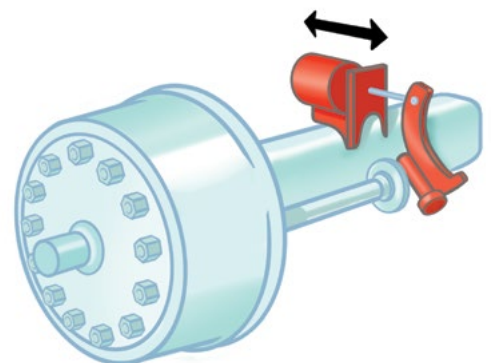

General Safety

General safety technologies provide workplace safety benefits. They include the following technologies you should consider when purchasing your next heavy vehicle or making after-market improvements.

48 Electricity Line Proximity Warning Devices

Vehicles with a metal component capable of lifting higher than six metres above the ground such as tip trucks, cranes and fire trucks with ladders may be at risk of contacting overhead power lines. Drivers may be insulated by their cabins, but anyone in contact with the vehicle can be electrocuted. Electricity Line Proximity Warning Devices sense the electric field surrounding a power line and sound an alert. These devices can be retrofitted as a stand-alone device with an independent power source.

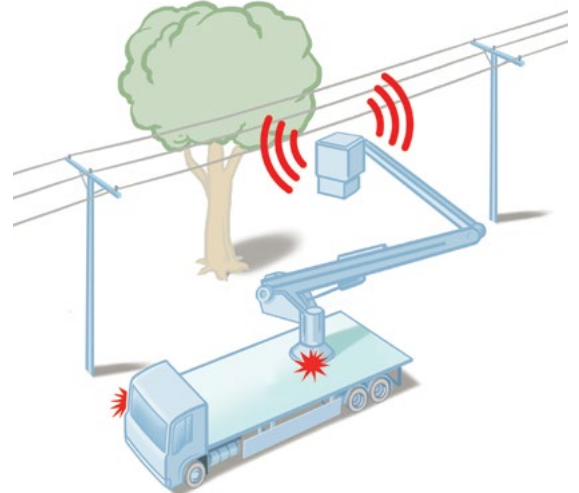

49 In-Cabin Noise Quality

Cabin noise level is a significant factor to consider when purchasing a vehicle. High cabin noise levels are likely to increase the driver's stress and reduce concentration, as well as inducing driver fatigue that increases the risks of road crashes and hearing loss in the long term. High cabin noise levels result from multiple factors including the cabin's proximity to the exhaust outlet, muffler, exhaust, transmission, cooling fans and turbochargers.

Treatments and the practicality of reducing in-cabin noise levels will depend on the source/s of the noise and existing cabin design, but a number of remedies include fitting:

- ▶ Noise absorbing close-cell foams and padding.
- ▶ Heavy barrier layers in mats and insulation.
- ▶ Effective isolation mounts, particularly for mufflers.
- ▶ Cooling fans with a low-noise design.

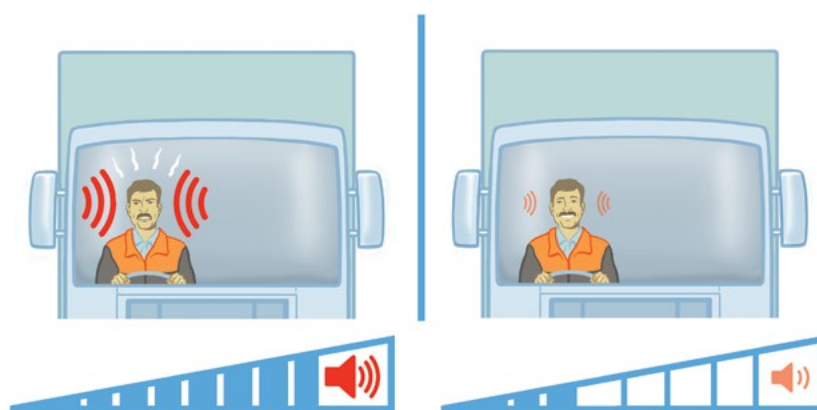

50 Driver Ride Quality

The most apparent aspect of ride quality is that a comfortable vehicle leads to a more enjoyable driving experience. Poor ride quality not only affects driver comfort, but can also cause driver fatigue and long-term health problems. Ride quality should be an important consideration when purchasing a new heavy vehicle.

Small vibrations that are unnoticed on short trips can easily lead to fatigue on longer trips. In extreme cases, poor ride quality has the added safety issue of poor vehicle handling, especially when a vehicle has wandering steering and can deviate without constant driver steering input. Most poor cabin ride quality results from the inadequate isolation of the driving seat from the road, which can be greatly improved by a good choice of suspension seats, cabin suspensions, and axle suspensions.

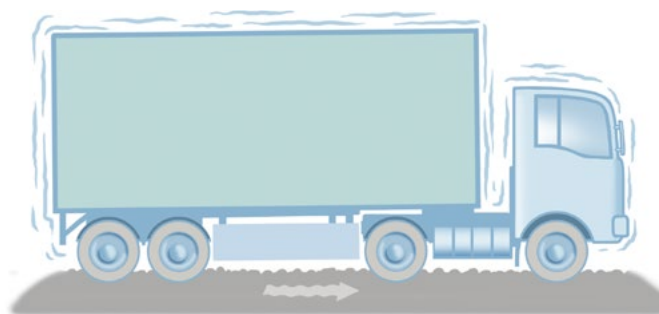

51 Ergonomic Cabin Design

An ergonomically designed cabin is crucial to driver comfort and has indirect road safety benefits through reducing driver fatigue. A detailed assessment of driving tasks and functions should consider the following inclusions and improvements in ergonomic cabin design:

- ▶ Safe entry and access to the cabin; including steps and grips.
- ▶ A seat that encourages good posture — preferably a suspension seat with an integrated seatbelt (see technology 38).
- ▶ Instruments which are easily visible and sensibly located so the most commonly used instruments are grouped together, glare free, and do not unnecessarily distract the driver.
- ▶ Switches and controls within easy reach, with those most commonly used at fingertip locations (no need to look away).
- ▶ Acceptable ride quality (see technology 50).
- ▶ Acceptable cabin noise level (see technology 49).
- ▶ Easily adjusted ventilation and climate controls.
- ▶ Comfortable pedal locations and angles.
- ▶ Wide visibility angles (see technologies 20 and 59).
- ▶ Easily adjusted mirror to enhance road vision and tinted mirrors for night use.



52 Tipper Safety Systems

There are a number of safety devices that can be fitted to vehicles that raise their body. These include:

- ▶ An inclinometer that continually monitors the angle of the vehicle in relation to the ground during the tipping process and assists in the prevention of overturns.
- ▶ A sensor to detect and warn the driver if the tailgate is open or closed, to minimise incorrect operation of the vehicle.
- ▶ A camera fitted to provide a view of the body from the driver's cabin, providing the driver with improved visibility.
- ▶ A hydraulic ram interlock system to prevent the raising of the body at speed, to minimise incorrect operation of the vehicle.
- ▶ An external voice warning sounder to provide warning to surrounding pedestrians.
- ▶ An in-cabin display unit fitted to provide an aid that the vehicle is operating correctly to the driver.

Monitor to provide assistance to the driver for rear body view
• internal voice warning system
• hydraulic ram interlock

A camera fitted to provide a view of the body

Sensor to detect if the tailgate is open or closed

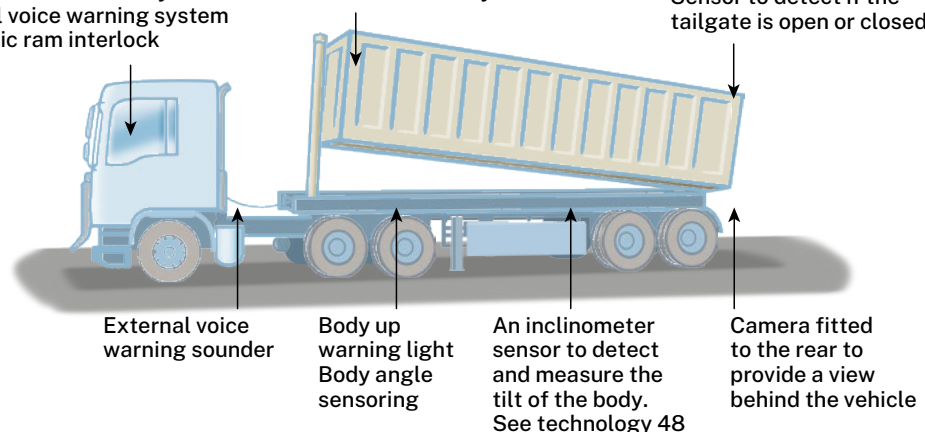

53 Tipping-Trailer Stability Protection System

Long rear-tipping trailer use is increasing in Australia. These trailers sometimes have to be raised to a tipping angle of greater than 45 degrees to completely unload. The longer the trailers are, the more vulnerable they are to toppling over in strong winds or if the rear axles are not on solid ground.

This is particularly true of tip-over axle semi-trailers because substantial weight is temporarily placed on one rear axle. Warning systems are available which sense the pressure in one air suspension bag on each side of the trailer. A warning is given if the pressures on each side of the trailer vary significantly when the lifting circuit is active. These systems may be part of integrated systems that provide safeguards to the operation of tipping trailers, such as a warning alert when the body is raised.

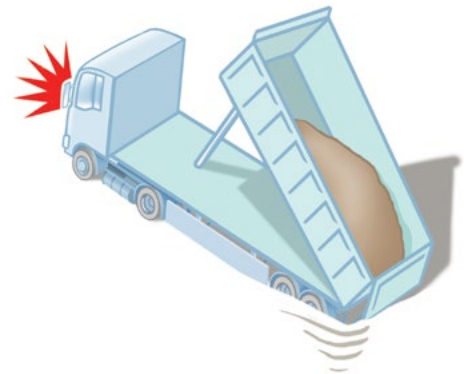
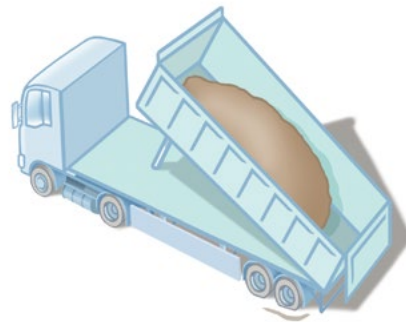

54 Intelligent Speed Adaptation (ISA) Warning System

An ISA system warns the driver when their vehicle exceeds the speed limit. This can be achieved by the vehicle's advanced cameras which recognise speed limit signs, or by the combination of an on-board speed zone database and GPS, whereby the vehicle knows the applicable speed limit based on the vehicle's location. Some ISA systems combine both of these technologies.

ISA systems can be retrofitted and some are currently included by original equipment manufacturers. Some ISA systems are also available as an app for smartphones.



55 Fire Suppression Systems

The majority of heavy vehicle fires start in the engine compartment. Most heavy vehicles carry a fire extinguisher but they are often inadequate for suppressing an engine compartment fire.

Fire suppression systems are commercially available that spray fire retardant chemicals or water for one to two minutes into the vehicle's engine compartment, after being automatically triggered by sensor/s sensing excessive temperatures, or by a manual switch at the driving position. Fire suppression systems need to be installed by a specialist equipment supplier who can determine the size and the suppression chemicals required for a particular vehicle.

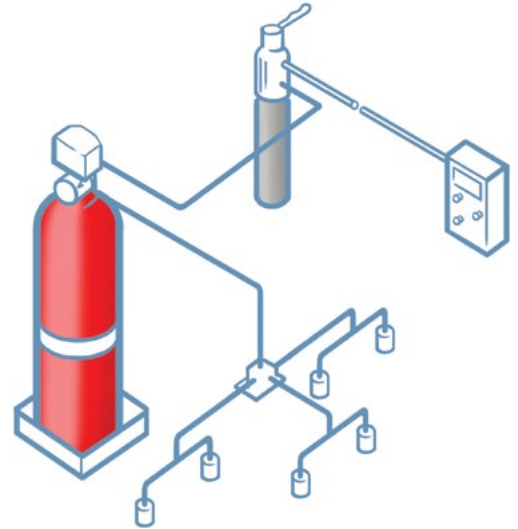

56 Automatic Crash Notification (ACN) System

The intelligent transport control systems available for heavy vehicles are becoming increasingly sophisticated. Heavy vehicles can now be monitored and drivers directed remotely in real-time. An Automatic Incident Reporting System notes, records and reports dangerous incidents – similar to a 'black box' recorder on an aeroplane. Incidents might be identified by severe decelerations or deployment of safety systems such as ESC or an SRS airbag (see technologies 1 and 43).

Once the vehicle's system is activated by an incident, it sends telemetric messages to a remote monitoring centre. A good system can advise the location, nature of the crash and identify the driver to facilitate a timely and appropriate emergency response. Some vehicle telemetrics can also help drivers to plan their routes, avoid traffic problems, receive and send business information, manage their statutory driving hour requirements, report mass loading, vehicle problems and location. These systems can be retrofitted.

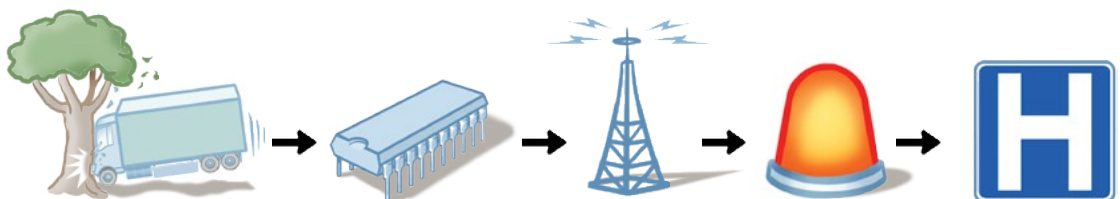

57 Wheel Temperature Monitoring

Wheel temperature monitors for heavy vehicles are available in the form of inexpensive thermal labels which are easily fixed to the wheels. The thermal labels permanently change colour to indicate that the vehicle's wheels have overheated and exceeded temperatures of 120 degrees Celsius.

Excessive wheel temperatures indicate possible poor bearing condition and/or lubrication, brake failure, dragging brakes or poor brake balance which could result in a fire if the temperature of the wheel or tyre components reaches ignition point. Thermal labels can be retrofitted.

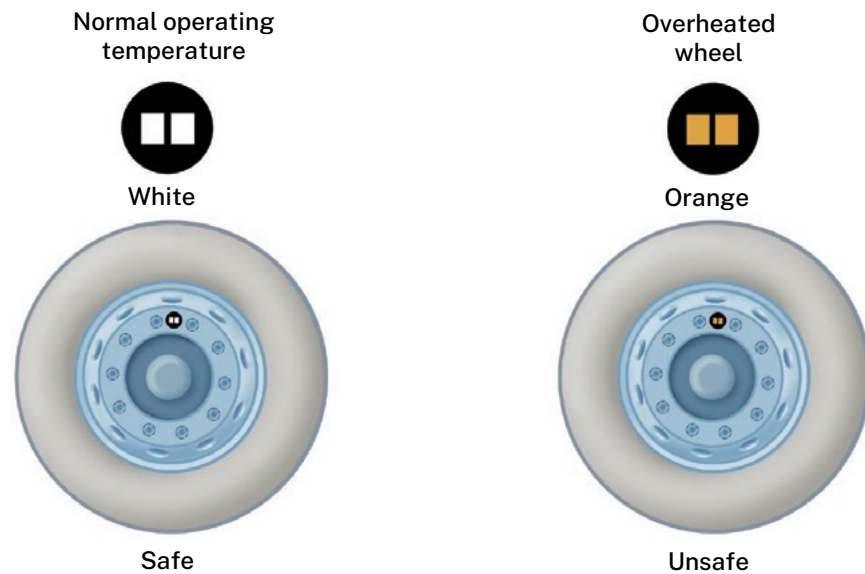

58 Field of View

By intelligent design, heavy vehicle manufacturers can increase the driver's visibility, as well as lowering the risk of a crash. A detailed assessment of the driver's field of view should consider the following design:

- ▶ The cross-section width of the A-pillar, as the geometry of the A-pillar has a substantial effect on the size and position of obscured regions.
- ▶ The bonnet profile of the vehicle.
- ▶ The gap between the mirror and the A-pillar.
- ▶ The thickness of the mirror housing.
- ▶ The size of the side windows.
- ▶ Cabin height (particularly for urban environments and applications where the driver regularly leave the cabin)
- ▶ Additional windows fitted to doors.
- ▶ See technology 59 and 60 Fresnel lens and mirrors that increases the driver's vision adjacent to the vehicle.

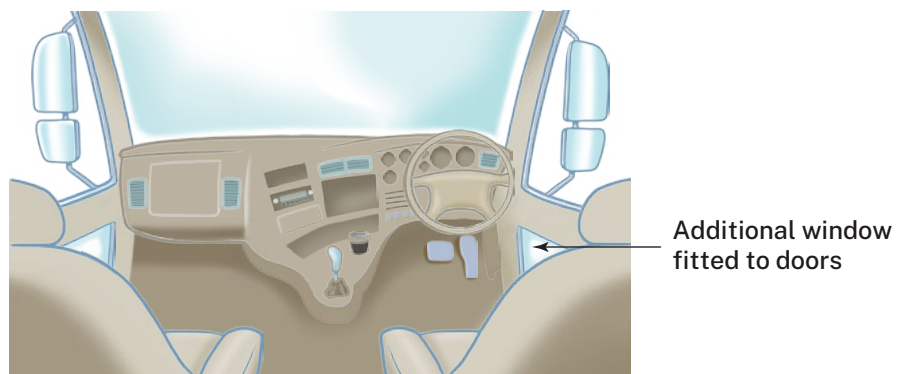

59 Fresnel Lens

A Fresnel lens is a thin plastic lens that adheres to the passenger door window. The driver can see through the concentric ring surface with its optical properties providing a wide angle view. At a glance the driver can see any vulnerable road user that might be hidden in blind spots alongside the passenger door.

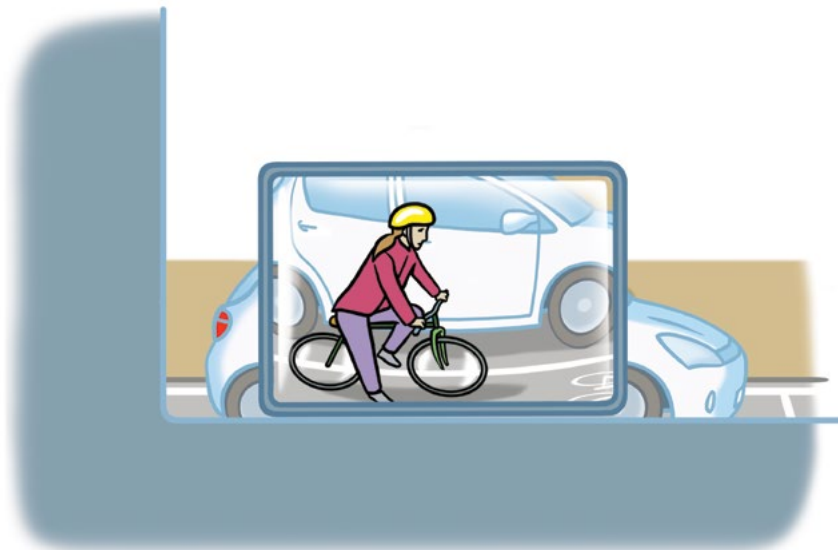
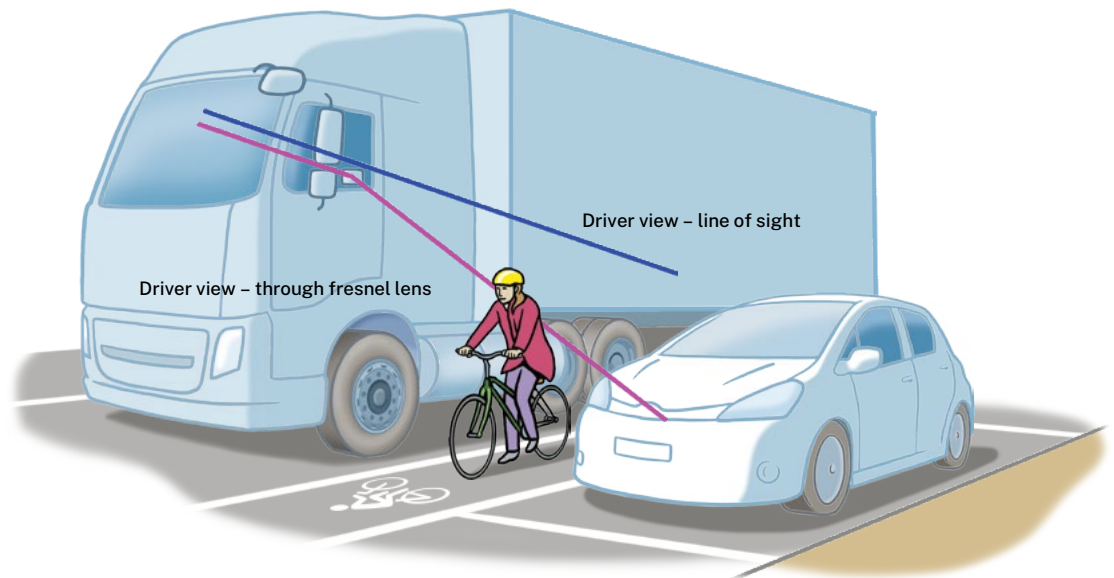

60 Mirrors

Mirrors fitted to vehicles improve the driver's indirect field of view.

Mirrors improve the safety of vulnerable road users including pedestrians, cyclists and motorcyclists.

These groups are at a high risk of being involved in a crash with heavy vehicles because of blind spots in the immediate areas around the vehicle.

The illustration provides the field of view area for different classes of mirrors.

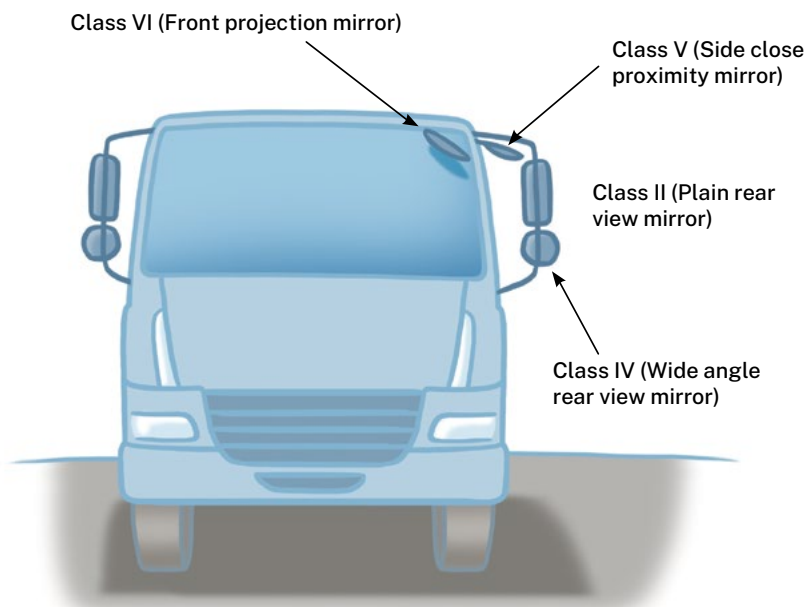
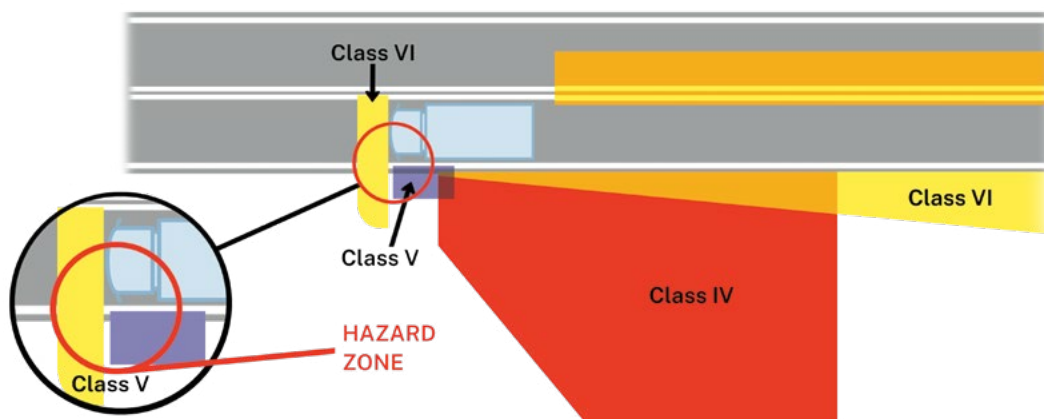

61 Onboard Weighing System

Onboard vehicle weighing systems assist the driver to operate the vehicle safely, as they let the driver know exactly how much mass is being carried by each axle.

Overloaded heavy vehicles have significantly impaired braking and cornering capabilities, and are more likely to experience premature vehicle component failures.

Knowing how much mass is being carried by each axle, assists with correct load placement and in the event of a load shift, provides an alert to the driver to adjust the load.

Transporting correct payloads reduces maintenance expenses on transmission systems, suspensions systems, brakes and tyres and increases the operating lifetime of the vehicle. Onboard weighing systems also provide drivers the assurance of transporting loads to the full legal limits.

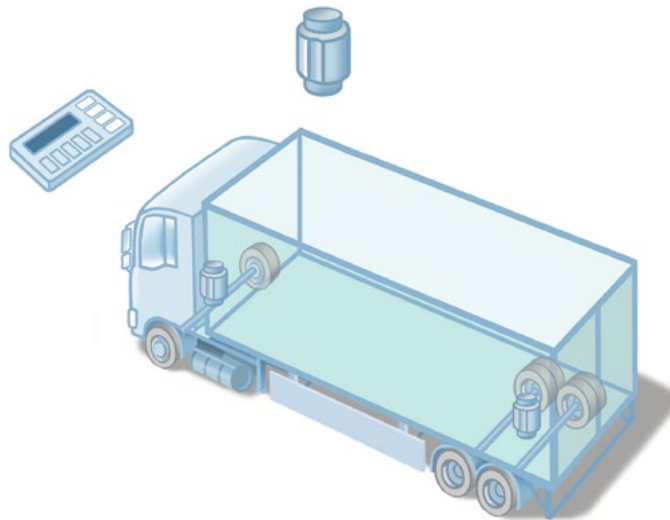

62 Emergency Hatch

An emergency roof hatch can be used in the case of an emergency, such as a rollover crash where the cabin doors have become inoperable or blocked.

Emergency hatch

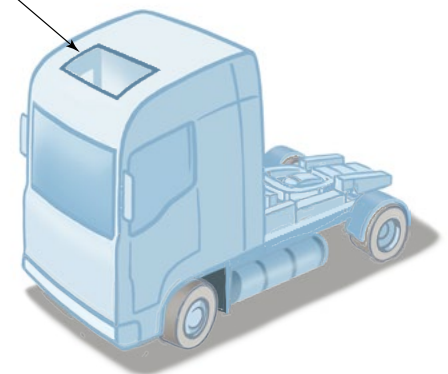



© Transport for New South Wales

Users are welcome to copy, reproduce and distribute the information contained in this report for non-commercial purposes only, provided acknowledgement is given to Transport for NSW as the source.

March 2024
Stock code 45094061
ISBN 978-1-922338-76-1

