



Technical Note – TN 005: 2019

Issue date: 20 November 2019

Effective date: 20 November 2019

Subject: Updates to ESC 215 *Transit Space*, version 4.9

This technical note is issued by the Asset Standards Authority (ASA) to notify amendments to ESC 215 *Transit Space*, version 4.9.

It replaces the following technical notes:

- TN 026: 2018 *Update to ESC 215 Transit Space, version 4.9 to introduce Sub-Medium rolling stock*
- TN 089: 2015 *Update to Medium Electric rolling stock outline diagram in T HR RS 00100 ST (RSU 110) and ESC 215*

In addition, this technical note includes amendments to the requirements of Extended Medium, Wide Electric, Out of Gauge Load, NZZA Wagon and ANZR outlines.

TN 026: 2018 and TN 089: 2015 will be withdrawn with the publication of TN 005: 2019.

1. Introduction of Sub-Medium rolling stock

A new rolling stock outline, to be known as Sub-Medium, will be introduced to the electrified portion of the TfNSW Metropolitan Heavy Rail Network. The Sub-Medium will comply with the Medium Electric rolling stock outline, but have what is termed a two-stage kinematic response. Operating on normal track conditions, Sub-Medium vehicles will be specified to comply with the general kinematic tolerances in Section 10.2 of ESC 215. Under certain prescribed track conditions and speed, these vehicles will be specified to generate a reduced kinematic response.

Prior to the deployment of Sub-Medium rolling stock on certain sections of the network, the track width classification of those sections will be altered from Narrow to Sub-Medium or from Narrow to Medium. For design, construction and subsequent maintenance purposes, transit space requirements change with the publication of this technical note. It includes the following details:

- the Sub-Medium rolling stock outline for use by infrastructure designers
- reduced vehicle kinematic tolerances for Sub-Medium rolling stock operating on Prescribed Condition track for use by infrastructure designers
- reduced track kinematic tolerances for Prescribed Condition track locations
- locations where Sub-Medium rolling stock are planned to operate
- additional locations where Medium Electric rolling stock are planned to operate

At all track locations other than the Prescribed Condition track locations, Sub-Medium rolling stock will be permitted to respond to track geometry and conditions in the same manner as all other passenger rolling stock.

As Prescribed Condition track will be traversed by a variety of rolling stock, the same reduced track parameters may be applied regardless of the rolling stock being assessed.

Within Prescribed Condition track locations, adoption of track kinematic parameters that are tighter than the reduced parameters for the two-stage kinematic response will not be permitted.

For the purposes of track and infrastructure design, the Sub-Medium rolling stock outline is identical to the Medium Electric outline in all respects, except its kinematic response under certain track and speed conditions. These vehicles are authorised to operate wherever Medium Electric are currently authorised. On Prescribed Condition track, only Sub-Medium rolling stock are specified to provide a reduced kinematic response, thus they are planned to operate on the track slab section between Edgecombe and Zig Zag.

To allow track and infrastructure changes to be implemented to allow Sub-Medium and Medium Electric rolling stock to operate beyond Springwood, the transit space requirements in that area require amendment as indicated in **Attachment 1 – Updated matrix A, of this technical note**. In this context, **replace all rows for 10177 Main West, Down and 10178 Main West, Up as shown in that section**.

1.1. Section 10 Authorised rolling stock outlines

Add the following towards the end of Table 13:

Rolling stock outline name	Base outline	Pantograph included	Reference drawing
Sub-Medium	Medium	Yes	Figure 15

1.2. Section 10.2 General kinematic tolerances

Add the following towards the end of Table 14:

Sub-Medium rolling stock outline on Prescribed Condition track			
Lateral	Relative to the plane of the superelevation (with any superelevation variation applied)	Body to wheelset <i>(Note: Wheel wear and wheel/rail free play is accounted for in the Lateral extra clearance – they do not need to be factored in.)</i>	± 50 mm total
	Radial (parallel to the displaced outline)	Extra clearance	+ 100 mm
Vertical	Relative to the displaced vehicle centreline	Bounce upwards	+ 40 mm
		Bounce downwards	0 mm
	Radial (parallel to the displaced outline)	Extra clearance upwards	+ 100 mm
		Extra clearance downwards	0 mm
Rotational	Roll about the displaced roll centre of the rolling stock outline	<i>Note: The roll centre moves laterally and vertically with the rolling stock outline.</i>	± 1.3°

1.3. Section 11.3 Prescribed Condition track

Add the following new section after Section 11.2:

Only track which is designed and maintained to a specific set of limits and tolerances can be considered as Prescribed Condition track. For design limits, including speed, refer to TN 025: 2018 in ESC 210. For maintenance condition reporting levels, refer to TMC 203.

This section details the tolerances to be included to allow for the variation of track from its design when calculating the Kinematic Structure Gauge.

Track tolerances used in the calculation of the Kinematic Structure Gauge may differ from those imposed for design or maintenance of track. They represent average figures. They shall not be used for purposes other than stated here. The track tolerances detailed in Table 15a are absolute limits and can be used for all authorised rolling stock outlines, when calculating the Kinematic Structure Gauge on Prescribed Condition track:

Table 15a – Track tolerances for Prescribed Condition track

Prescribed Condition track locations			
Direction	Description	Relative to	Tolerance
Lateral	Rail variation	Rail wear	10 mm
	Alignment	Horizontal difference from design	± 10 mm
Vertical	Level	Difference from design	± 20 mm
Rotational	Superelevation	Difference from design	± 10 mm

2. Removal of ANZR outline

ANZR outline has previously been removed.

Delete all references to ‘ANZR’ outline in Table 16 of Section 13.3.2.1.

3. Amendments to Extended Medium, Wide Electric, Out of Gauge Load and NZZA Wagon outline requirements

Extended Medium and Wide Electric outlines have been phased out and will be operating in limited numbers only. These outlines are no longer required to be considered while determining track centres and clearance points.

The Out of Gauge Load and NZZA Wagon outlines are no longer permitted to operate on the TfNSW Metropolitan Heavy Rail Network. These outlines are no longer required to be considered when designing or maintaining any infrastructure.

3.1. Appendix A - Authorised rolling stock outlines

The following changes are made to the 'Authorised rolling stock outlines on track sections' table, as shown in sample Attachment 1 – Updated matrix A:

- **Amend Legend to reflect new definition of 'R' as follows:**

R	The outline is authorised in limited numbers only. It does not need to be considered when designing or maintaining track centres and clearance points but it shall be considered when designing or maintaining other infrastructure including platforms.
---	--

- **Amend Legend to reflect the new definition of 'S' as follows:**

S	The outline is authorised but has restricted operating conditions through platforms. It does not need to be considered when designing or maintaining track centres, clearance points and platforms, but it shall be considered when designing or maintaining all other infrastructure.
---	--

- **For Extended Medium outline column, across all base codes, replace all references to 'Y' with 'R'** (a sample is given as Attachment 1 – Updated matrix A).
- **For Wide Electric outline column, across all base codes, replace all references to 'R' with 'S'** (a sample is given as Attachment 1 – Updated matrix A).
- **For Out of Gauge Load outline and NZZA Wagon outline columns, across all base codes, replace all references to 'S' with 'N'** (a sample is given as Attachment 1 – Updated matrix A).

Note: These changes apply to the entirety of Appendix A.

Attachment 1 – Updated matrix A

Authorised rolling stock outlines on track sections

Authorised rolling stock outlines on track sections																				
Legend																				
Y	The outline is authorised to operate, and shall be considered when designing or maintaining the infrastructure						S	The outline is authorised but has restricted operating conditions through platforms. It does not need to be considered when designing or maintaining track centres, clearance points and platforms, but it shall be considered when designing or maintaining all other infrastructure.												
P	The outline is not currently authorised, but it is planned to be authorised, and shall be considered when designing or maintaining the infrastructure.						T	The outline is authorised under restricted operating conditions. It does not need to be considered when designing or maintaining any infrastructure or track centres.												
R	The outline is authorised in limited numbers only. It does not need to be considered when designing or maintaining track centres and clearance points but it shall be considered when designing or maintaining other infrastructure including platforms.						N	The outline is not authorised and does not need to be considered when designing or maintaining the infrastructure.												
		From			To			Rolling stock outlines												
Base code	Track name	km	Track location	Location description	km	Track location	Location description	Narrow Non-Electric	Narrow Square	Narrow Container	Intersystem	Narrow Hopper	Double Stack	Narrow Electric	Medium Electric	Extended Medium	Wide Electric	Out of Gauge Load	NZZA Wagon	Sub-Medium
10177	Main West, Down	21.550	Granville	710 Points	58.828	Emu Plains	Signal 36.5	Y	Y	Y	N	Y	N	Y	Y	R	S	N	N	Y
10177	Main West, Down	58.828	Emu Plains	Signal 36.5	80.484	Springwood	118B Points	Y	Y	Y	N	Y	N	Y	Y	N	N	N	N	Y
10177	Main West, Down	80.484	Springwood	118B Points	145.430	Edgecombe	Start of track slab	Y	Y	Y	N	Y	N	Y	P	N	N	N	N	P
10177	Main West, Down	145.430	Edgecombe	Start of track slab	150.550	Zig Zag	End of track slab	Y	Y	Y	N	Y	N	Y	N	N	N	N	N	P
10177	Main West, Down	150.550	Zig Zag	End of track slab	156.361	Lithgow	Signal 97.1	Y	Y	Y	N	Y	N	Y	P	N	N	N	N	P
10177	Main West, Down	156.361	Lithgow	Signal 97.1	158.800	Bowenfels	CRN boundary	Y	Y	Y	N	Y	N	N	N	N	N	N	N	N
10178	Main West, Up	21.470	Granville	709 Points	58.828	Emu Plains	Signal 36.5	Y	Y	Y	N	Y	N	Y	Y	R	S	N	N	Y
10178	Main West, Up	58.828	Emu Plains	Signal 36.5	80.484	Springwood	118A Points	Y	Y	Y	N	Y	N	Y	Y	N	N	N	N	Y

Attachment 1 – Updated matrix A

Authorised rolling stock outlines on track sections																				
Legend																				
Y	The outline is authorised to operate, and shall be considered when designing or maintaining the infrastructure						S	The outline is authorised but has restricted operating conditions through platforms. It does not need to be considered when designing or maintaining track centres, clearance points and platforms, but it shall be considered when designing or maintaining all other infrastructure.												
P	The outline is not currently authorised, but it is planned to be authorised, and shall be considered when designing or maintaining the infrastructure.						T	The outline is authorised under restricted operating conditions. It does not need to be considered when designing or maintaining any infrastructure or track centres.												
R	The outline is authorised in limited numbers only. It does not need to be considered when designing or maintaining track centres and clearance points but it shall be considered when designing or maintaining other infrastructure including platforms.						N	The outline is not authorised and does not need to be considered when designing or maintaining the infrastructure.												
		From			To			Rolling stock outlines												
Base code	Track name	km	Track location	Location description	km	Track location	Location description	Narrow Non-Electric	Narrow Square	Narrow Container	Intersystem	Narrow Hopper	Double Stack	Narrow Electric	Medium Electric	Extended Medium	Wide Electric	Out of Gauge Load	NZZA Wagon	Sub-Medium
10178	Main West, Up	80.484	Springwood	118A Points	145.430	Edgecombe	Start of track slab	Y	Y	Y	N	Y	N	Y	P	N	N	N	N	P
10178	Main West, Up	145.430	Edgecombe	Start of track slab	150.550	Zig Zag	End of track slab	Y	Y	Y	N	Y	N	Y	N	N	N	N	N	P
10178	Main West, Up	150.550	Zig Zag	End of track slab	156.361	Lithgow	Signal 97.1	Y	Y	Y	N	Y	N	Y	P	N	N	N	N	P
10178	Main West, Up	156.361	Lithgow	Signal 97.1	158.800	Bowenfels	CRN boundary	Y	Y	Y	N	Y	N	N	N	N	N	N	N	N

4. Appendix B Rolling stock cross-sections

The Medium Electric rolling stock outline as shown in Figure 15 in Appendix B is amended to show that the roof line encompasses the Extended Medium Electric rolling stock outline. This amendment aligns with T HR RS 00100 ST *RSU 100 Series – Minimum Operating Standards for Rolling Stock – General Interface Requirements*.

Replace Figure 15 in Appendix B with the following:

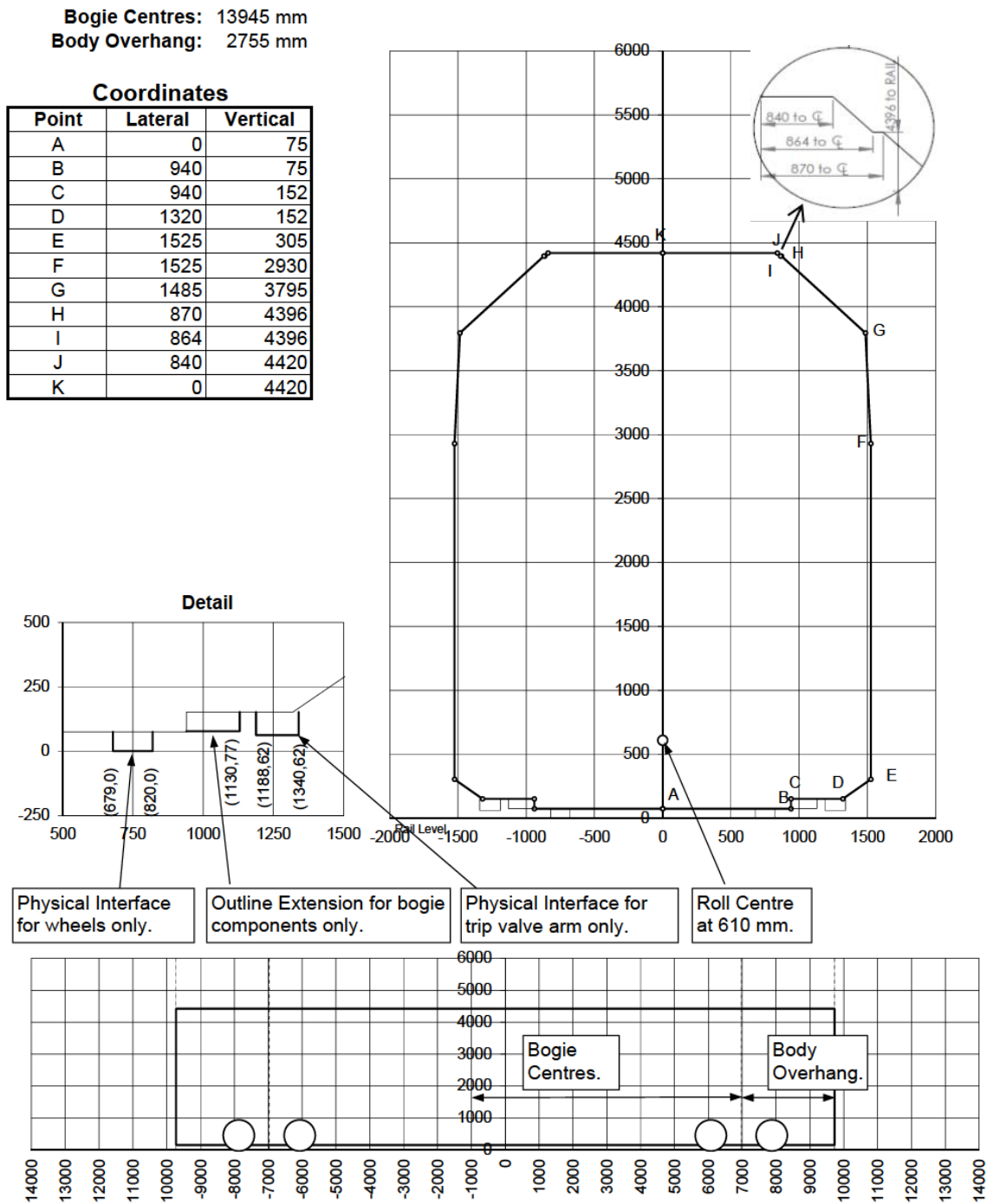

Figure 15 - Medium Electric rolling stock outline dimensions

Add the following dot points after Figure 15:

- all cross-section dimensions are symmetrical about the vehicle centreline
- the origin for all horizontal coordinates is the vehicle centreline
- the origin for all cross-section vertical coordinates is the rail level
- the origin for all pantograph vertical coordinates is the contact position with fully worn contact brushes
- all dimensions are in millimetres

Authorisation:

	Technical content prepared by	Endorsed by	Checked and approved by	Interdisciplinary coordination checked by	Authorised for release
Signature					
Date					
Name	Navneet Kaur	Michael Uhlig	John Paff	Peter McGregor	Andrea Parker
Position	Senior Track Engineer	Lead Rolling Stock Engineer	Lead Track Engineer	A/Chief Engineer	A/Executive Director

ESC 215

TRANSIT SPACE

Version 4.9

Issued April 2013

Reconfirmed 03 July 2019

Owner: Chief Engineer, Track

Approved by: Andrew Wilson
Technical Specialist
Wheel/Rail

Authorised by: Malcolm Kerr
Chief Engineer
Track

Disclaimer

This document was prepared for use on the RailCorp Network only.

RailCorp makes no warranties, express or implied, that compliance with the contents of this document shall be sufficient to ensure safe systems or work or operation. It is the document user's sole responsibility to ensure that the copy of the document it is viewing is the current version of the document as in use by RailCorp.

RailCorp accepts no liability whatsoever in relation to the use of this document by any party, and RailCorp excludes any liability which arises in any manner by the use of this document.

Copyright

The information in this document is protected by Copyright and no part of this document may be reproduced, altered, stored or transmitted by any person without the prior consent of RailCorp.

Document control

Version	Date	Summary of change
1	October 2006	First issue as a RailCorp document. Includes content from C 2101, C 2102, C 2103, C 2104, C 2105, C 2106, C 2108, C 2111.
2	April 2007	Minor corrections and additions; inclusion of requirements for transit space at platforms; definition of Infrastructure Manager; provision of service requirements for track centres.
3	October 2007	Clarification of clearance requirements for access roads; inclusion of clearance requirements below rail level for maintenance machines; correction of acceptance limits at platforms; clarification of measurement conventions for platform clearances
4	May 2008	Section 4 - Addition of consideration of aerodynamics in tunnels, and addition of text to reflect changes in Section 9 and 10; Section 9 - Inclusion of Tunnel walkway transit space requirements; Section 10 – Inclusion of new section on "Operating Safety Requirements covering clearance space for train crew; Section 16.1 – Inclusion of construction tolerances at structures (other than platforms); Table 18 – Change to allowable rolling stock outline in Dapto – Kiama section.
4.1	December 2008	Section 10 – Clarification of vertical extent of additional clearance at platforms; Section 14.3.2.4 - Change to incorrect reference; Appendix 1 – Addition of Airport Line to table of Authorised Outlines.
4.2	May 2009	Format change; Section 9 - Operating Safety Requirements - Reduction of minimum lateral clearance to existing infrastructure near platforms from 450mm to 350mm; Appendix 1 - Table 18 – Addition of Olympic Loop and Epping Chatswood to Table of Authorised rolling stock outlines
4.3	December 2009	Changes to reflect title and organisation changes; Section 7 - Redraw Fig 1 Normal Structure Gauge 1994 to reflect Flangeway depth of 38mm, include references to approved infringements, and include representation of rollingstock outline, kinematic envelope and clearance. New Fig 2 to show detail at rail level; Section 8 - Add dwarf signals, through girder underbridges and platform awnings to approved infringements; Section 13.3.2.4 – Removal of simplified formulae for calculation of clearances to platforms in transitioned track – replacement with requirement to use 3D modelling.
4.4	July 2010	New Section 3.3 Passenger platforms – includes mandating Level Access design. Sections 3.4 and 3.5 renumbered; Sections 13.3.2.4 and 13.3.2.5 – Changes to clarify 3D modelling and to revert to use of simplified formulae in some situations
4.5	February 2011	New Section 3.3 – Transit Space requirements in in stabling yards and sidings. Sections 3.4, 3.5 and 3.6 renumbered
4.6	August 2011	Section 3.7 - New section - Clearances for vegetation Section 10 - Changed use of Wide Electric, NZZA and Out-of-Gauge rolling stock outlines to desirable rather than mandatory. (Includes provisions of Engineering Waiver EWT 10/241). Section 12.2 - Deletion of contradictory statement regarding calculation of centre/end throw

Version	Date	Summary of change
4.7	October 2011	Appendix A - Note 1 added to Table 18 clarifying outlines suitable for Lidcombe Meeks Rd Goods.
4.8	April 2012	Reformatted to new template; 10.2 - Reduction of extra lateral clearance for determination of track centre clearances (includes content of EWT 11/302).; 11.1 - Table 15 – addition of term “Rail Variation” to differentiate rail wear from alignment tolerances; adjusted vertical tolerances from $\pm 150\text{mm}$ to $+100\text{mm} - 150\text{mm}$; Appendix A - Table updated to include Cronulla line, correct terminating points and allowable outlines
4.9	April 2013	See Summary table below

Summary of changes from previous version

Summary of change	Section
Control changes	Document control
Addition of requirement for approved electrical design for reduced overhead clearances	7.1.1.1
Inclusion of permanent and temporary speed signs as approved infringements Inclusion of equipment attached to tunnel walls as approved infringements Includes content from Engineering Waivers EWT 12/318 and EWT 12/330	8
Correction of error in formulae	13.3.1.2
Updated for operation of Narrow Square Outline	Appendix A

Contents

1	Purpose, Scope and Application	6
2	References	6
2.1	Australian and International Standards	6
2.2	RailCorp Documents	6
2.3	Other References	6
2.4	Definitions	6
3	Design Requirements	7
3.1	Structure Gauge	7
3.2	Infrastructure Service Requirements	8
3.3	Transit Space Requirements in Stabling Yards and Sidings	8
3.4	Passenger Platforms	8
3.5	Design Physical Interfaces	8
3.6	Operating Safety Requirements	9
3.7	Clearances for Vegetation	9
4	New Multi-Track Construction	9
5	Application	9
5.1	Normal Structure Gauge 1994 (Including Normal Track Centres)	9
5.2	General Kinematic Structure Gauge	10
5.3	Transit Space Waivers	10
6	Minimum Infrastructure Service Requirements	10
6.1	Horizontal	10
6.2	Vertical	12
6.3	Track Centres	13
7	Structure Gauges	13
7.1	Normal Structure Gauge 1994	13
7.2	General Kinematic Structure Gauge	17
7.3	Platform Kinematic Structure Gauge	17
7.4	Transit Space Waivers	18
8	Physical Interface Requirements	19
9	Operating Safety Requirements	21
10	Authorised Rolling Stock Outlines	21
10.1	Dynamic Rolling Stock Allowances	22
10.2	General Kinematic Tolerances	22
11	Track Tolerances	24
11.1	Open track	24
11.2	Platforms	25
12	Method of Calculation of Kinematic Structure Gauges	25
12.1	General	25
12.2	Calculation of Kinematic Envelope	26
12.3	Kinematic Track Centres	27
13	Calculation of Platform Kinematic Structure Gauge	27
13.1	General	27

13.2	Platform Access Categories.....	28
13.3	Normal Platform Dimensions	28
14	Reduced Track Centre Signs	31
14.1	Description	31
14.2	Size	32
14.3	Placement	32
14.4	Documentation	32
15	Acceptance Standards	32
15.1	Construction Tolerances at Structures (other than platforms).....	32
15.2	Construction and Maintenance Tolerances at Platforms	32
16	Damage Limits.....	34
Appendix A	Authorised Rolling Stock Outlines	35
Appendix B	Rolling Stock Cross-Sections	43
Appendix C	Definition of Symbols.....	56

1 Purpose, Scope and Application

This standard establishes requirements for Transit Space design.

Transit Space Standards provide for the safe passage of approved trains by providing:

1. various levels of structure gauge based on safety considerations, made up of:
 - A kinematic envelope comprising:
 - Approved rolling stock and loading profiles
 - Track and vehicle tolerances
 - Allowances for curvature and superelevation
 - A safety clearance margin, and
2. minimum infrastructure service requirements for maintainability (eg drainage, mechanised maintenance, service access, increased track centre requirements and electrification).

This standard applies to all Rail Corporation tracks.

2 References

2.1 Australian and International Standards

Nil

2.2 RailCorp Documents

EP 08 00 00 01 SP – Overhead Wiring Standards for the Electrification of New Routes

ESR 0001 – Minimum operating Standards for rolling stock

RSU 110 – Rolling Stock Outline Interface

RSU 130 – Overhead Power Interface

ESC 210 – Track Geometry & Stability

ESC 340 – Tunnels

SPC 213 – Trackside signs

RailCorp Network Rules

RailCorp Design Guidelines for the Upgrade & Construction of New & Existing Train Stabling Yards and Turnback Sidings

2.3 Other References

Nil

2.4 Definitions

Corridor Transit Space Strategy	Operating parameters for a specified line, incorporating business and infrastructure service requirements.
Kinematic Envelope	A two dimensional cross-sectional representation of the swept path of a particular vehicle.
Kinematic Outline	A two dimensional cross-sectional representation of the swept path of all the vehicles authorised at a particular location.

Lading	The cargo carried on or in vehicles, including any fastening systems.
Rolling stock	Any train, track machine, piece of equipment, or lading, which is expected to be on a track, guided by the rails, outside of a worksite.
Rolling stock Outline	The combination of rolling stock cross-section, bogie centres (or wheelbase for non-bogie rolling stock) and body overhang, and rolling stock tolerances, which define the swept path of the rolling stock.
Rolling stock Tolerances	The possible/allowable displacements of the rolling stock from the design rolling stock Outline centred on the guiding wheels. These are described in terms of translations and rotations of rigid bodies relative to infrastructure.
Safety Clearance Margin	The defined clearance beyond the kinematic envelope necessary for safe operation using specified track and rolling stock tolerances.
Service Requirement	The clearance beyond the Safety Clearance Margin that enables defined service tasks to be undertaken.
Structure Gauge	A defined envelope around the track, within which no structure is permitted.
Swept Path	The maximum three dimensional volume taken up by a specified rolling stock Outline (including rolling stock tolerances) as it moves along a track at specified track tolerances, through design curves, transitions etc.
Track Tolerances	The possible displacements of the track from its design track position and gauge.
Transit Space	A clearance envelope that provides for the safe passage of defined rolling stock and for infrastructure service requirements. The Envelope is defined by a Transit Space outline referred to as 'Structure Gauge'.

Symbols used in this standard are defined in Appendix C.

3 Design Requirements

The design, construction and maintenance of all new track, structures and rolling stock, and the maintenance of existing assets shall comply with the following requirements.

3.1 Structure Gauge

All clearances between track and structures, and other tracks, shall meet the requirements of one of the following Structure Gauges:

- Normal Structure Gauge 1994
- General Kinematic Structure Gauge

In circumstances where the requirements of General Kinematic Structure Gauge cannot be met, design approval of the Chief Engineer Track is required. Approval shall be granted by the issuing of a Transit Space Waiver in accordance with the requirements of Section 7.4.

Where major works are being planned that will result in permanent or long term constraints on clearances (e.g. road overbridges, tunnels etc), consideration shall be given to long term corridor strategies.

Where infrastructure is being constructed to meet transit space requirements that will be imposed by the future introduction of larger (wider and/or higher) rolling stock, care is required to minimise the impact of larger than standard clearances (eg platform gaps).

Transit space requirements documented in this standard do not address the aerodynamic affects of train operating through a tunnel. These affects shall be separately considered in the design process.

The applicability of the Structure Gauges is outlined in Section 4.

3.2 Infrastructure Service Requirements

RailCorp's Manager Civil Maintenance shall specify minimum service requirements for the situations listed in Section 6 based on long term corridor strategies. The Minimum Service Requirements shall not infringe the General Kinematic Structure Gauge.

In the absence of any specific requirements, the default minimum dimensions listed in Section 6 shall be adopted.

Any new work or major reconstruction that results in a structure infringing the Minimum Service Requirements, but complying with the General Kinematic Structure Gauge, requires the approval of the relevant Civil Maintenance Engineer.

Any existing location or structure, or minor work of a non-permanent nature carried out on or near an existing location or structure, which infringes the Minimum Service Requirements, but complies with the General Kinematic Structure Gauge requires no authorisation.

3.3 Transit Space Requirements in Stabling Yards and Sidings

The "RailCorp Design Guidelines for the Upgrade & Construction of New & Existing Train Stabling Yards and Turnback Sidings" contain design requirements for stabling yards and turnback sidings that include the requirements for train presentation, train examination, staff access etc. These guidelines shall apply for clearance requirements for staff or train examination.

For Infrastructure Service requirements the clearances detailed in Section 6 shall apply. Variations to the listed default minimum dimensions shall be approved by the Civil Maintenance Engineer on the relevant district or the Civil Maintenance Engineer Infrastructure Facilities.

3.4 Passenger Platforms

Platforms are a critical interface with track. By definition they infringe structure gauge. Design of transit space aspects of platforms shall be in accordance with the requirements of Section 13. Level Access platform design is preferred and shall be applied in all new and reconstructed platform designs.

3.5 Design Physical Interfaces

Approved trackside structures and items of equipment, such as train stops, rail lubricator actuators, contact wires, automatic wagon door openers, buffer stops, checkrails, etc., are essential for system operation and require a physical interface between rolling stock and infrastructure. Other physical interfaces exist where passengers are required to exit

from trains, other than at passenger platforms. These items are permitted to be within the structure gauge. Approved items are detailed in Section 8.

Any item of equipment that is required to physically interface with rolling stock, other than those detailed in Section 8, requires the approval of the Chief Engineer Track.

3.6 Operating Safety Requirements

This standard contains limited information about requirements for "service space" (ie spacial limits and requirements beyond the kinematic envelope) at stations. There are a variety of overlapping requirements for platforms, which must provide public access and safety in addition to considerations for construction and maintenance activities. All proposals for material changes at platforms beyond the kinematic envelope shall be discussed with the Principal Manager Buildings at an early stage to ensure all parameters are taken into account prior to submission to the Configuration Control process

Special requirements exist for clearances adjacent to platforms. These requirements are detailed in Section 9.

3.7 Clearances for Vegetation

The designed placement of vegetation in the rail corridor shall meet the requirements of this standard. The infringement of soft vegetation on Kinematic Structure gauge is not critical, unless it

- interferes with visibility of signals and signs,
- it masks harder obstacles e.g. rock cuttings, or
- it is near a platform where it might interfere with the guard.

4 New Multi-Track Construction

Designers and constructors are to consider the transit space requirements for the maintainability of new multi-track infrastructure and new trackwork in multiple track areas.

Whilst the infrastructure shall be designed to achieve the required levels of reliability and availability, some maintenance may be required to be carried out during normal train operations. This may include track patrol and work to repair points failures.

The requirements for access to safe places when carrying out this maintenance are to be considered during the design phase.

If this is not practical an alternative operational solution will need to be developed and agreed by the relevant stakeholders.

5 Application

The different structure gauges shall be applied as follows. Each allows tighter clearances than the preceding level, with a corresponding increase in either the complexity of the calculation, level of authorisation required, the degree of risk imposed, or the impact of restrictions on the maintainer or operator.

5.1 Normal Structure Gauge 1994 (Including Normal Track Centres)

Applicable to all RailCorp tracks where clearance is available. It provides for ease of use under most circumstances for new construction and includes appropriate infrastructure service requirements as detailed in Section 6. No restrictions are placed on rolling stock operation on corridors carrying any authorised rolling stock outline. It does not require determination of kinematic envelopes.

Calculation of the Normal Structure Gauge 1994 is detailed in Section 7.1.

5.2 General Kinematic Structure Gauge

Applicable to all RailCorp tracks where clearance is available, in circumstances where reduced tolerances apply to some infrastructure service requirements. It is generally applicable to a line section. It requires calculation of the General Kinematic Structure Gauge of each allowable rolling stock outline on a line. It incorporates track and rolling stock tolerances and allowances.

The rolling stock tolerances assume maximum vehicle speed on typical worst-case track condition.

Where reduced tolerances are applied, approval of the Civil Maintenance Engineer is required and special management systems shall be implemented. New designs in platforms shall be registered in accordance with Section 7.3.2

Calculation of the General Kinematic Structure Gauge is detailed in Section 7.2

5.3 Transit Space Waivers

Applicable only in special/restricted circumstances. It is applicable to a specific location only and requires the approval of the Chief Engineer Track. It requires calculation of the Kinematic Structure Gauge of the ACTUAL rolling stock operating on a line to determine the worst-case Kinematic Structure Gauge at a particular location.

It incorporates site specific Track and rolling stock tolerances and may require conditions to be placed on the location or rolling stock such as a reduction in train speeds or an increase in inspection or maintenance.

6 Minimum Infrastructure Service Requirements

The following minimum Infrastructure Service Requirements for the positioning of permanent trackside and overhead structures, and for track centres between adjacent tracks, shall be applied in the absence of specific limits imposed by the Civil Maintenance Engineer.

All dimensions are given relative to the design track centre line horizontal position and height relative to the low rail.

6.1 Horizontal

6.1.1 Main Line

For main line or crossing loops the minimum horizontal dimension between the face of the structure closest to the track and design track centreline shall be as detailed in Table 1.

Note: An allowance for track curvature and superelevation has been included in the clearances listed in Table 1.

Dimension	Structure
2 150mm	Minimum horizontal clearance to structures and structure footings to one metre below design rail level to allow for operation of ballast cleaners. No allowance is required for curve effects.
2 400mm	Signals and associated equipment to enable visibility of signals
3 000mm	OHWS masts and signal bridge masts adjacent to a track Temporary construction works adjacent to a track
3 500mm	Piers, columns, deflection walls between tracks
4 300mm	Bridge substructures and deflection walls (except between tracks) Cuttings without road access Station buildings Columns, footbridges OHWS masts and signal bridge masts on platforms Other structures located adjacent to non-electrified tracks and where road access is not required.
5 000mm	Other structures located adjacent to electrified tracks and where road access is not required
5 500mm	Other Structures and cuttings located adjacent to non-electrified tracks and where road access is required between the structure and the track (Note 1)
6 200mm	Other structures and cuttings located adjacent to electrified tracks and where road access is required between the structure and the track _(Note 1) Bridges or air-space developments where an overhead wiring or signal mast is required within the structure limits

Table 1 – Mainline service requirements

Note 1: The type of vehicles and the intended use of the access road needs to be considered in establishing clearances. If roads are used for maintenance access sufficient clearance is required so that a person can exit the vehicle normally without infringing the "Danger Zone".

6.1.2 Sidings

For structures adjacent to sidings, the minimum horizontal dimension between the face of the structure closest to the track and design track centreline shall be as detailed in Table 2.

Dimension	Structure
2 500mm	Non-continuous structures e.g. isolated columns, overhead wiring masts, doorways and gateways.
3 000mm	Continuous structures, e.g. walls, material stacks and unbroken fencing
3 700mm	Where vehicle doors may open opposite a structure

Table 2 - Siding service requirements

Note: Where structures are located in, or within 22 metres of, curves or turnouts, the clearances nominated in Table 2 shall be increased to allow for track curvature effects by including a centre-throw and end-throw component as detailed in Section 7.1.2.

6.2 Vertical

For all track in **non-electrified** areas the minimum vertical dimension between the underside face of the structure and the design height of the low rail shall be as detailed in Table 3.

Dimension	Rollingstock Outline
5 000mm	Narrow Non-Electric Narrow Square Narrow Container Intersystem Narrow Hopper Out of Gauge Load NZZA Wagon

Table 3 – Vertical clearance requirements in non-electrified areas

For all track in **electrified** areas the minimum vertical dimension between the design **minimum** contact wire height (including maximum sag conditions at worst operating temperatures) and the design **maximum** height of the low rail shall be as detailed in Table 4.

Dimension	Location
5 500mm	Level Crossings (Public or Private)
5 000mm	Other Areas

Table 4 - Vertical clearance requirements to contact wire in electrified areas

Note: The design maximum height of the low rail varies from the design height of the low rail according to the tolerances detailed in Section 11.

For all track in **electrified** areas the minimum vertical dimension between the underside face of non-energised equipment and the design **maximum** height of the low rail shall be as detailed in Table 5.

Dimension	Overhead Wiring Configuration
5 900mm	Wiring Attached
6 500mm	Wiring Not Attached

Table 5 - Vertical clearance requirements to structures in electrified areas

6.3 Track Centres

To provide for service requirements, track centres may be increased to the values below:

Dimension	Application	
6 100mm	for straight tracks.	Main line to Main line
6 200mm	for curved tracks of radius 1000 metres and greater.	Main line to Crossing Loop Main line to Refuge Loop
6 400mm	for curved tracks of radius less than 1000 metres	Main line to Siding Crossing loop to Siding Siding to Siding

Table 6 - Track centres for service requirements

The 6.1, 6.2 and 6.4 metres are based on a space of 600mm for a person standing between 2 tracks with a 700mm clearance to each of the kinematic envelopes.

This distance may be reduced by 500mm if a handrail or other restraint is provided to hold onto.

Note: Track Centres in Train Stabling Yards and Turnback Sidings where cleaning and inspection of RailCorp passenger vehicles is undertaken have special service requirements. The Track Centre requirements in these sidings are detailed in RailCorp Design Guidelines for the Upgrade & Construction of New & Existing Train Stabling Yards and Turnback Sidings.

7 Structure Gauges

7.1 Normal Structure Gauge 1994

Normal Structure Gauge, 1994 is detailed in Figure 1.

7.1.1 Horizontal Clearance

The minimum horizontal dimension from design track centreline to a structure shall be as follows.

Up to a height above design rail height of 3800mm, the minimum horizontal dimension 'A' shall be as detailed in Table 7.

Dimension 'A'	Location
$2060 + M + \frac{E_a Z}{1435}$	on the inside of curves
$2060 + M - \frac{E_a Z}{1435}$	on the outside of curves

Table 7 - Horizontal clearance dimension 'A'

Where Z = the height above design rail height, and

M = a centre-throw and end-throw component as detailed in Section 7.1.2.

The minimum value of dimension 'A' (2060mm) provides safe clearance for the passage of approved rolling stock and loading outlines on straight track. Allowance for curve effects shall be included as shown in Table 7.

7.1.1.1 Electrified Areas

In **electrified** areas the vertical distance from the rail to an item of infrastructure is governed by the height of the contact wire. The contact wire and associated energised electrical equipment are an approved physical interface.

The minimum vertical height (Dimension 'B') of non-energised equipment and other infrastructure above the design height of the low rail shall be 200mm above the highest contact wire position.

The design of overhead wiring shall be in accordance with the requirements of RailCorp Electrical Engineering Standard EP 08 00 00 01 SP.

The minimum value for the vertical dimension from the **lowest** contact wire position to the maximum height of the low rail shall be as detailed in Table 8.

Dimension 'B'	Location
5 400mm	Public Level Crossings
5 000mm	Other Areas (Including Private Level Crossings)

Table 8 - Dimension 'B'

Note: 1. The design contact wire height is determined from the lowest contact wire position by considering worst-case conditions including maximum sag conditions at worst operating temperatures.

The design of overhead wiring shall be in accordance with the requirements of EP 08 00 00 01 SP.

2. The "highest contact wire position" is determined from the "design contact wire height". It shall take into account all allowances for sag being removed, operating temperatures that result in the maximum wire height, and maximum uplift of the wire caused by the maximum upwards thrust imposed by a pantograph according to the limits detailed in RailCorp Rolling Stock Standards ESR 0001 - Minimum Operating Standards for Rolling Stock and RSU 130 - Overhead Power Interface.
3. The design maximum height of the low rail is related to the design height of the low rail according to the tolerances detailed in Section 11.
4. Where the minimum clearances for height in an electrified area detailed above cannot be achieved, an approved electrical design, covering the reduced clearance, must be obtained.

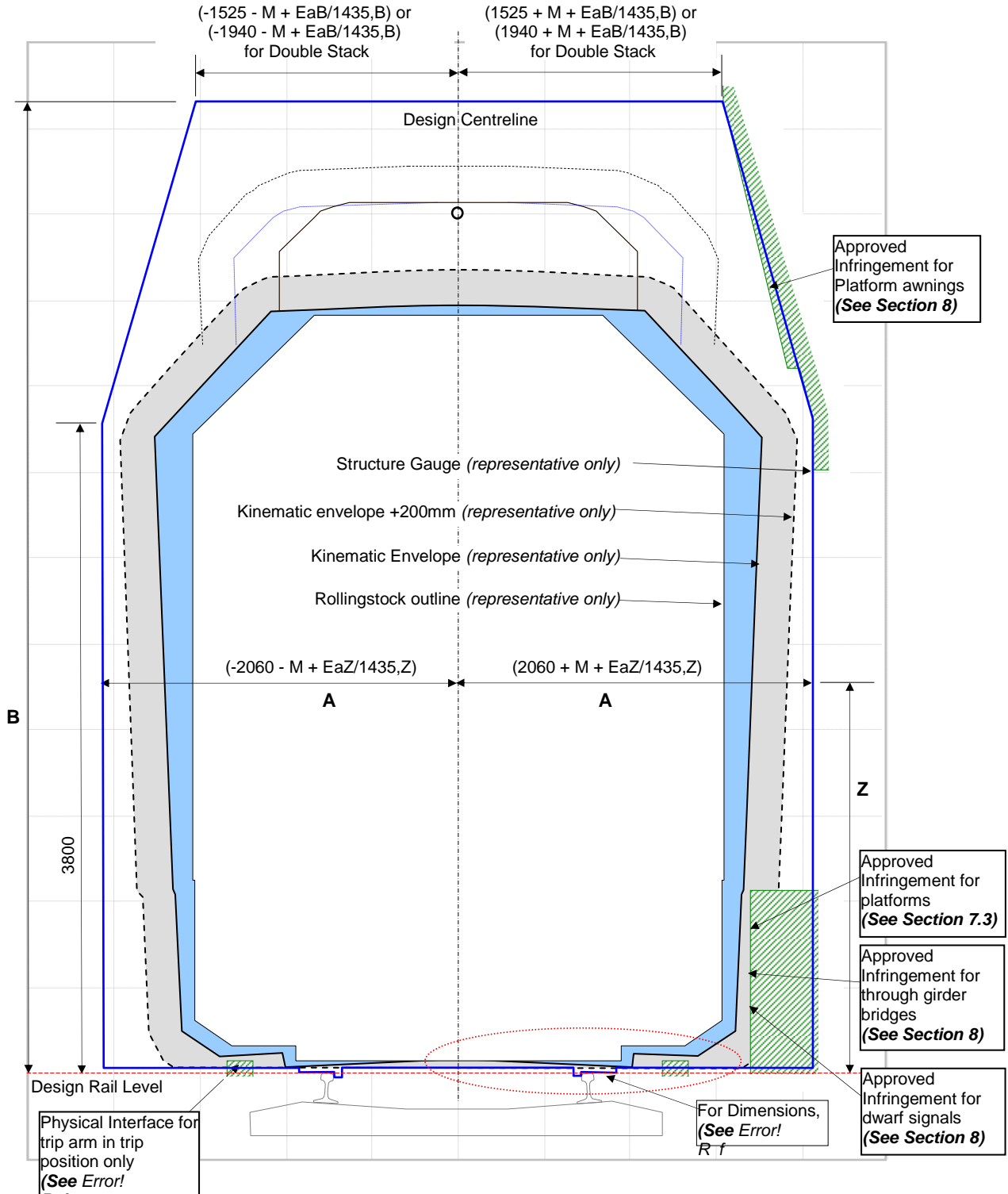

Where:

"Ea" is the Applied Superelevation (right rail in diagram is the low rail).

"B" is the vertical clearance required.

"Z" is the vertical height above the design low rail level.

"M" is the Centre Throw and End Throw component in curves.

For dimensions "B" & "M", see text.

Figure 1 - Normal Structure Gauge 1994

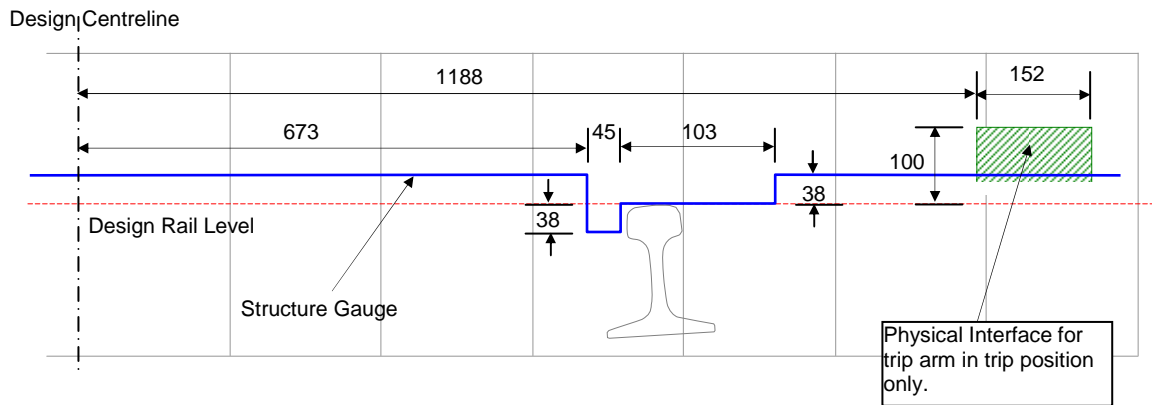

Figure 2 – Structure Gauge Detail at Rail Level

7.1.2 Curve Effects – Value “M” (Centre and End-Throw)

For application of Normal Structure Gauge, 1994, the Centre Throw and End Throw values are assumed to be equal, and are calculated according to the simplified formulae detailed in Table 9 that apply to both concave and convex curves.

Rolling Stock Base Outline	‘M’
Wide Based	$M = \frac{21500}{R}$
Medium Based	$M = \frac{24300}{R}$
Narrow Based	$M = \frac{32600}{R}$

Table 9 – ‘M’ Values

Where: R = Radius of curvature at the location.

7.1.3 Track Centres

Minimum design track centres for new works shall be:

Location	Track Centre Dimensions
Main line to Main line	4000 for straight tracks and for curves $\geq 1000\text{m}$ radius
Main line to Crossing Loop	For curves $< 1000\text{m}$ radius, track centres shall be. If $(E_{a_o} - E_{a_i})$ is positive, $3916 + 2M + 2.5(E_{a_{\text{outside}}} - E_{a_{\text{inside}}})$ If $(E_{a_o} - E_{a_i})$ is negative, $3916 + 2M$
Main line to Refuge Loop	
Siding to Siding (non-examination)	
Main line to Siding	5200 for straight and curved tracks.
Crossing loop to Siding	
Examination Siding	

Table 10 – Track Centres

At locations within yard limits where track centres are less than 4000mm, either between Rail Corporation tracks or between a RailCorp track and an adjacent track a "Narrow Track Centres" sign shall be exhibited.

The purpose of the sign is to warn train operations personnel of the existence of track centres narrower than 4000mm. The required response to the signs by operators is specified in RailCorp Network Rules.

The sign specification and placement requirements are detailed in Section 14.

7.2 General Kinematic Structure Gauge

The General Kinematic Structure Gauge is developed from rolling stock outlines and incorporates track and rolling stock tolerances and allowances and a safety clearance margin. It does not include infrastructure service requirements.

Each rolling stock outline results in a different General Kinematic Structure Gauge that also changes with curve radius and superelevation.

Determination of the transit space requirements for a specific location or a line section will require calculation of the General Kinematic Structure Gauge of all allowable rolling stock outlines for each change in radius or superelevation. The worst case outline shall be applied for each case.

The rolling stock tolerances assume maximum vehicle speed on typical worst-case track condition. Rolling stock tolerances for roll and for bounce are dependent upon vehicle/track interaction.

Select the rolling stock outlines that are approved for operation on the section of track that is being evaluated (See Section 10).

Track tolerances include allowances for lateral, vertical and rotational movement. The default track tolerances are based on ballasted, timber sleepere track in which alignment and top may vary from design over time. Where track is constructed from concrete sleepers, or is fixed on a slab or transom topped bridge, reduced movement is expected and, therefore, reduced track tolerances may be applied. The default and reduced tolerances are detailed in Section 11.

Apply the specific rolling stock tolerances detailed in Section 10.2 and the specific track tolerances detailed in Section 11 to the rolling stock outlines using the method detailed in Section 12.

7.3 Platform Kinematic Structure Gauge

7.3.1 General

To apply the Platform Kinematic Structure Gauge select the rolling stock outlines that are approved for operation on the section of track that is being evaluated (See Section 10).

Select the type of platform (Standards Access or Level Access - see Section 13).

Apply the lateral and vertical clearances specified in Section 13, using the method also detailed in Section 13.

Register the application of the Platform Kinematic Structure Gauge in accordance with the requirements of Section 7.3.2.

7.3.2 Platform Register

The details described in Table 11 shall be provided to the Chief Engineer Track for any new platform design, and when any track redesign is carried out near a platform:

Data	Description	Required
Track Base Code		Mandatory.
Kilometrage	Kilometrage of Station	Mandatory
Station Name		Mandatory
Platform Number		
Rolling stock Outlines	The name of each rolling stock outline considered, from the list of authorised rolling stock outlines in Section □	Mandatory
Height Category	Standard Access or Level Access	Mandatory
Standard followed	Reference to the name and version number of the standard used. i.e. this standard	Mandatory

Table 11 - Register of application of Platform Kinematic Structure Gauge

7.4 Transit Space Waivers

7.4.1 General

Any location or track section failing to comply with the General Kinematic Structure Gauge shall have a waiver approved by the Chief Engineer Track.

The kinematic structure gauge requirements of the waiver shall be developed from the rolling stock outline and incorporates site specific track and rolling stock tolerances and a reduced safety clearance margin. It does not include infrastructure service requirements.

The approval by the Chief Engineer Track may impose special conditions on the waiver, which may include any or all of the following:

- Tighter maintenance limits
- Increased inspection intervals
- Limited duration
- Restricted speed

Register the application of the waiver in accordance with the requirements of Section 7.4.2.

A record of the approval and resulting conditions (if any), shall be maintained by the Civil Maintenance Engineer.

7.4.2 Transit Space Waiver Register

Application for a Transit Space Waiver shall be made to the Chief Engineer Track, and shall provide the details described in Table 12:

Data	Description	Required
Track Base Code		Mandatory
Kilometre Start	Kilometrage of the start location of the track section, or the kilometrage of the discrete location	Mandatory
Kilometre End	Kilometrage of the end location of the track section	Mandatory for track sections
Structure geometry	Horizontal and vertical dimensions of structure from design track centreline	Where appropriate
Track Geometry	Horizontal geometry (i.e. radius, superelevation, location of frame points), track centres, vertical geometry, relative track levels.	Where appropriate
Track Structure	Sleeper type, rail size.	Where appropriate
Operations Description	Rolling stock Outlines, track speed	Where appropriate
Duration for which conditions will apply		Mandatory
Authorised Structure Gauge	The Structure Gauge which is being infringed	Mandatory
Infringement	Magnitude of infringement to Authorised Structure Gauge in mm.	Mandatory

Table 12 – Register of Application of Conditional Kinematic Structure Gauge

8 Physical Interface Requirements

Items of infrastructure that have a physical or operational interface with rolling stock are permitted to be within the structure gauge. These items can only be approved by the Chief Engineer Track.

Items currently approved include:

- Train stops in the trip position
- Rail lubricator actuators
- Contact wires and associated energised electrical equipment
- Automatic wagon door openers in the active position
- Overhead wagon loading structures in the lowered position
- Buffer stops
- Elevated Tunnel Walkways

Where these are installed they shall be designed in accordance with the requirements of RailCorp standard ESC 340. Design Lateral clearance from Track Centre to the edge of the walkway shall be Kinematic Envelope + 100mm..

Maintenance requirements documented in the Technical Maintenance Plan shall include examination of clearance between track and the walkway. The type and frequency of clearance examination shall include consideration of potential for movement of the track structure and the walkway structure.

- Dwarf signals

Dwarf signals are permitted to a maximum height of 1065mm above design rail level. Design Lateral clearance from Track Centre to the edge of the signal shall be Kinematic Envelope + 45mm. Where dwarf signals are placed between tracks, the lateral clearance requirements apply to both tracks.

- Awnings

Awnings are permitted to infringe the structure gauge at platforms. At a height of 4100mm above design rail level they may be placed at a minimum distance from track centre of 1915mm. Where track is curved, appropriate allowances for superelevation and centre and end throw of vehicles shall be applied.

- Through girder underbridges

Through girders on transom topped underbridges are permitted to a maximum height of 1065mm above design rail level. Design Lateral clearance from Track Centre to the edge of the girder shall be Kinematic Envelope + 45mm.

- Speed signs (Permanent and temporary)

In locations where physical constraints prevent placement of speed signs outside Kinematic Envelope + 200, they may be placed so that the closest part of the sign is at Kinematic Envelope + 0.

Speed signs shall not be located in the area required for operating safety requirements detailed in Section 9 below.

Civil Maintenance Engineers shall be notified of any locations where speed signs are located inside Kinematic Envelope + 200.

- Ancillary equipment attached to tunnel walls

At locations where the tunnel outline prevents reasonable compliance with the basic requirements of Kinematic Envelope +200 the minimum lateral clearance from track centre to the edge of cables and related equipment, including troughing and support brackets attached to tunnel walls may be reduced to Kinematic Envelope + 100mm.

The design calculation must consider any future changes in track infrastructure including replating/ rerailing including upgrading to 60kg/m e.g. replacing worn 53kg/m rail and pads with new 60kg/m rail and rail pads will raise the level of the track. If the situation has not been determined a nominal 30mm vertical rise can be assumed to address this

The design calculation shall include all construction tolerances, sag, in-service sag, warping, wind affects etc. that could arise from the relevant equipment.

Any cable locations must consider minimising the space consumed that may be needed for future installation. The position on the tunnel wall should be maintained i.e. the cable should not go up and down as this might minimise the clearance infringement but cause problems for any future cable installation

Otherwise the designer should minimise the infringement below Kinematic Envelope + 200mm.

Civil Maintenance Engineers shall be notified of any locations where equipment is located inside Kinematic Envelope + 200.

9 Operating Safety Requirements

The operation of rollingstock in RailCorp does not normally require train crew to project any part of their bodies outside their train whilst it is travelling. In the area of platforms, however, train crew need to be able to partially extend their bodies outside their train to view passenger activity and receive instructions from platform staff.

Design of infrastructure extending along the track through platforms for a distance of 50m on both the arrival and departure side and vertically from 1200mm to 3200mm above design rail level, shall include a lateral safety clearance margin of 500mm beyond the kinematic outline of the vehicle (instead of the usual 200mm)..

Items of infrastructure that may be affected by this requirement include fencing at platform ends, signals, signs or buildings placed close to the track at the end of stations, etc.

This requirement applies for new designs and for major changes to existing platforms and adjacent infrastructure. The minimum lateral clearance to items of existing infrastructure shall not be less than 350mm.

10 Authorised Rolling Stock Outlines

Table 13 contains a list of the rolling stock outlines that are authorised for operation in RailCorp, the outlines on which they are based, and whether the pantograph outline shall be included with the rolling stock outline. No other rolling stock outlines are permitted.

Rolling stock Outline Name	Base Outline	Pantograph Included	Reference Drawing
Narrow Non-Electric	Narrow	No	Figure 8
Narrow Square	Narrow	No	Figure 9
Narrow Container	Narrow	No	Figure 10
Intersystem	Narrow	No	Figure 11
Narrow Hopper	Narrow	No	Figure 12
Double Stack	Narrow	No	Figure 13
Narrow Electric	Narrow	Yes	Figure 14
Medium Electric	Medium	Yes	Figure 15
Extended Medium Electric	Medium	Yes	Figure 16
Wide Electric ^(Note 1)	Wide	Yes	Figure 17
Out of Gauge Load ^(Note 1)	Narrow	No	Figure 18
NZZA Wagon ^(Note 1)	Narrow	No	Figure 19

Table 13 – Authorised Rolling Stock Outlines

Note: 1. These outlines are to be regarded as desirable. Provision may be made for their operation only when there are no cost or function implications. This provision is applicable at locations where the minimum of Kinematic Envelope + 200mm is achieved for the other outlines.

Appendix A details the rolling stock Outlines approved for operation on each track section on RailCorp's network. This includes details of paths on particular corridors that are to be maintained for Out of Gauge Loads and NZZA Wagons.

NOTE:

Out of Gauge Loads and NZZA Wagons cannot pass Level Access Platforms.

For tracks that are not included in Appendix A, such as loops, sidings, and yards, the rolling stock Outlines authorised on neighbouring tracks shall apply.

Alterations to the outlines and track sections detailed in Appendix A shall only be authorised by the Chief Engineer Track.

Rolling stock Cross-Sections, bogie centres and body overhangs for each rolling stock outline in Table 13 are detailed in Appendix B. The Pantograph Outline for rolling stock is detailed in Appendix B, Figure 20. These dimensions are only to be used in conjunction with the kinematic tolerances detailed in Section 10.2.

10.1 Dynamic Rolling Stock Allowances

This section details rolling stock dimensions and dynamic tolerances that define the swept path of rolling stock outlines for the calculation of Kinematic Structure Gauges.

WARNING:

DO NOT use this information for rolling stock specification or design.

Note 1: Some rolling stock has differing dimensions or tolerances from the standardised rolling stock Outlines, but provide an equivalent swept path to the Authorised rolling stock Outline, and need not be considered separately this standard.

2: Some rolling stock has specially approved items that protrude beyond the standardised rolling stock outline. These are covered by rolling stock Standards, are the responsibility of the rolling stock operators, and are not considered in this standard.

10.2 General Kinematic Tolerances

The rolling stock tolerances in Table 14 shall be used when calculating the General Kinematic Structure Gauge for all authorised rolling stock outlines.

Direction	Relative to	Description	Tolerance
All authorised rolling stock outlines except “NZZA Wagon”			
Lateral	Relative to the plane of the Superelevation (with any superelevation variation applied)	Body to Wheelset	± 60mm total
		Wheel Wear	
		Wheel/Rail free-play	
		Extra Clearance	+ 200mm ^(Note 1)
Vertical	Relative to the displaced vehicle centreline	Bounce Upwards	+ 50mm
		Bounce Downwards	- 0mm
		Extra Clearance Upwards	+ 100mm
		Extra Clearance Downwards	- 0mm
Rotational	Roll about the displaced roll centre of the rolling stock Outline	<i>Note: the roll centre moves laterally and vertically with the rolling stock outline</i>	± 2°
“NZZA Wagon” outline			
Lateral	Relative to the plane of the Superelevation (with any superelevation variation applied)	Body to Wheelset	± 25mm total
		Wheel Wear	
		Wheel/Rail free-play	
		Extra Clearance	+ 200mm ^(Note 1)
Vertical	Relative to the displaced vehicle centreline	Bounce Upwards	+ 0mm
		Bounce Downwards	- 0mm
		Extra Clearance Upwards	+ 100mm
		Extra Clearance Downwards	- 0mm
Rotational	Roll about the displaced roll centre of the rolling stock Outline		± 1°

Table 14 – Rolling Stock Tolerances

Note 1: For existing tracks when considering the clearance impact of rolling stock using the turnout route of a turnout on the adjoining track centres the extra clearance may be reduced to 50mm. This is in recognition of the current situation where existing track centres have not considered the impact of trains utilising the turnout road on an adjacent track. (the clearance conflict is illustrated in Figure 3 below). The following conditions apply to the application of the reduced limit;

1. The reduced clearance limit has the status of a maximum/ minimum limit where the normal limit is to remain as 200mm extra lateral clearance. Designers shall provide justification for not using the normal limits (as with other design parameters).
2. It is only applicable for the assessment of existing turnouts or for turnout renewals where the constraint is derived from current track design track centres.
3. All other tolerances shall to be applied
4. All applicable rolling stock envelopes shall be considered.

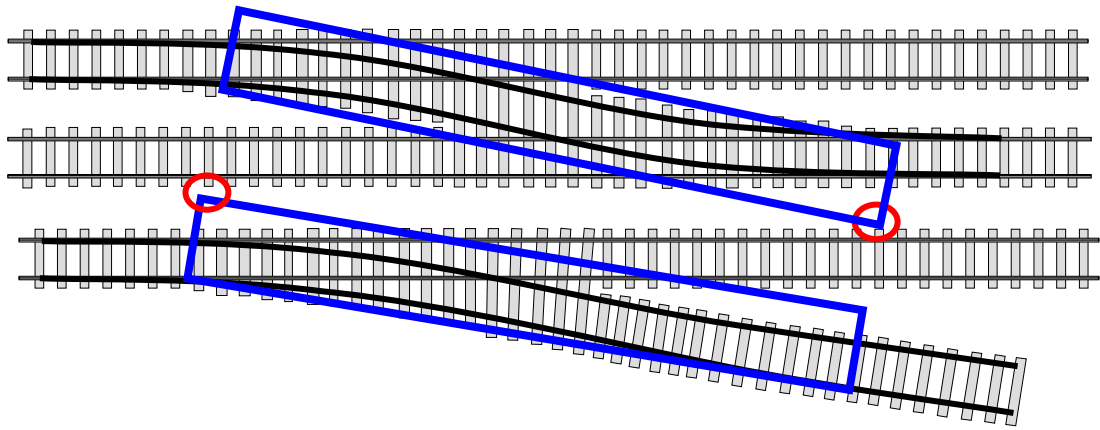

Figure 3 – Clearance conflicts for trains using turnout road on adjacent tracks highlighted by red circle

11 Track Tolerances

11.1 Open track

This section details the tolerances to be included when calculating the various Kinematic Structure Gauges to allow for variation of track from design.

Note: Track tolerances used in the calculation of Kinematic Structure Gauges may differ from those imposed for design or maintenance of track. They represent average figures. They shall not be used for purposes other than stated here.

The track tolerances detailed in Table 15 shall be used for all authorised rolling stock outlines, when calculating the General Kinematic Structure Gauge:

Direction	Description	Relative to		Tolerance
Timber sleepersed ballasted track				
Lateral	Rail Variation	Rail Wear		15mm
	Alignment	Horizontal difference from design	Curves > 2000m radius and tangent	± 25mm
			curves ≤ 2000m radius	± 35mm
Vertical	Level	Difference from design		+100mm - 150mm
Rotational	Superelevation	Difference from design		± 10mm
Concrete sleepersed track				
Lateral	Rail Variation	Rail Wear		15mm
	Alignment	Horizontal difference from design	curves > 2000m radius and tangent	± 15mm
			curves ≤ 2000m radius	± 25mm
Vertical	Level	Difference from design		+100mm - 150mm
Rotational	Superelevation	Difference from design		± 10mm
Slab track and Transom Top Bridges				
Lateral	Rail Variation	Rail Wear		15mm
	Alignment	Horizontal difference from design	curves > 2000m radius and tangent	± 10mm
			curves ≤ 2000m radius	± 20mm
Vertical	Level	Difference from design		± 50mm
Rotational	Superelevation	Difference from design		± 10mm

Table 15 – Track tolerances for slab track and transom top bridges

11.2 Platforms

See Section 13.

12 Method of Calculation of Kinematic Structure Gauges

12.1 General

This Section details the method to be used to apply track and rolling stock tolerances to a particular rolling stock outline, at a particular track location, in order to determine the General Kinematic Structure Gauge.

The Kinematic Envelope is the outline generated by a moving vehicle, taking into account vehicle and track effects as listed in Sections 10 and 11.

A different Kinematic Envelope shall apply for each rolling stock outline.

At any particular location, the kinematic structure gauge is the maximum envelope created by superimposing the kinematic envelopes of all rolling stock outlines authorised to pass that location.

12.2 Calculation of Kinematic Envelope

The track and rolling stock tolerances are applied to the rolling stock Cross-Section relative to the reference plane specified.

- All Lateral rolling stock tolerances and centre and end throw are applied relative to the coordinate system of the wheelset, which follows the plane of the superelevation (including superelevation tolerances).
- All Rotational rolling stock tolerances are applied about the roll centre, which is fixed to the coordinate system of the rolling stock Outline, which shifts laterally relative to the wheelset.
- All Vertical rolling stock tolerances are applied relative to the coordinate system of the rolling stock Outline, which rolls and shifts laterally relative to the wheelset.
- All Lateral Alignment Track Tolerances are applied relative to horizontal.
- Lateral Track Tolerances caused by variation in the rail are applied relative to the plane of the superelevation. For the purposes of General Kinematic Structure Gauge, these tolerances have been included in the Lateral Rolling Stock Tolerances.
- All Vertical Track Tolerances are applied relative to horizontal.
- All Rotational Track Tolerances and the design Superelevation are applied relative to horizontal.

The order in which these are applied is unimportant, provided that the tolerances are applied relative to their correct reference body.

12.2.1 Centre and End Throw

Centre and end throw of vehicles may be calculated as follows:

$$C_t = \frac{B_c^2}{8R}$$

$$E_t = \frac{L^2}{8R + 4W} - C_t$$

- where
- C_t = centre throw of nominated vehicle in mm.
 - E_t = end throw of nominated vehicle in mm.
 - B_c = bogie centres of nominated vehicle in mm
 - R = radius of curve in mm.
 - L = length of nominated vehicle in mm. (where $L = B_c + 2B_o$)
 - B_o = body overhang of nominated vehicle in mm
 - W = width of nominated vehicle in mm.

- Note:
1. Simplified formulae for Centre and End Throw are used in Section 7.1.2 for the calculation of Normal Structure Gauge 1994.
 2. Centre and End Throw is not to be applied to the areas on the rolling stock outline designated "Outline Extension for Bogie Components Only", "Physical

Interface for Wheels Only”, and “Physical interface for Trip Valve Arm Only”, as these areas are restricted to the region of the bogie.

12.2.2 Pantograph Kinematic

Table 13 indicates when a Pantograph Outline is to be included with the rolling stock outline.

For these rolling stock outlines, position the “Maximum Pantograph Outline”, Appendix B, Figure 20 on top of the rolling stock outline such that the pantograph moves laterally and rotates with the rolling stock outline (including the Extra Lateral Clearance from Section 10.2 but excluding Bounce.)

The pantograph moves vertically along the rolling stock centreline to a height equal to the highest contact wire position plus an uplift of 75mm. The highest contact wire position is wholly dependent on the design of the overhead wiring and support structures and shall be determined in accordance with EP 08 00 00 01 SP,

- Note:
1. Contact wire height is usually referenced relative to the centreline of the track. If structure dimensions are referenced to the height of the low rail, the corresponding contact wire height shall be increased by half the superelevation.
 2. A further vertical clearance of 150mm is required above the pantograph in this position.

12.3 Kinematic Track Centres

The Kinematic Track Centre is determined by superimposing the Kinematic Envelopes of all authorised rolling stock outlines on each track, noting that the worst case may be the centre throw of one vehicle with the end throw of a different vehicle. Extra Clearances of rolling stock on adjacent tracks are permitted to overlap. (i.e. the Extra Lateral Clearance need only be applied to the Kinematic Envelopes calculated on one of the tracks.)

The following rolling stock Outlines operate under the restriction of having no trains on adjacent tracks and therefore do not need to be considered in the calculation of Kinematic Track Centres:

- Out of Gauge Load Outline
- NZZA Wagon

13 Calculation of Platform Kinematic Structure Gauge

13.1 General

This method summarises and simplifies the Kinematic Structure Gauge for platforms.

Platforms designed for Wide Electric rolling stock shall also be checked for Extended Medium, Medium and Narrow rolling stock, which may require more clearance in some situations due to their greater bogie centres and body overhang. Platforms designed for Extended Medium and Medium Electric rolling stock shall also be checked for Narrow rolling stock.

Some tracks are authorised for the operation of “Out of Gauge Load Outline” and “NZZA Wagon”. Level Access platforms SHALL NOT be constructed adjacent to these tracks.

Platforms are the only structures authorised to be built to the Platform Kinematic Structure Gauge. Other structures in the vicinity of platforms SHALL NOT use the Platform Kinematic Structure Gauge.

13.2 Platform Access Categories

Platforms may be designated:

Standard Access provides a step down of approximately 150mm from car floor to platform coping.

Level Access is at approximately the same level as the car floor.

13.3 Normal Platform Dimensions

13.3.1 Platform Heights

13.3.1.1 Standard Access

The height V_s , to a platform coping above Design Rail Level for varying rolling stock outlines on straight track shall be as detailed in Table 16.

The height to a platform coping above Design Rail Level (low rail) on curved track shall be:-

$$V_c = V_s + 1.7E_a \text{ for a concave platform}$$

$$V_v = V_s - 0.7E_a \text{ for a convex platform}$$

Where E_a = Design superelevation at the point in the track being analysed.

13.3.1.2 Level Access

The height V_L , to a platform coping above Design Rail Level for varying rolling stock outlines on straight track shall be as detailed in Table 16.

The height to a platform coping above Design Rail Level (low rail) on curved track shall be:-

$$V_{Lc} = V_L + 1.7E_a \text{ for concave platform.}$$

$$V_{Lv} = V_L - 0.7E_a \text{ for a convex platform.}$$

Where E_a = Design superelevation at the point in the track being analysed.

13.3.2 Platform Lateral Clearances

13.3.2.1 Standard Access

The horizontal clearance H_s between a straight Standard Access platform coping edge and the design centreline of the adjacent track is shown in Table 16 and Figure 4.

Rolling Stock Type	Sleeper Type	H _s (mm)	H _L (mm)	K	k	V _s (mm)	V _L (mm)
Narrow Based	All	1575	1590	32600	0.67	1065	1200
Medium Electric	All	1650	1665	24300	0.75		
Extended Medium	Timber	1650	1680	24300	0.75		
Extended Medium	Concrete	1650	1665	24300	0.75		
Wide Electric	All	1700	1715	21500	0.75		
ANZR	All	1700	1715	42000	0.75		

Table 16 – Platform clearance dimensions

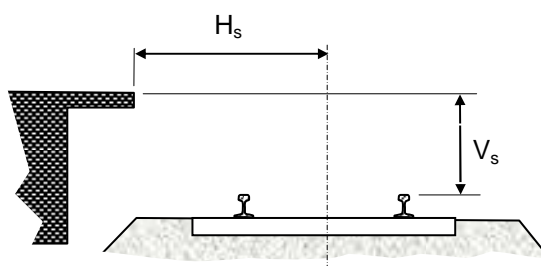

Figure 4 – Platform clearances on tangent track

13.3.2.2 Level Access

The horizontal clearance H_L between a straight Level Access platform coping edge and the design centreline of the adjacent track is shown in Table 16.

13.3.2.3 Curved Track

The horizontal clearance to concave and convex Standard Access platforms is shown in Figure 5 by H_c and H_v respectively as follows:

$$H_c = H_s + \frac{K}{R} - kE_a \quad \text{for concave platform}$$

$$H_v = H_s + \frac{K}{R} + kE_a \quad \text{for convex platform}$$

The horizontal clearance to Level Access platforms is found by substituting H_L for H_s in the above formulae.

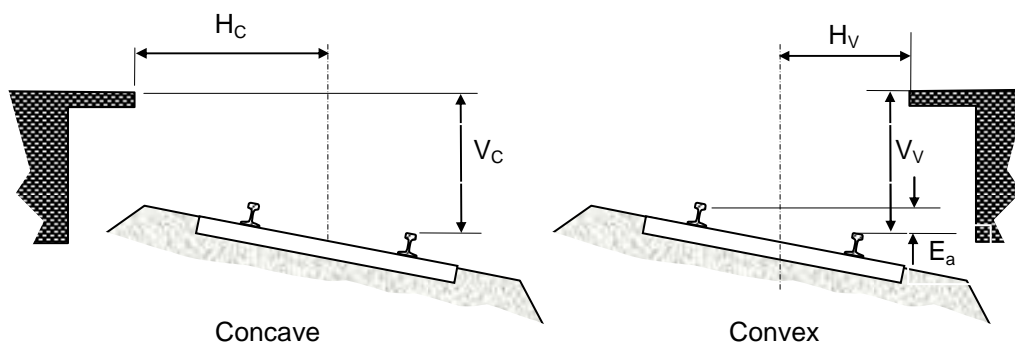

Figure 5 – Platform clearances on curved track

13.3.2.4 Transitioned Track

Determination of the clearances to platforms adjacent to transition curves, or within a vehicle length of a transition curve is complex, being a function of the radii and superelevation of the track at both bogies of the relevant vehicle. Three dimensional modelling is preferred for all new designs. Methods of calculation shall be approved by the Chief Engineer Track. Note that 3D modelling is not dynamic modelling.

The following simplified formulae provide automatic smoothing of geometries and may be used for simple geometric situations and where there are gradual changes in geometry. They should not be used if there are multiple geometric segments within "L".

The radius used is the effective radius at the point in the track being analysed, and the superelevation used is the effective superelevation at the point in the track being analysed.

$$H_C = H_S + \frac{K}{R_e} - kE_{a_e} \quad \text{for concave platform.}$$

$$H_V = H_S + \frac{K}{R_e} + kE_{a_e} \quad \text{for convex platform.}$$

The effective superelevation (E_{a_e}) for a **concave** platform is the average superelevation of two points on the track, which are a distance of $\frac{L+B_c}{2}$ and $\frac{L-B_c}{2}$, in the direction of increasing superelevation, from the point in the track being analysed.

The effective superelevation (E_{a_e}) for a **convex** platform is the average superelevation of two points on the track, which are a distance of $\frac{B_c}{2}$, in each direction, from the point in the track being analysed.

The effective radius (R_e) for a **concave** platform is the average radius of two points on the track, which are a distance of $\frac{L+B_c}{2}$ and $\frac{L-B_c}{2}$, in the direction of tightening radius, from the point in the track being analysed.

The effective radius (R_e) for a **convex** platform is the average radius of two points on the track, which are a distance of $\frac{B_c}{2}$, in each direction, from the point in the track being analysed.

The average radius of two points can be determined using the following formula:

$$R_e = \frac{2}{\left(\frac{1}{R_1} + \frac{1}{R_2}\right)}$$

Where R_1 and R_2 are the radii at each of the two points.

E_a and R at any point in a transition can be determined from formulae provided in ESC 210.

The horizontal clearance to Level Access platforms is found by substituting H_L for H_s in the above formulae.

13.3.2.5 Non-Transitioned Curves

The clearances to platforms adjacent to non-transitioned curves, or within a vehicle length of a non-transitioned curve, are considered complex situations and shall only be determined by use of approved 3D modelling techniques.

14 Reduced Track Centre Signs

The purpose of the sign is to warn train operations personnel of the existence of track centres narrower than 4000mm. The required response to the signs by operators is specified in RailCorp Network Rules.

Reduced Track Centre signs shall be manufactured in accordance with the requirements of RailCorp Specification SPC 213 – Trackside signs

14.1 Description

The signs contain the words “Danger Narrow Track Clearances” in black text on a white background as shown in Figure 6.



Figure 6 – Narrow Track Clearances Sign

14.2 Size

Where signs are provided at entry points to yards/sidings, they shall to be 600 mm wide x 400mm high.

Where signs are provided at point levers or main frame levers, they shall be 400 mm wide x 300mm high.

14.3 Placement

The number and location of signs within a yard shall be determined by a risk assessment. The minimum requirement is 2 signs, one at each end.

Signs shall to be positioned:

- At least 2.2m above rail level (centre of sign)
- Clear of structure gauge
- To be clearly visible to train operations personnel
- So as not to be associated with any signals
- So as not to restrict the operator's normal field of vision or operation of levers
- So as not to present a tripping hazard, or a head or body collision hazard to personnel

14.4 Documentation

The positioning of all signs is to be documented on the applicable track layout diagram.

15 Acceptance Standards

15.1 Construction Tolerances at Structures (other than platforms)

Physical construction of structures adjacent to track infrastructure shall not reduce the transit space safety margins. Design of structures shall consider construction tolerances when establishing clearance requirements.

15.2 Construction and Maintenance Tolerances at Platforms

The tolerances detailed in Table 17 apply to the construction or renewal of platforms and the construction, renewal or maintenance of track through platforms.

	Tolerances (mm)		Comments
	Standard Access	Level Access	
Height tolerance			
Construction or renewal of platforms	- 0 to + 25	± 10 ^(Note 1)	Relative to design rail level. (See Figure 7)
Construction or renewal of track at platforms	- 0 to + 50	± 15	Relative to design rail level. (See Figure 7)
Maintenance of track at platforms	- 0 to + 50	- 25 to + 15	Relative to design rail level. (See Figure 7) (See Note 2)
Lateral clearance tolerance			
Construction or renewal of platforms	- 0 to + 5		Relative to design alignment. (See Figure 7)
Construction of track at platforms	± 6 mm		Relative to design track alignment.
Maintenance or renewal of track at platforms	± 15 mm		Relative to actual track alignment.
Superelevation tolerance			
Construction or renewal of track at platforms	± 5 mm		Relative to design superelevation
Maintenance of track at platforms	± 6 mm		Relative to of design superelevation

Table 17 – Construction and maintenance tolerances at platforms

- Note
1. ± 5 mm preferred where practical
 2. Over time the track level will rise as a result of maintenance resurfacing. When track maintenance is carried out any lifts that will take the rail level above the tolerances should be minimised.

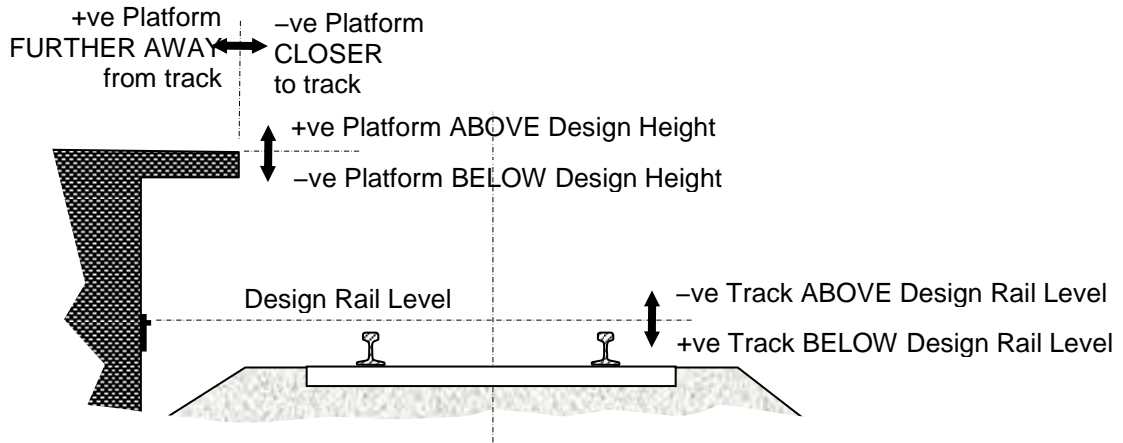

Figure 7 – Measurement Conventions

16 Damage Limits

To be determined

Appendix A Authorised Rolling Stock Outlines

Authorised Rolling Stock Outlines on Track Sections																			
Legend																			
Y	The Outline is authorised to operate, and shall be considered when designing or maintaining the Infrastructure.					S	The Outline is authorised for single line working only. It does not need to be considered when designing or maintaining track centres but it shall be considered when designing or maintaining all other Infrastructure.												
P	The Outline is not currently authorised, but is planned to be authorised, and shall be considered when designing or maintaining the Infrastructure.					T	The Outline is authorised under restricted operating conditions. It does not need to be considered when designing or maintaining any Infrastructure or track centres.												
R	The Outline is authorised but has restricted operating conditions through platforms. It does not need to be considered when designing or maintaining platforms but it shall be considered when designing or maintaining other Infrastructure.					N	The Outline is not authorised , and does not need to be considered when designing or maintaining the Infrastructure.												
Base Code	Track Name	From			To			Rolling stock outlines											
		km	Track Location	Location Description	km	Track Location	Location Description	Narrow Non-Electric	Narrow Square	Narrow Container	Intersystem	Narrow Hopper	Double Stack	Narrow Electric	Medium Electric	Extended Medium	Wide Electric	Out of Gauge Load	NZZA Wagon
10001	Main North, Up	12.020	Strathfield	538A Points	48.814	Cowan	Signal C21UM	Y	Y	Y	Y	Y	N	Y	Y	Y	R	S	S
10001	Main North, Up	48.814	Cowan	Signal C21UM	65.000	Wondabyne	2A Points	Y	Y	Y	Y	Y	N	Y	Y	T	N	S	S
10001	Main North, Up	65.000	Wondabyne	2A Points	72.600	Woy Woy	2B Points	Y	Y	Y	Y	Y	N	Y	Y	T	N	N	N
10001	Main North, Up	72.600	Woy Woy	2B Points	163.680	Woodville Junction	42A Points	Y	Y	Y	Y	Y	N	Y	Y	T	N	S	S
10002	Main North, Down	11.600	Strathfield	541 Points	48.814	Cowan	Signal C19DM	Y	Y	Y	Y	Y	N	Y	Y	Y	R	S	S
10002	Main North, Down	48.814	Cowan	Signal C19DM	163.680	Woodville Junction	40A Points	Y	Y	Y	Y	Y	N	Y	Y	T	N	S	S
10011	Main North, Suburban Down	11.920	Strathfield	535 Points	12.600	Strathfield	553B Points	Y	N	Y	N	Y	N	Y	Y	Y	R	N	N
10012	Main North, Suburban Up	11.630	Strathfield	532A Points	12.570	Strathfield	550 Points	Y	N	Y	N	Y	N	Y	Y	Y	R	N	N
10013	Main North, Suburban Down	19.310	West Ryde	101 Points	23.970	Epping	109B Points	Y	Y	Y	Y	Y	N	Y	Y	Y	R	S	S
10014	Main North, Suburban Up	18.830	West Ryde		23.150	Epping	103B Points	Y	Y	Y	Y	Y	N	Y	Y	Y	R	S	S
10028	North Shore, Down	0.000	Central	0km Platform 16	25.200	Hornsby	79 A Points	Y	N	Y	N	Y	N	Y	Y	Y	R	N	N
10029	North Shore, Up	0.000	Central	0km Platform 18	25.000	Hornsby	83A Points	Y	N	Y	N	Y	N	Y	Y	Y	R	N	N
10043	Main South, Down	16.740	Lidcombe	713 Points	28.200	Cabramatta	121 Points	Y	Y	Y	Y	Y	N	Y	Y	Y	R	S	S
10044	Main South, Down	31.770	Cabramatta	121 Points	56.570	MacArthur	Goulburn end of platform	Y	Y	Y	Y	Y	N	Y	Y	Y	R	S	S
10044	Main South, Down	56.570	MacArthur	Goulburn end of platform	60.000	Glenlee Jct	61 points	Y	Y	Y	Y	Y	N	Y	T	T	T	S	S
10046	Main South, Up	16.740	Lidcombe	714 Points	28.240	Cabramatta	122 Points	Y	Y	Y	Y	Y	N	Y	Y	Y	R	S	S
10047	Main South, Up	31.810	Cabramatta	122 Points	56.570	MacArthur	Goulburn end of platform	Y	Y	Y	Y	Y	N	Y	Y	Y	R	S	S
10047	Main South, Up	56.570	MacArthur	Goulburn end of platform	60.000	Glenlee Jct	60 points	Y	Y	Y	Y	Y	N	Y	T	T	T	S	S
10078	Moss Vale – Down Main	87.854	Unanderra	1106 Points	91.080	Unanderra	ARTC boundary	Y	Y	Y	Y	Y	N	N	N	N	N	S	S
10079	Moss Vale – Up Main	87.757	Unanderra	1105A Points	91.080	Unanderra	ARTC boundary	Y	Y	Y	Y	Y	N	N	N	N	N	S	S
10081	East Hills Down & Local Down	8.300	Turrella	500B Points	32.398	Glenfield North Jct	43 Points	Y	Y	Y	N	Y	N	Y	Y	Y	R	S	N

Authorised Rolling Stock Outlines on Track Sections

Legend

Y	The Outline is authorised to operate, and shall be considered when designing or maintaining the Infrastructure.	S	The Outline is authorised for single line working only. It does not need to be considered when designing or maintaining track centres but it shall be considered when designing or maintaining all other Infrastructure.
P	The Outline is not currently authorised, but is planned to be authorised, and shall be considered when designing or maintaining the Infrastructure.	T	The Outline is authorised under restricted operating conditions. It does not need to be considered when designing or maintaining any Infrastructure or track centres.
R	The Outline is authorised but has restricted operating conditions through platforms. It does not need to be considered when designing or maintaining platforms but it shall be considered when designing or maintaining other Infrastructure.	N	The Outline is not authorised , and does not need to be considered when designing or maintaining the Infrastructure.

Base Code	Track Name	From			To			Rolling stock outlines											
		km	Track Location	Location Description	km	Track Location	Location Description	Narrow Non-Electric	Narrow Square	Narrow Container	Intersystem	Narrow Hopper	Double Stack	Narrow Electric	Medium Electric	Extended Medium	Wide Electric	Out of Gauge Load	NZZA Wagon
10082	East Hills Up & Local Up	8.215363	Turrella	500A Points	32.214	Glenfield North Jct	41 Points	Y	Y	Y	N	Y	N	Y	Y	Y	R	S	N
10087	Bankstown Line, Down	5.110	Sydenham	737A Points	22.730	Sefton Park East Jct	38 Points	Y	Y	Y	N	Y	N	Y	Y	Y	R	S	S
10088	Bankstown Line, Up	5.110	Sydenham	738A Points	22.730	Sefton Park East Jct	43 Points	Y	Y	Y	N	Y	N	Y	Y	Y	R	S	S
10089	Botany Line Down & Single Line	10.410	ARTC boundary	ARTC boundary	16.472	Marrickville Jct	779 Points	Y	Y	Y	N	Y	N	N	N	N	S	S	S
10090	Botany Line Up	14.698	Cooks River	Points? TLI	16.469	Marrickville Jct	780 Points	Y	Y	Y	Y	Y	N	N	N	N	S	S	S
10091	Metrop Goods Down (South Fork)	5.420	Meeks Road Jct	746 Points	6.064	Meeks Road Jct	773 Points West Jct	Y	Y	Y	Y	Y	N	Y	S	S	S	S	S
10092	Metropolitan Goods, Down	6.060	Meeks Road Jct	774 Points West Jct	13.500	Enfield	300 Points	Y	Y	Y	Y	Y	N	Y	S	S	S	S	S
10092	Metropolitan Goods, Down	13.500	Enfield	300 Points	20.328	Lidcombe	697 Points	Y	Y	Y	Y	Y	N	Y	Y	Y	S	S	S
10093	Metrop Goods Up (South Fork)	5.421	Meeks Road Jct	747 Points	6.064	Meeks Road Jct	774 Points West Jct	Y	Y	Y	Y	Y	N	Y	S	S	S	S	S
10094	Metropolitan Goods, Up	6.060	Meeks Road Jct	774 Points West Jct	13.500	Enfield	300 Points	Y	Y	Y	Y	Y	N	Y	S	S	S	S	S
10094	Metropolitan Goods, Up	13.500	Enfield	300 Points	20.328	Lidcombe	697 Points	Y	Y	Y	Y	Y	N	Y	Y	Y	S	S	S
10095	Rozelle Line, Up	7.850	Wardell Rd East Jct	141 Points	8.510	Hercules St Jct	147 Points	Y	Y	Y	Y	Y	N	Y	N	N	S	S	S
10096	Rozelle Line, Down	7.850	Wardell Rd East Jct	140 Points	8.510	Hercules St Jct	146 Points	Y	Y	Y	Y	Y	N	Y	N	N	S	S	S
10097	Rozelle Line, Up	8.290	Wardell Rd West Jct	143 Points	8.500	Hercules St Jct	146 Points	Y	Y	Y	Y	Y	N	Y	N	N	S	S	S
10097	Rozelle Line, Up	8.500	Hercules St Jct	146 Points	13.340	Balmain Rd Jct	14B Points	Y	N	Y	N	Y	N	Y	N	N	S	S	S
10098	Rozelle Line, Down	8.290	Wardell Rd West Jct	142 Points	8.500	Hercules St Jct	143 Points	Y	Y	Y	Y	Y	Y	N	N	N	S	S	S
10098	Rozelle Line, Down	8.500	Hercules St Jct	143 Points	13.370	Balmain Rd Jct	27 Points	Y	N	Y	N	Y	N	Y	N	N	S	S	S
10099	Main West, Suburban Down	21.540	Granville	711A Points	47.650	St Marys	809 Points	Y	Y	Y	N	Y	N	Y	Y	Y	R	S	S
10100	Main West, Suburban Up	21.560	Granville	712A Points	47.660	St Marys	810 Points	Y	Y	Y	N	Y	N	Y	Y	Y	R	S	S
10101	Suburban, Down	0.000	Central	0km Platform 18	12.570	Homebush	601B Points	Y	Y	Y	N	Y	N	Y	Y	Y	R	N	N
10101	Suburban, Down	12.570	Homebush	601B Points	21.470	Granville	708A Points	Y	Y	Y	N	Y	N	Y	Y	Y	R	S	S
10102	Suburban, Up	0.000	Central	0km Platform 16	12.570	Homebush	600B Points	Y	Y	Y	N	Y	N	Y	Y	Y	R	N	N
10102	Suburban, Up	12.570	Homebush	600B Points	21.470	Granville	709 Points	Y	Y	Y	N	Y	N	Y	Y	Y	R	S	S

Authorised Rolling Stock Outlines on Track Sections

Legend

Y	The Outline is authorised to operate, and shall be considered when designing or maintaining the Infrastructure.	S	The Outline is authorised for single line working only. It does not need to be considered when designing or maintaining track centres but it shall be considered when designing or maintaining all other Infrastructure.
P	The Outline is not currently authorised, but is planned to be authorised, and shall be considered when designing or maintaining the Infrastructure.	T	The Outline is authorised under restricted operating conditions. It does not need to be considered when designing or maintaining any Infrastructure or track centres.
R	The Outline is authorised but has restricted operating conditions through platforms. It does not need to be considered when designing or maintaining platforms but it shall be considered when designing or maintaining other Infrastructure.	N	The Outline is not authorised , and does not need to be considered when designing or maintaining the Infrastructure.

Base Code	Track Name	From			To			Rolling stock outlines											
		km	Track Location	Location Description	km	Track Location	Location Description	Narrow Non-Electric	Narrow Square	Narrow Container	Intersystem	Narrow Hopper	Double Stack	Narrow Electric	Medium Electric	Extended Medium	Wide Electric	Out of Gauge Load	NZZA Wagon
10103	Main, Down	0.000	Central	0km Platform 2	12.570	Homebush	601A Points	Y	P	Y	N	Y	N	Y	Y	Y	R	N	N
10103	Main, Down	12.570	Homebush	601A Points	21.540	Granville	711A Points	Y	Y	Y	N	Y	N	Y	Y	Y	R	S	S
10104	Main, Up	0.000	Central	0km Platform 1	12.570	Homebush	600A Points	Y	Y	Y	N	Y	N	Y	Y	Y	R	N	N
10104	Main, Up	12.570	Homebush	600A Points	21.560	Granville	712A Points	Y	Y	Y	N	Y	N	Y	Y	Y	R	S	S
10105	Local, Down	0.000	Central	0km Platform 19	12.570	Homebush	603 Points	Y	P	Y	N	Y	N	Y	Y	Y	R	N	N
10106	Local, Up	0.000	Central	0km Platform 17	12.570	Homebush	603 Points	Y	P	Y	N	Y	N	Y	Y	Y	R	N	N
10107	Granville to Cabramatta, Main Down	21.470	Granville	708A Points	31.770	Cabramatta	121 Points	Y	Y	Y	Y	N	Y	Y	Y	Y	R	S	S
10108	Granville to Cabramatta, Main Up	21.470	Granville	709 Points	31.810	Cabramatta	122 Points	Y	Y	Y	Y	N	Y	Y	Y	Y	R	S	S
10109	South West Outer, Loop Triangle	21.610	Harris Park	715 Points	22.810	Merrylands	756 Points Outer	Y	N	Y	N	Y	N	Y	Y	Y	R	S	S
10110	South West Inner, Loop Triangle	21.460	Harris Park	717 Points	22.820	Merrylands	757 Points Inner	Y	N	Y	N	Y	N	Y	Y	Y	R	S	S
10111	Illawarra, Local Down	0.000	Central	0km Platform 22	6.500	Tempe	746B Points	Y	N	Y	N	Y	N	Y	Y	Y	R	N	N
10111	Illawarra, Local Down	6.500	Tempe	746B Points	15.057	Hurstville	985C Points	Y	Y	Y	N	Y	N	Y	Y	Y	R	S	S
10112	Illawarra, Local Up	0.000	Central	0km Platform 20	6.500	Tempe	746B Points	Y	N	Y	N	Y	N	Y	Y	Y	R	N	N
10112	Illawarra, Local Up	6.500	Tempe	746B Points	15.622	Hurstville	991B Points	Y	Y	Y	N	Y	N	Y	Y	Y	R	S	S
10113	Illawarra, Main Down	0.510	Central	633 Points start of Illa Dn	6.600	Tempe	749B Points	Y	Y	Y	N	Y	N	Y	Y	Y	R	N	N
10113	Illawarra, Main Down	6.600	Tempe	749B Points	46.585	Helensburgh	WG747D Signal	Y	Y	Y	N	Y	N	Y	Y	Y	R	S	S
10113	Illawarra, Main Down	46.585	Helensburgh	WG747D Signal	59.930	Coalcliff	358B Points	Y	Y	Y	N	Y	N	Y	Y	T	N	S	S
10114	Illawarra, Single Line	59.930	Coalcliff	358B Points	61.820	Clifton	351 Points	Y	Y	Y	N	Y	N	Y	Y	T	N	S	S
10115	Illawarra, Main Down	61.820	Clifton	351 Points	84.370	Coniston	204 Points	Y	Y	Y	N	Y	N	Y	Y	T	N	S	S
10116	Illawarra, Single Line	84.370	Coniston	204B Points	85.320	Unanderra North Jct	1103A Points	Y	Y	Y	N	Y	N	Y	Y	T	N	S	N
10117	Illawarra, Main Down	85.320	Unanderra North Jct	1103 Points	87.840	Unanderra	1105B Points	Y	P	Y	N	Y	N	Y	Y	T	N	S	N
10118	Illawarra, Single Line	87.840	Unanderra	1105B Points	119.160	Kiama	Platform	Y	P	Y	N	Y	N	Y	Y	T	N	S	N
10118	Illawarra, Single Line	119.160	Kiama	Platform	153.630	Bomaderry	Dead end	Y	P	N	Y	N	Y	N	N	N	N	N	N
10119	Illawarra, Main Up	0.500	Central	632 Points start of Illa Up	6.600	Tempe	750B Points	Y	N	Y	N	Y	N	Y	Y	Y	R	N	N

Authorised Rolling Stock Outlines on Track Sections

Legend

Y	The Outline is authorised to operate, and shall be considered when designing or maintaining the Infrastructure.	S	The Outline is authorised for single line working only. It does not need to be considered when designing or maintaining track centres but it shall be considered when designing or maintaining all other Infrastructure.
P	The Outline is not currently authorised, but is planned to be authorised, and shall be considered when designing or maintaining the Infrastructure.	T	The Outline is authorised under restricted operating conditions. It does not need to be considered when designing or maintaining any Infrastructure or track centres.
R	The Outline is authorised but has restricted operating conditions through platforms. It does not need to be considered when designing or maintaining platforms but it shall be considered when designing or maintaining other Infrastructure.	N	The Outline is not authorised , and does not need to be considered when designing or maintaining the Infrastructure.

Base Code	Track Name	From			To			Rolling stock outlines											
		km	Track Location	Location Description	km	Track Location	Location Description	Narrow Non-Electric	Narrow Square	Narrow Container	Intersystem	Narrow Hopper	Double Stack	Narrow Electric	Medium Electric	Extended Medium	Wide Electric	Out of Gauge Load	NZZA Wagon
10119	Illawarra, Main Up	6.600	Tempe	750B Points	46.535	Helensburgh	WG749U Signal	Y	Y	Y	N	Y	N	Y	Y	Y	R	S	S
10119	Illawarra, Main Up	46.535	Helensburgh	WG749U Signal	59.930	Coalcliff	358 Points	Y	Y	Y	N	Y	N	Y	Y	T	N	S	S
10120	Illawarra, Main Up	61.820	Clifton	351 Points	84.370	Coniston	204B Points	Y	Y	Y	N	Y	N	Y	Y	T	N	S	S
10121	Illawarra, Main Up	84.320	Unanderra North Jct	1103A Points	87.840	Unanderra	1105Points	Y	Y	Y	N	Y	N	Y	Y	T	N	S	N
10122	Port Kembla, Down	84.310	Coniston	204A Points	88.640	Port Kembla Nth	186 Points	Y	Y	N	N	Y	N	Y	Y	T	N	S	N
10123	Port Kembla, Up	84.380	Coniston	203 Points	88.640	Port Kembla Nth	186 Points	Y	Y	N	N	Y	N	Y	Y	T	N	S	N
10124	Eastern Suburbs, Down	0.000	Central	0km Platform 24	6.880	Bondi Jct	909A Points	Y	N	Y	N	Y	N	Y	Y	Y	R	N	N
10125	Eastern Suburbs, Up	0.000	Central	0km Platform 25	7.010	Bondi Jct	909B Points	Y	N	Y	N	Y	N	Y	Y	Y	R	N	N
10126	Illawarra, Relief Down	0.000	Central	0km Platform 25	2.780	Erskineville	680 Points	Y	N	Y	N	Y	N	Y	Y	Y	R	N	N
10127	Illawarra, Relief Up	0.000	Central	0km Platform 24	2.780	Erskineville	679 Points	Y	N	Y	N	Y	N	Y	Y	Y	R	N	N
10128	Inner Harbour Branch, Down	84.210	Coniston	206 Points	84.335	Inner Harbour	RailCorp boundary	Y	N	N	N	Y	N	Y	N	N	N	S	N
10129	Inner Harbour Branch, Up	84.210	Coniston	205 Points	84.335	Inner Harbour	RailCorp boundary	Y	N	N	N	Y	N	Y	N	N	N	S	N
10130	Port Kembla, Single Line	88.640	Port Kembla Nth	186 Points	90.390	Port Kembla	Dead End	Y	Y	N	N	Y	N	Y	Y	T	N	S	N
10131	Wongawilli Colliery, Single Line	93.550	Wongawilli Colliery Jct	Points to Wongawilli Colliery	93.650	Wongawilli Colliery	Dead End	Y	N	N	N	Y	N	N	N	N	N	N	N
10132	Metropolitan Colliery, Single Line	48.920	Metropolitan Colliery Jct	387B Points	50.000	Metropolitan Colliery	Dead End	Y	N	N	N	Y	N	N	N	N	N	N	N
10138	South Fork Flyover, Up	84.570	Port Kembla Inner Harbour	208 Points	85.770	Unanderra North	1101 Points	Y	N	N	N	Y	N	N	N	N	N	S	N
10139	South Fork Flyover, Down	84.640	Port Kembla Inner Harbour	211 Points	85.860	Unanderra North	1103B Points	Y	N	Y	N	Y	N	Y	N	N	N	S	N
10140	Illawarra, Dive Down	1.430	Redfern	649 Points	2.360	Illawarra Jct	674 Points	Y	N	Y	N	Y	N	Y	Y	Y	R	N	N
10141	Illawarra, Dive Up	1.370	Redfern	648 Points	2.380	Illawarra Jct	675 Points	Y	N	Y	N	Y	N	Y	Y	Y	R	N	N
10149	Pymont Branch, Single Line	13.370	Balmain Rd Jct	27 Points	20.000	Regent St Jct	257 Points	Y	N	N	N	Y	N	N	N	N	N	S	N
10150	Chullora Jct to Sefton Park Jct Down	17.083	Chullora Jct	346 Points	19.913	Chullora Jct	373B Points	Y	Y	Y	Y	Y	N	Y	Y	Y	R	S	S
10151	Chullora Jct to Sefton Park Jct Up	17.084	Chullora Jct	347 Points	21.653	Sefton East Jct	202 Points	Y	Y	Y	Y	Y	N	Y	Y	Y	R	S	S
10152	Clyde to Carlingford, Down	20.750	Clyde	40 Points	22.160	Rosehill	1034 Points	Y	N	Y	N	Y	N	Y	Y	Y	R	N	N

Authorised Rolling Stock Outlines on Track Sections

Legend

Y	The Outline is authorised to operate, and shall be considered when designing or maintaining the Infrastructure.	S	The Outline is authorised for single line working only. It does not need to be considered when designing or maintaining track centres but it shall be considered when designing or maintaining all other Infrastructure.
P	The Outline is not currently authorised, but is planned to be authorised, and shall be considered when designing or maintaining the Infrastructure.	T	The Outline is authorised under restricted operating conditions. It does not need to be considered when designing or maintaining any Infrastructure or track centres.
R	The Outline is authorised but has restricted operating conditions through platforms. It does not need to be considered when designing or maintaining platforms but it shall be considered when designing or maintaining other Infrastructure.	N	The Outline is not authorised , and does not need to be considered when designing or maintaining the Infrastructure.

Base Code	Track Name	From			To			Rolling stock outlines											
		km	Track Location	Location Description	km	Track Location	Location Description	Narrow Non-Electric	Narrow Square	Narrow Container	Intersystem	Narrow Hopper	Double Stack	Narrow Electric	Medium Electric	Extended Medium	Wide Electric	Out of Gauge Load	NZZA Wagon
10153	Clyde to Carlingford, Up	20.750	Clyde	41 Points	22.160	Rosehill	1034 Points	Y	N	Y	N	Y	N	Y	Y	Y	R	N	N
10154	Clyde to Carlingford, Single Line	22.160	Rosehill	1034 Points	28.060	Carlingford	Dead end	Y	N	Y	N	Y	N	Y	Y	Y	R	N	N
10155	Rosehill to Sandown, Single Line	22.300	Rosehill	1035 Points	24.160	Sandown	Stop Block	Y	N	Y	N	Y	N	Y	Y	Y	R	N	N
10156	Olympic Park Balloon Loop	15.839	Flemington North Jct	861 Points	19.267	Flemington North Jct	862 Points	Y	N	Y	N	Y	N	Y	Y	Y	N	N	N
10157 Note 2	North Strathfield Goods, Single Line	12.700	North Strathfield	557B Points	14.790	Flemington East Jct	641 Points Slip	Y	Y	Y	Y	Y	N	Y	Y	Y	R	S	S
10158 Note 2	Flemington Goods, Down	14.620	Flemington	634 Points	16.080	Flemington West Jct	697 Points	Y	Y	Y	Y	Y	N	Y	Y	Y	R	S	S
10159 Note 2	Flemington Goods, Up	14.600	Flemington	635 Points	16.080	Flemington West Jct	696 Points	Y	Y	Y	Y	Y	N	Y	Y	Y	R	S	S
10160 Note 2	West Fork, Down	15.440	Flemington Middle Jct	687 Points	15.830		Points end Olympic loop	Y	N	Y	N	Y	N	Y	Y	Y	N	N	N
10161 Note 2	West Fork, Up	15.440	Flemington Middle Jct	686 Points	15.860		Points start Olympic loop	Y	N	Y	N	Y	N	Y	Y	Y	N	N	N
10168 Note 2	Metropolitan Goods, East Through Road	14.380	Enfield South	302 Points	16.500	Enfield North	399 Points	Y	Y	Y	Y	Y	N	Y	Y	Y	Y	S	S
10169	City Circle, City Inner	0.000	Central	0km Platform 20	5.850	Central	0km Platform 19	Y	N	Y	N	Y	N	Y	Y	Y	R	N	N
10170	City Circle, City Outer	0.000	Central	0km Platform 17	5.890	Central	0km Platform 22	Y	N	Y	N	Y	N	Y	Y	Y	R	N	N
10171	Hamilton Dn Loop & Newcastle Up Main	163.786	Woodville Jct	42S Points	168.220	Newcastle	Dead End Platform 2	Y	N	Y	N	Y	N	Y	Y	N	N	N	N
10172	Hamilton Dn Loop & Newcastle Up Main	163.786	Woodville Jct	42S Points	168.22	Newcastle	Dead End Platform 2	Y	N	Y	N	Y	N	Y	Y	N	N	N	N
10173	Hamilton Up Loop & Newcastle Dn Main	163.71	Woodville Jct	Points 41S	168.22	Newcastle	Dead End Platform 1	Y	N	Y	N	Y	N	Y	Y	N	N	N	N
10174	Hamilton Jct to Islington Jct Main Down	163.781	Hamilton	Points 19	164.409	Islington Jct	106 Points	Y	N	Y	N	Y	N	Y	Y	N	N	N	N
10175	Broadmeadow via Relief Down	161.21	Broadmeadow Yard	406 Points	164.457	Islington Jct	105 Points	Y	Y	Y	N	Y	N	N	N	N	N	N	N
10176	Unanderra North Jct to Allens Creek,	84.743	Unanderra North Jct	1102 Points to Triangle	86.382	Lysaghts Platform	197B Points	Y	Y	N	N	Y	N	N	N	N	N	S	N

Authorised Rolling Stock Outlines on Track Sections

Legend

Y	The Outline is authorised to operate, and shall be considered when designing or maintaining the Infrastructure.	S	The Outline is authorised for single line working only. It does not need to be considered when designing or maintaining track centres but it shall be considered when designing or maintaining all other Infrastructure.
P	The Outline is not currently authorised, but is planned to be authorised, and shall be considered when designing or maintaining the Infrastructure.	T	The Outline is authorised under restricted operating conditions. It does not need to be considered when designing or maintaining any Infrastructure or track centres.
R	The Outline is authorised but has restricted operating conditions through platforms. It does not need to be considered when designing or maintaining platforms but it shall be considered when designing or maintaining other Infrastructure.	N	The Outline is not authorised , and does not need to be considered when designing or maintaining the Infrastructure.

Base Code	Track Name	From			To			Rolling stock outlines											
		km	Track Location	Location Description	km	Track Location	Location Description	Narrow Non-Electric	Narrow Square	Narrow Container	Intersystem	Narrow Hopper	Double Stack	Narrow Electric	Medium Electric	Extended Medium	Wide Electric	Out of Gauge Load	NZZA Wagon
	Triangle Loop																		
10177	Main West, Down	21.550	Granville	710 Points	58.828	Emu Plains	Signal No 35.9	Y	Y	Y	N	Y	N	Y	Y	Y	R	S	S
10177	Main West, Down	58.828	Emu Plains	Signal No 35.9	80.388	Springwood	118B Points	Y	P	Y	N	Y	N	Y	Y	N	N	S	S
10177	Main West, Down	80.388	Springwood	118B Points	145.240	Edgecombe	7A Points	Y	P	Y	N	Y	N	Y	N	N	N	S	S
10177	Main West, Down	145.240	Edgecombe	7A Points	150.630	Zig Zag	8B Points	Y	P	Y	N	Y	N	Y	N	N	N	N	N
10177	Main West, Down	150.630	Zig Zag	8B Points	156.361	Lithgow	Signal 97.1	Y	P	Y	N	Y	N	Y	N	N	N	S	S
10177	Main West, Down	156.361	Lithgow	Signal 97.1	158.800	Bowenfels	CRN boundary	Y	P	Y	N	Y	N	N	N	N	N	S	S
10178	Main West, Up	21.470	Granville	709 Points	58.828	Emu Plains	Signal No 35.9	Y	Y	Y	N	Y	N	Y	Y	Y	R	S	S
10178	Main West, Up	58.828	Emu Plains	Signal No 35.9	80.388	Springwood	118A Points	Y	Y	Y	N	Y	N	Y	Y	N	N	S	S
10178	Main West, Up	80.388	Springwood	118A Points	156.361	Lithgow	Signal 97.1	Y	Y	Y	N	Y	N	Y	N	N	N	S	S
10177	Main West, Up	156.361	Lithgow	Signal 97.1	158.800	Bowenfels	CRN boundary	Y	P	Y	N	Y	N	Y	N	N	N	S	S
10188	Main West, Branch Down	32.270	Seven Hills	301 Points	34.602	Blacktown	313 Points	Y	N	Y	N	Y	N	Y	Y	Y	R	N	N
10189	Blacktown to Richmond, Branch Down	34.600	Blacktown	313 Points	43.333	Schofields	53 Points	Y	N	Y	N	Y	N	Y	Y	Y	R	N	N
10190	Blacktown to Richmond, Branch Up	34.664	Blacktown	313 Points	43.333	Schofields	53 Points	Y	N	Y	N	Y	N	Y	Y	Y	R	N	N
10191	Blacktown to Richmond, Single Line	43.333	Schofields	53 Points	60.761	Richmond	Dead end	Y	N	Y	N	Y	N	Y	Y	Y	R	N	N
10192 Note 2	Sefton Park Jct East Fork, Fork Down	22.750	Sefton Park Jct East Jct	42 Points	23.200	Sefton Park North Jct	22 Points	Y	Y	Y	Y	Y	N	Y	Y	Y	R	S	S
10193 Note 2	Sefton Park Jct East Fork, Fork Up	22.750	Sefton Park Jct East Jct	Points Ball Lever	23.200	Sefton Park North Jct	21 Points	Y	Y	Y	Y	Y	N	Y	Y	Y	R	S	S
10194 Note 2	Chullora Jct North Fork, Down	17.590	Chullora Jct North Jct	431 Points	17.950	Chullora Jct West Jct	410 Points	Y	Y	Y	Y	Y	N	Y	Y	Y	R	S	S
10195 Note 2	Chullora Jct North Fork, Up	17.590	Chullora Jct North Jct	348 Points	17.950	Chullora Jct West Jct	351 Points	Y	Y	Y	Y	Y	N	Y	Y	Y	R	S	S
10196	Chullora Branch, Single Line	17.470	Chullora Jct West Jct	353 Points	20.210	Elcar Chullora	Points at Lever EW	Y	Y	Y	N	Y	N	Y	Y	Y	R	S	S
10197	Vales Point, Balloon Loop	119.230	Vales Point	22 Points	121.710	Vales Point	21 Points	Y	N	N	N	Y	N	N	N	N	N	S	S

Authorised Rolling Stock Outlines on Track Sections

Legend

Y	The Outline is authorised to operate, and shall be considered when designing or maintaining the Infrastructure.	S	The Outline is authorised for single line working only. It does not need to be considered when designing or maintaining track centres but it shall be considered when designing or maintaining all other Infrastructure.
P	The Outline is not currently authorised, but is planned to be authorised, and shall be considered when designing or maintaining the Infrastructure.	T	The Outline is authorised under restricted operating conditions. It does not need to be considered when designing or maintaining any Infrastructure or track centres.
R	The Outline is authorised but has restricted operating conditions through platforms. It does not need to be considered when designing or maintaining platforms but it shall be considered when designing or maintaining other Infrastructure.	N	The Outline is not authorised , and does not need to be considered when designing or maintaining the Infrastructure.

Base Code	Track Name	From			To			Rolling stock outlines											
		km	Track Location	Location Description	km	Track Location	Location Description	Narrow Non-Electric	Narrow Square	Narrow Container	Intersystem	Narrow Hopper	Double Stack	Narrow Electric	Medium Electric	Extended Medium	Wide Electric	Out of Gauge Load	NZZA Wagon
10198	Eraring, Balloon Loop	132.550	Eraring	52 Points	134.440	Eraring	51 Points	Y	N	N	N	Y	N	N	N	N	N	S	S
10199	Newstan, Balloon Loop	142.960	Fassifern	7 Points	144.800	Newstan Balloon Loop	Points?	Y	N	N	N	Y	N	N	N	N	N	N	N
10200	Teralba Colliery, Balloon Loop	150.290	Cockle Creek	111 Points	153.320	Cockle Creek	110 Points	Y	N	N	N	Y	N	N	N	N	N	N	N
10227	Clarence Colliery Balloon Loop, Balloon Loop	141.760	Newnes Jct	Points Up Main to Loop	143.000	Clarence Colliery Loop	Points	Y	N	N	N	Y	N	N	N	N	N	N	N
10232	Main North, Relief Down	12.500	Strathfield	553A Points	16.780	Rhodes	53 Points	Y	Y	Y	Y	Y	N	Y	Y	Y	R	S	S
10233	Main North, Relief Up	12.540	North Strathfield	566 Points	14.450	Concord West	578 Points	Y	Y	Y	Y	Y	N	Y	Y	Y	R	S	S
10235	Lidcombe Western Loop, Loop Triangle	17.200	Lidcombe	717 Points	18.000	Lidcombe	718 Points	Y	Y	Y	Y	Y	N	Y	Y	Y	R	S	S
10236	Meeks Rd North Fork, Down	5.500	Meeks Road Jct	760 Points	6.200	Meeks Road Jct	774 Points West Jct	Y	Y	Y	Y	Y	N	N	N	N	N	S	S
10237	Meeks Rd North Fork, Up	5.500	Meeks Road Jct	761 Points	6.200	Meeks Road Jct	773 Points West Jct	Y	Y	Y	Y	Y	N	Y	N	N	N	S	S
10238	Meeks Rd East Fork, Down	6.000	Meeks Road North Jct	763 Points	6.500	Meeks Rd South Jct	765 Points	Y	N	N	N	Y	N	N	N	N	N	S	S
10239	Meeks Rd East Fork, Up	6.000	Meeks Road North Jct	764 Points	6.500	Meeks Rd South Jct	766 Points	Y	N	N	N	Y	N	N	N	N	N	S	S
10240	Main North, Relief Down	28.600	Pennant Hills	50 Points	29.350	Thornleigh	52 Points	Y	Y	Y	Y	Y	N	Y	Y	Y	R	S	S
10241	Main North, Relief Up	28.660	Pennant Hills	51 Points	30.000	Thornleigh	55 Points	Y	Y	Y	Y	Y	N	Y	Y	Y	R	S	S
10243	Enfield Fork Down, Loop Triangle	19.810	Flemington South Jct	693Points	20.150	Flemington Middle Jct	689 Points	Y	Y	Y	Y	Y	N	Y	Y	Y	R	S	S
10244	Enfield Fork Up, Loop Triangle	19.810	Flemington South Jct	694 Points	20.150	Flemington Middle Jct	688 Points	Y	Y	Y	Y	Y	N	Y	Y	Y	R	S	S
10246	Enfield South to Enfield North via DELEC, Single Line	13.780	Enfield South	Points? to Loco Dep Rd	16.760	Enfield North	402 Points	Y	N	Y	N	Y	N	Y	N	N	N	S	S
10247	Main North, Relief Up	161.400	Adamstown	410 Points	163.750	Woodville Jct	39B Points	Y	Y	Y	Y	Y	N	Y	Y	N	N	S	S
10251	Homebush Bay East Fork Down	14.568	Flemington	635 Points	15.839	Flemington North	Points 861	Y	N	Y	N	Y	N	Y	Y	Y	N	N	N

Authorised Rolling Stock Outlines on Track Sections

Legend

Y	The Outline is authorised to operate, and shall be considered when designing or maintaining the Infrastructure.	S	The Outline is authorised for single line working only. It does not need to be considered when designing or maintaining track centres but it shall be considered when designing or maintaining all other Infrastructure.
P	The Outline is not currently authorised, but is planned to be authorised, and shall be considered when designing or maintaining the Infrastructure.	T	The Outline is authorised under restricted operating conditions. It does not need to be considered when designing or maintaining any Infrastructure or track centres.
R	The Outline is authorised but has restricted operating conditions through platforms. It does not need to be considered when designing or maintaining platforms but it shall be considered when designing or maintaining other Infrastructure.	N	The Outline is not authorised , and does not need to be considered when designing or maintaining the Infrastructure.

Base Code	Track Name	From			To			Rolling stock outlines											
		km	Track Location	Location Description	km	Track Location	Location Description	Narrow Non-Electric	Narrow Square	Narrow Container	Intersystem	Narrow Hopper	Double Stack	Narrow Electric	Medium Electric	Extended Medium	Wide Electric	Out of Gauge Load	NZZA Wagon
						Jct													
10252	Homebush Bay East Fork Up	14.547	Flemington	634 Points	15.86	Flemington North Jct	Points 862	Y	N	Y	N	Y	N	Y	Y	Y	N	N	N
10553	Airport Line Down	0.000	Central	0km Platform 23	9.993	Turrella	500B Points	Y	N	Y	N	Y	N	Y	Y	Y	R	N	N
10554	Airport Line Up	0.000	Central	0km Platform 21	9.908	Turrella	500A Points	Y	N	Y	N	Y	N	Y	Y	Y	R	N	N
11374	Lavender Bay No1 Car Sdg and Branch Down	5.99	Waverton	600B Points	8.1	North Sydney Lavender Bay Car Sdg	Dead End No1 Car Sdg	Y	N	N	N	N	N	Y	Y	Y	N	N	N
11428	Richmond Branch Up	32.78	Seven Hills	309 Points	34.667	Blacktown	313B Points	Y	N	Y	N	Y	N	Y	Y	Y	R	N	N
11491	Glenfield Ingleburn Up Relief	40.701	Glenfield North Jct	39A Points	46.439	Ingleburn	61B Points	Y	Y	Y	Y	Y	N	Y	Y	Y	R	S	S
12766	Hornsby Down Relief	32.823	Hornsby Yard	500A Points	35.377	Hornsby Yard	574B Points	Y	Y	Y	Y	Y	N	Y	Y	Y	R	S	S
12797	East Hills Main Down	7.242	Wolli Creek Jct	753 Points	14.235	Beverly Hills	511B Points	Y	N	Y	N	Y	N	Y	Y	Y	R	N	N
12798	East Hills Main Up	7.242	Wolli Creek Jct	754 Points	14.235	Beverly Hills	511B Points	Y	N	Y	N	Y	N	Y	Y	Y	R	N	N
12814	Chatswood - Epping Down Main	11.294	Chatswood	84A Points	25.632	Epping	112 Points	Y	N	Y	N	Y	N	Y	Y	Y	R	N	N
12815	Chatswood - Epping Up Main	11.303	Chatswood	86A Points	25.606	Epping	111 Points	Y	N	Y	N	Y	N	Y	Y	Y	R	N	N
12981	Sutherland to Cronulla, Down Main	24.396	Sutherland	151A Points	34.767	Cronulla	Sutherland to Cronulla Dn Main Dead End	Y	N	Y	N	Y	N	Y	Y	Y	R	N	N
12982	Sutherland to Cronulla, Up Main	24.885	Sutherland	159A Points	34.980	Cronulla	Dead End	Y	N	Y	N	Y	N	Y	Y	Y	R	N	N

Note 1: The table may include lines that are not currently in service and private sidings. The table provides the applicable outlines should design or maintenance be required but noting that the requirements of the private siding owner/ leaseholder would take precedence for maintenance/ renewal

Note 2: Some out of date basecode definitions have been continued as these still define the boundaries for approved outlines. In this case the basecode is shown in *grey italics*.

Appendix B Rolling Stock Cross-Sections

"Narrow Non-Electric" Rollingstock Outline Dimensions

Bogie Centres: 16155 mm
Body Overhang: 3353 mm

Coordinates

Point	Lateral	Vertical
A	0	75
B	940	75
C	940	152
D	1220	152
E	1450	345
F	1450	1120
G	1485	1120
H	1485	3580
I	1250	3916
J	1065	4040
K	760	4190
L	455	4270
M	0	4270

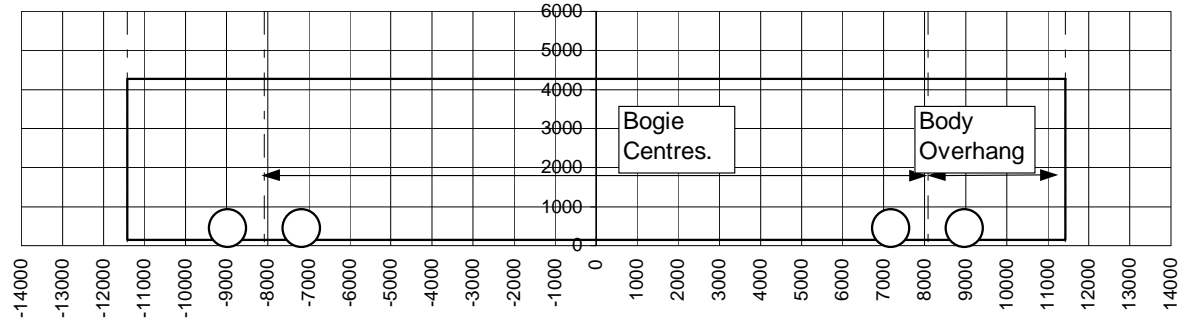
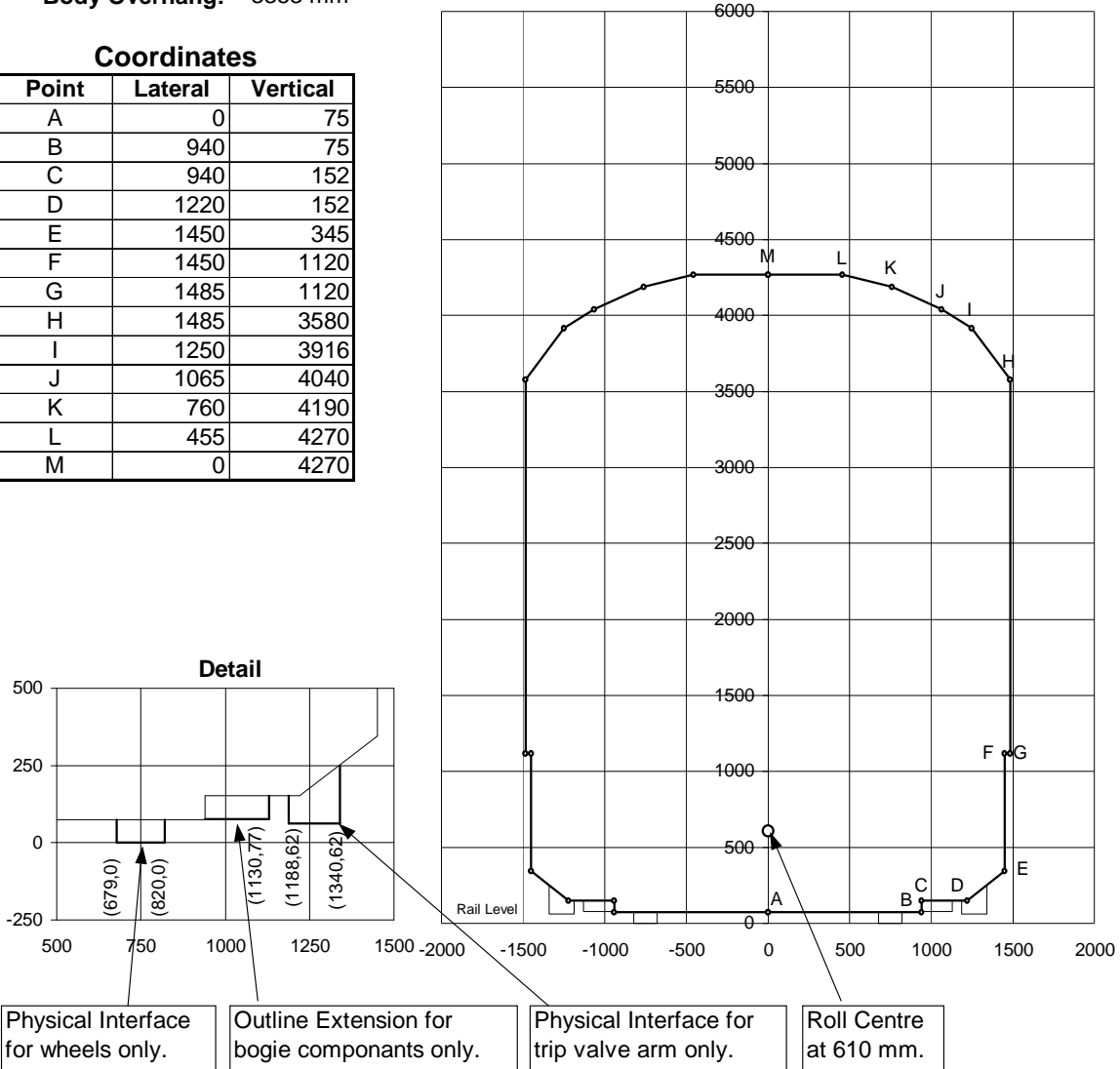

- All cross-section dimensions are symmetrical about the vehicle centreline.
- The origin for all horizontal coordinates is the vehicle centreline.
- The origin for all cross-section vertical coordinates is the rail level.
- The origin for all pantograph vertical coordinates is the contact position with fully worn contact brushes.
- All dimensions are in millimetres.

Figure 8 - Narrow Non-Electric rolling stock outline dimensions

"Narrow Square" Rollingstock Outline Dimensions

Bogie Centres: 16155 mm
Body Overhang: 3353 mm

Coordinates

Point	Lateral	Vertical
A	0	75
B	940	75
C	940	152
D	1450	152
E	1450	1120
F	1485	1120
G	1485	3580
H	1250	3916
I	1065	4040
J	760	4190
K	455	4270
L	0	4270

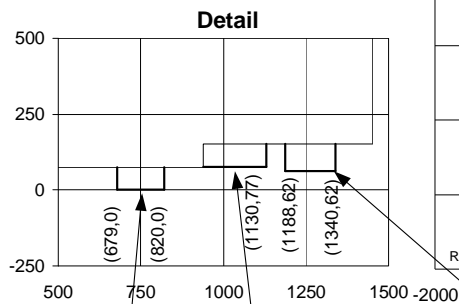
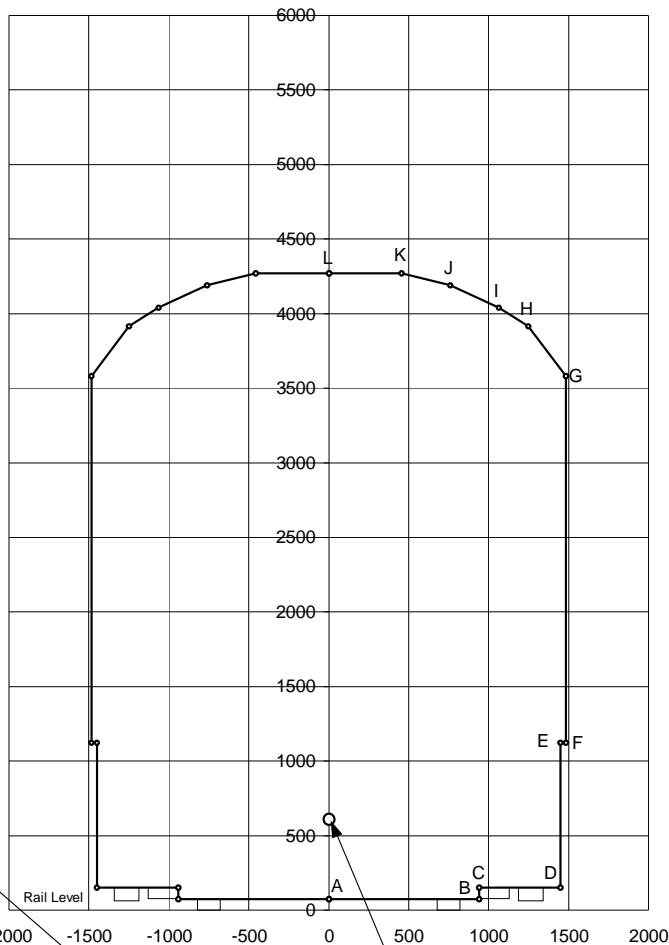

Physical Interface for wheels only.

Outline Extension for bogie components only.

Physical Interface for trip valve arm only.

Roll Centre at 610 mm.

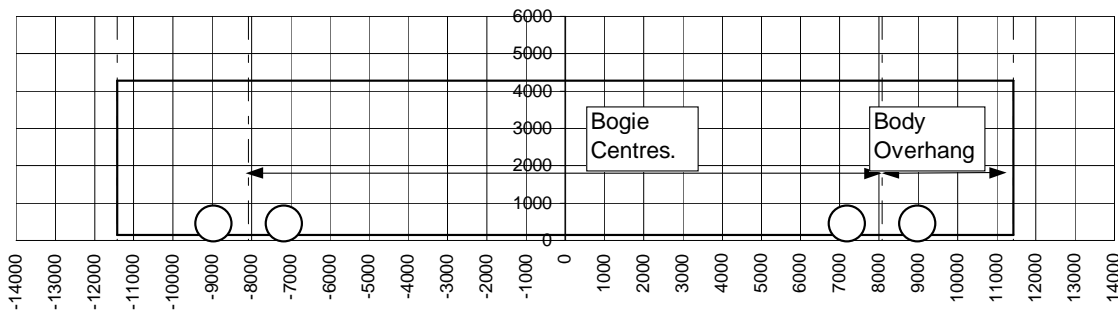

- All cross-section dimensions are symmetrical about the vehicle centreline.
- The origin for all horizontal coordinates is the vehicle centreline.
- The origin for all cross-section vertical coordinates is the rail level.
- The origin for all pantograph vertical coordinates is the contact position with fully worn contact brushes.
- All dimensions are in millimetres.

Figure 9 - Narrow Square rolling stock outline dimensions

"Narrow Container" Rollingstock Outline Dimensions

Bogie Centres: 17300 mm
Body Overhang: 3603 mm

Coordinates

Point	Lateral	Vertical
A	0	75
B	890	75
C	890	152
D	1170	152
E	1400	345
F	1400	1120
G	1435	1120
H	1435	3580
I	1250	4030
J	710	4190
K	405	4270
L	0	4270

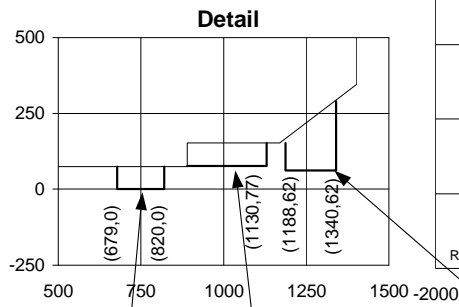
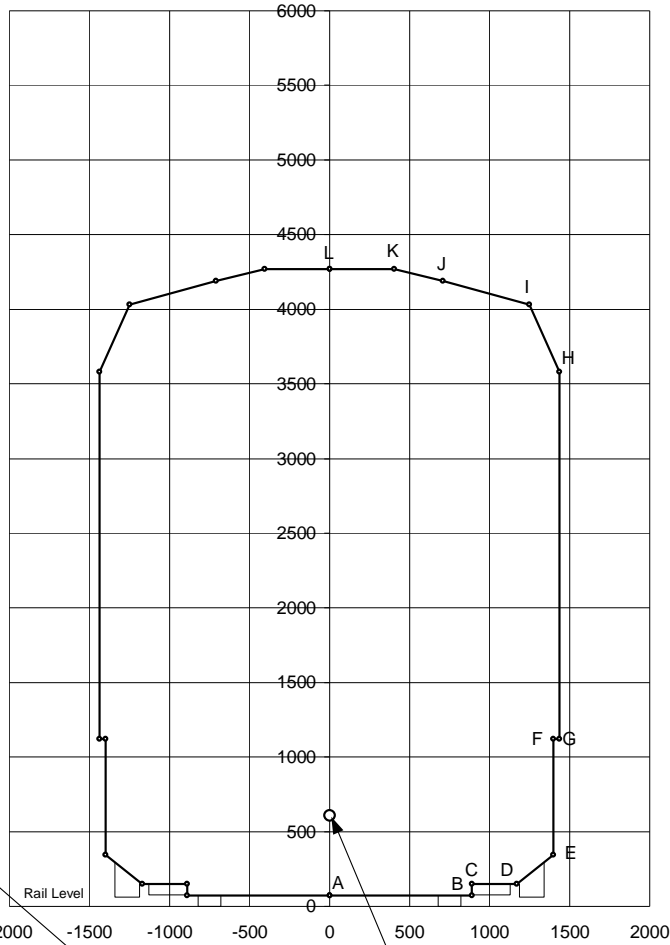

Physical Interface for wheels only.

Outline Extension for bogie components only.

Physical Interface for trip valve arm only.

Roll Centre at 610 mm.

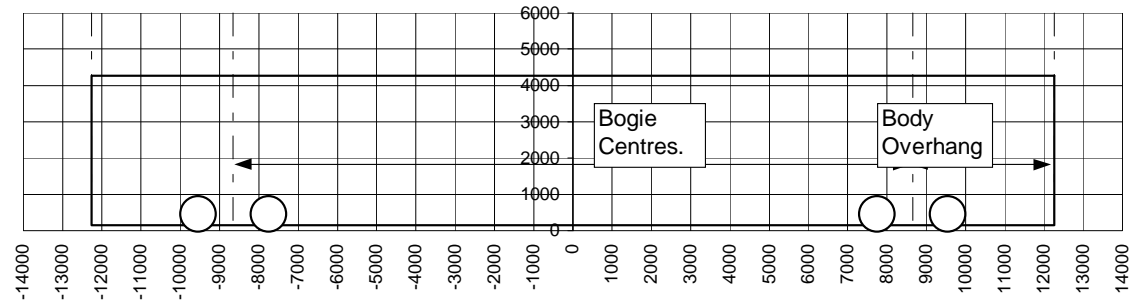

- All cross-section dimensions are symmetrical about the vehicle centreline.
- The origin for all horizontal coordinates is the vehicle centreline.
- The origin for all cross-section vertical coordinates is the rail level.
- The origin for all pantograph vertical coordinates is the contact position with fully worn contact brushes.
- All dimensions are in millimetres.

Figure 10 - Narrow Container rolling stock outline dimensions

"Intersystem" Rollingstock Outline Dimensions

Bogie Centres: 16155 mm
Body Overhang: 3353 mm

Coordinates

Point	Lateral	Vertical
A	0	75
B	940	75
C	940	152
D	1450	152
E	1450	1120
F	1485	1120
G	1485	3580
H	1250	4030
I	760	4190
J	455	4270
K	0	4270

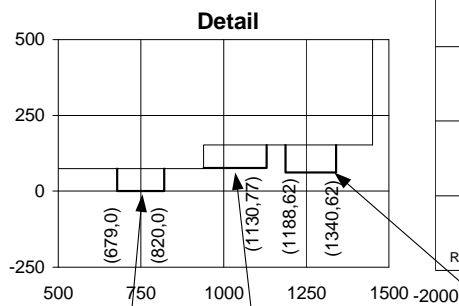
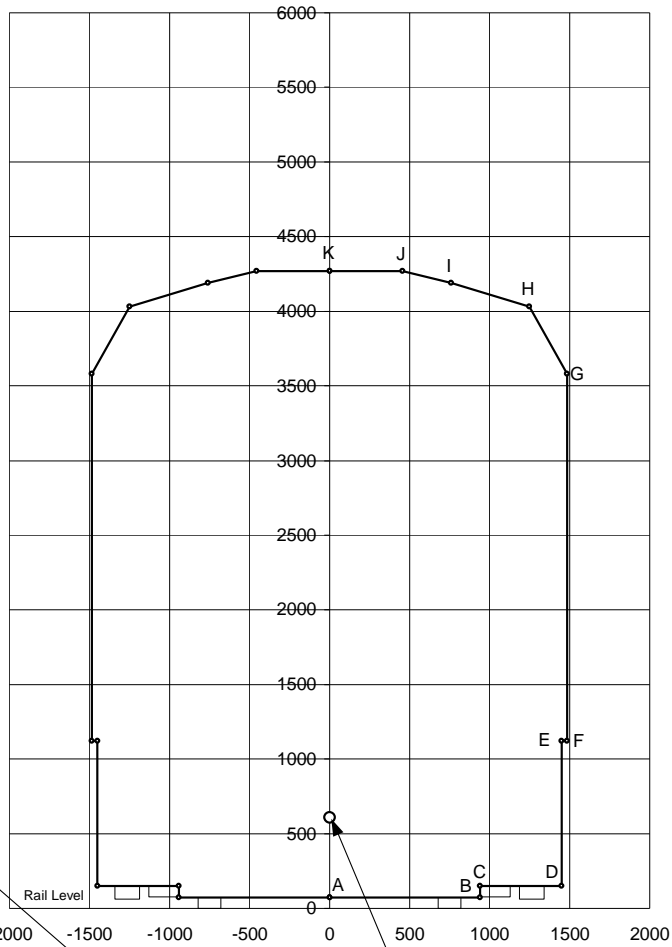

Physical Interface for wheels only.

Outline Extension for bogie components only.

Physical Interface for trip valve arm only.

Roll Centre at 610 mm.

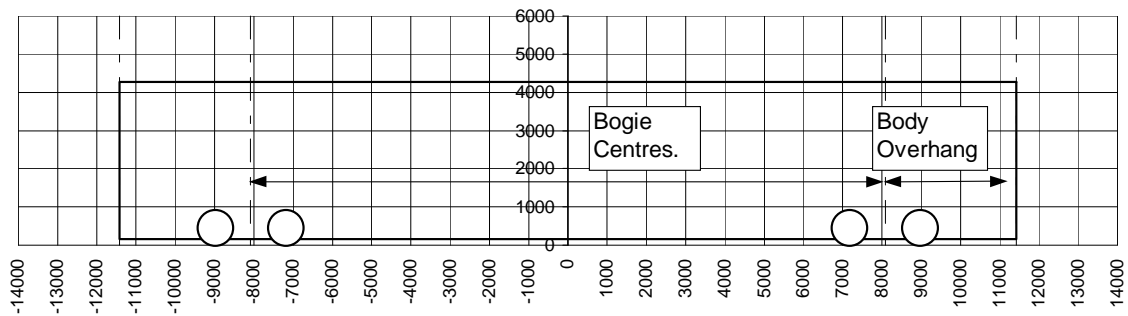

- All cross-section dimensions are symmetrical about the vehicle centreline.
- The origin for all horizontal coordinates is the vehicle centreline.
- The origin for all cross-section vertical coordinates is the rail level.
- The origin for all pantograph vertical coordinates is the contact position with fully worn contact brushes.
- All dimensions are in millimetres.

Figure 11 - Intersystem rolling stock outline dimensions

"Narrow Hopper" Rollingstock Outline Dimensions

Bogie Centres: 13000 mm
Body Overhang: 1500 mm

Coordinates

Point	Lateral	Vertical
A	0	75
B	940	75
C	940	152
D	1220	152
E	1450	345
F	1450	1120
G	1485	1120
H	1485	1800
I	1510	2075
J	1525	2350
K	1510	2625
L	1485	2900
M	1485	3580
N	1250	3916
O	1065	4040
P	760	4190
Q	455	4270
R	0	4270

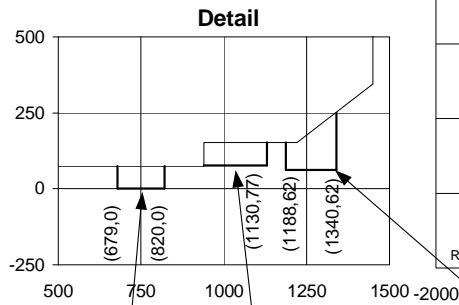
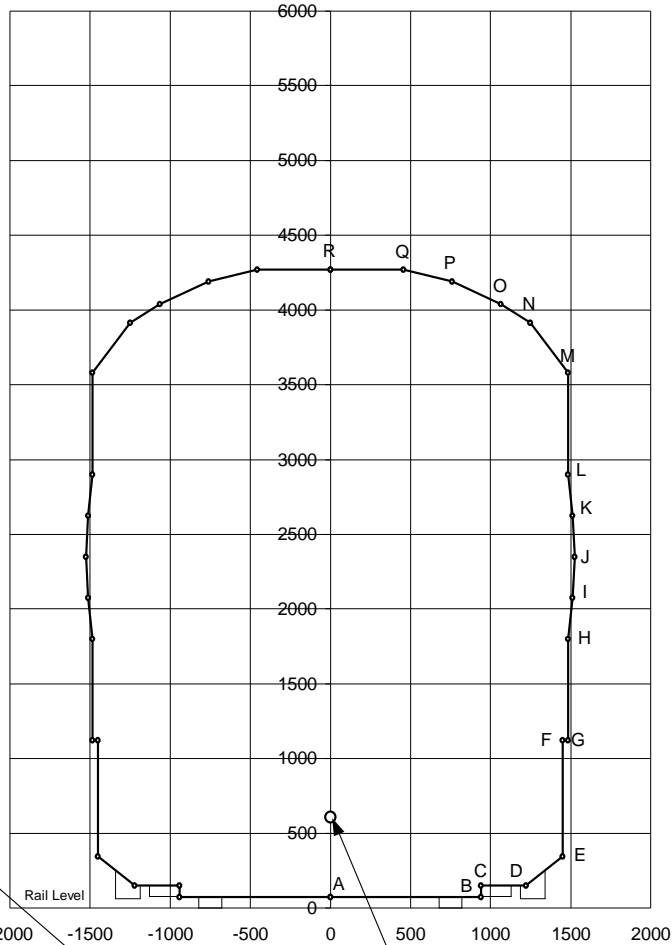

Physical Interface for wheels only.

Outline Extension for bogie components only.

Physical Interface for trip valve arm only.

Roll Centre at 610 mm.

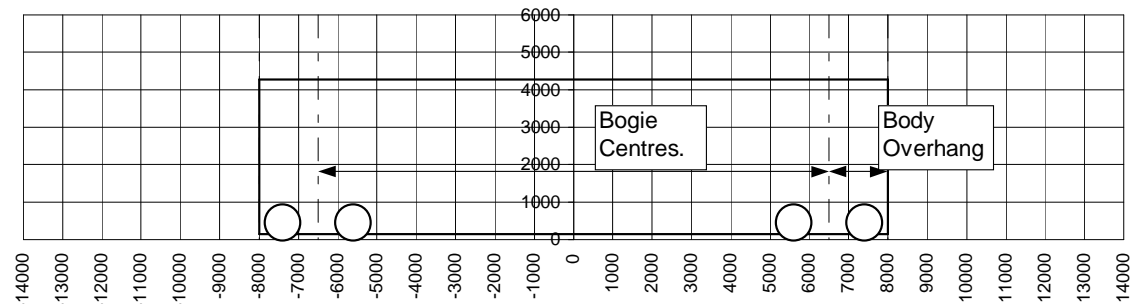

- All cross-section dimensions are symmetrical about the vehicle centreline.
- The origin for all horizontal coordinates is the vehicle centreline.
- The origin for all cross-section vertical coordinates is the rail level.
- The origin for all pantograph vertical coordinates is the contact position with fully worn contact brushes.
- All dimensions are in millimetres.

Figure 12 - Narrow Hopper rolling stock outline dimensions

"Double Stack" Rollingstock Outline Dimensions

Bogie Centres: 17300 mm
Body Overhang: 3603 mm

Coordinates

Point	Lateral	Vertical
A	0	75
B	890	75
C	890	152
D	1170	152
E	1400	345
F	1400	1120
G	1435	1120
H	1435	3580
I	1250	5520
J	1250	5850
K	0	5850

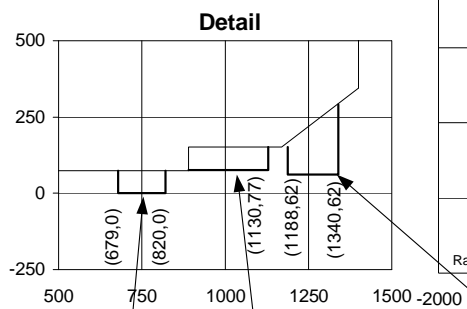
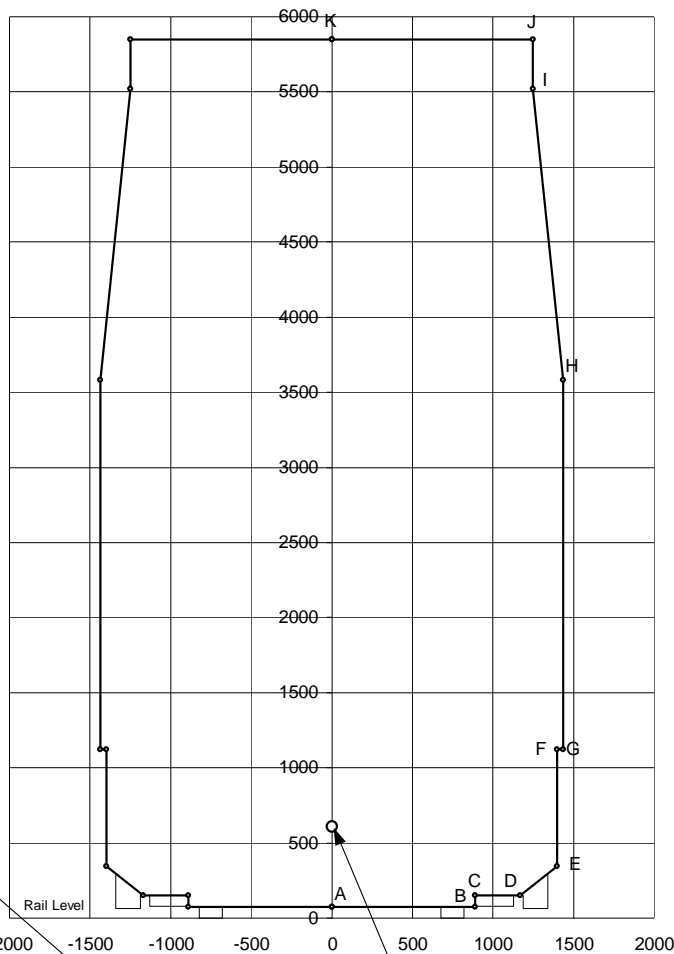

Physical Interface for wheels only.

Outline Extension for bogie components only.

Physical Interface for trip valve arm only.

Roll Centre at 610 mm.

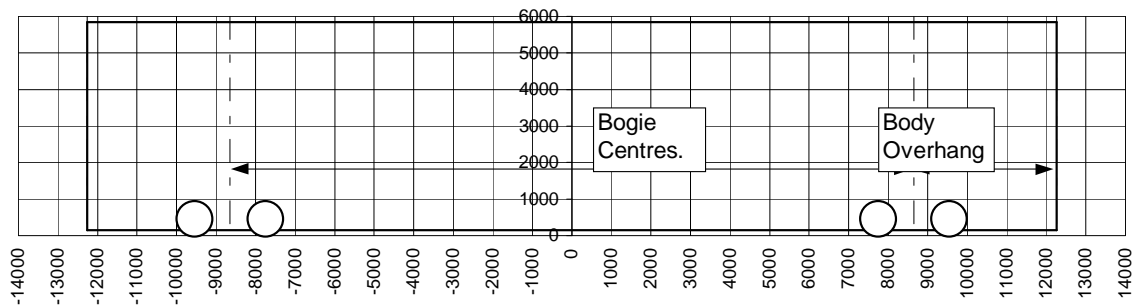

- All cross-section dimensions are symmetrical about the vehicle centreline.
- The origin for all horizontal coordinates is the vehicle centreline.
- The origin for all cross-section vertical coordinates is the rail level.
- The origin for all pantograph vertical coordinates is the contact position with fully worn contact brushes.
- All dimensions are in millimetres.

Figure 13 - Double Stack rolling stock outline dimensions

"Narrow Electric" Rollingstock Outline Dimensions

Bogie Centres: 16155 mm
Body Overhang: 3353 mm

Coordinates

Point	Lateral	Vertical
A	0	75
B	940	75
C	940	152
D	1220	152
E	1450	345
F	1450	1120
G	1485	1120
H	1485	3770
I	840	4420
J	0	4420

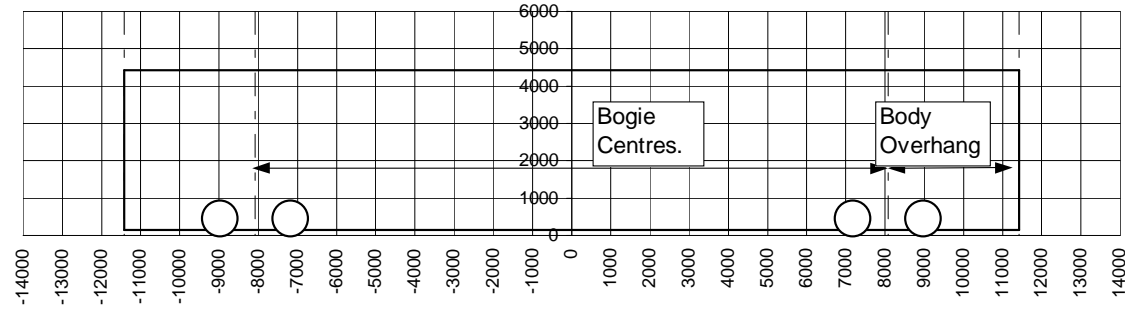
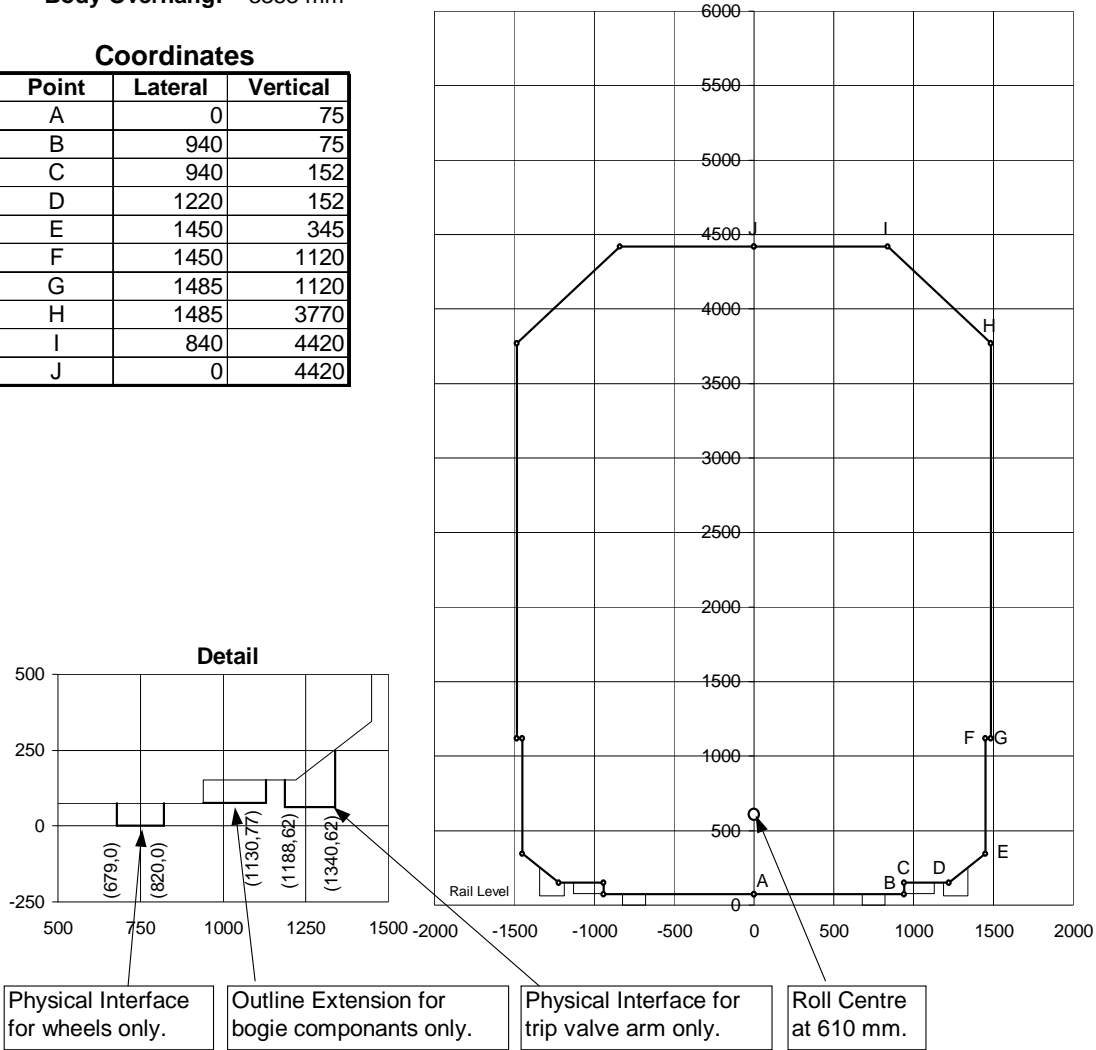

- All cross-section dimensions are symmetrical about the vehicle centreline.
- The origin for all horizontal coordinates is the vehicle centreline.
- The origin for all cross-section vertical coordinates is the rail level.
- The origin for all pantograph vertical coordinates is the contact position with fully worn contact brushes.
- All dimensions are in millimetres.

Figure 14 - Narrow Electric rolling stock outline dimensions

"Medium Electric" Rollingstock Outline Dimensions

Bogie Centres: 13945 mm
Body Overhang: 2755 mm

Coordinates

Point	Lateral	Vertical
A	0	75
B	940	75
C	940	152
D	1320	152
E	1525	305
F	1525	2930
G	1485	3795
H	870	4396
I	0	4406

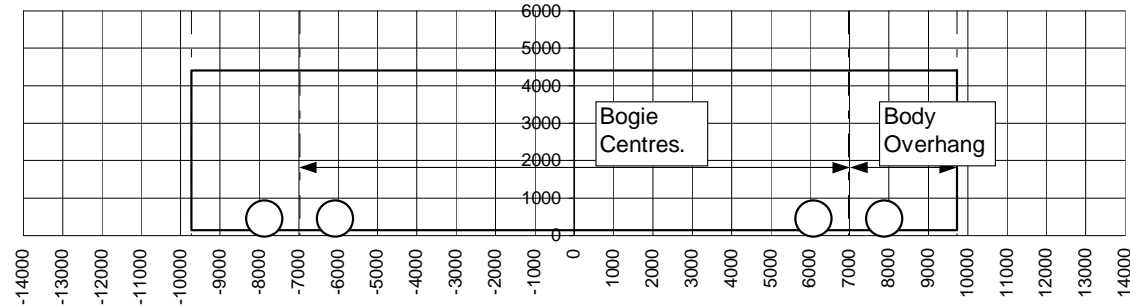
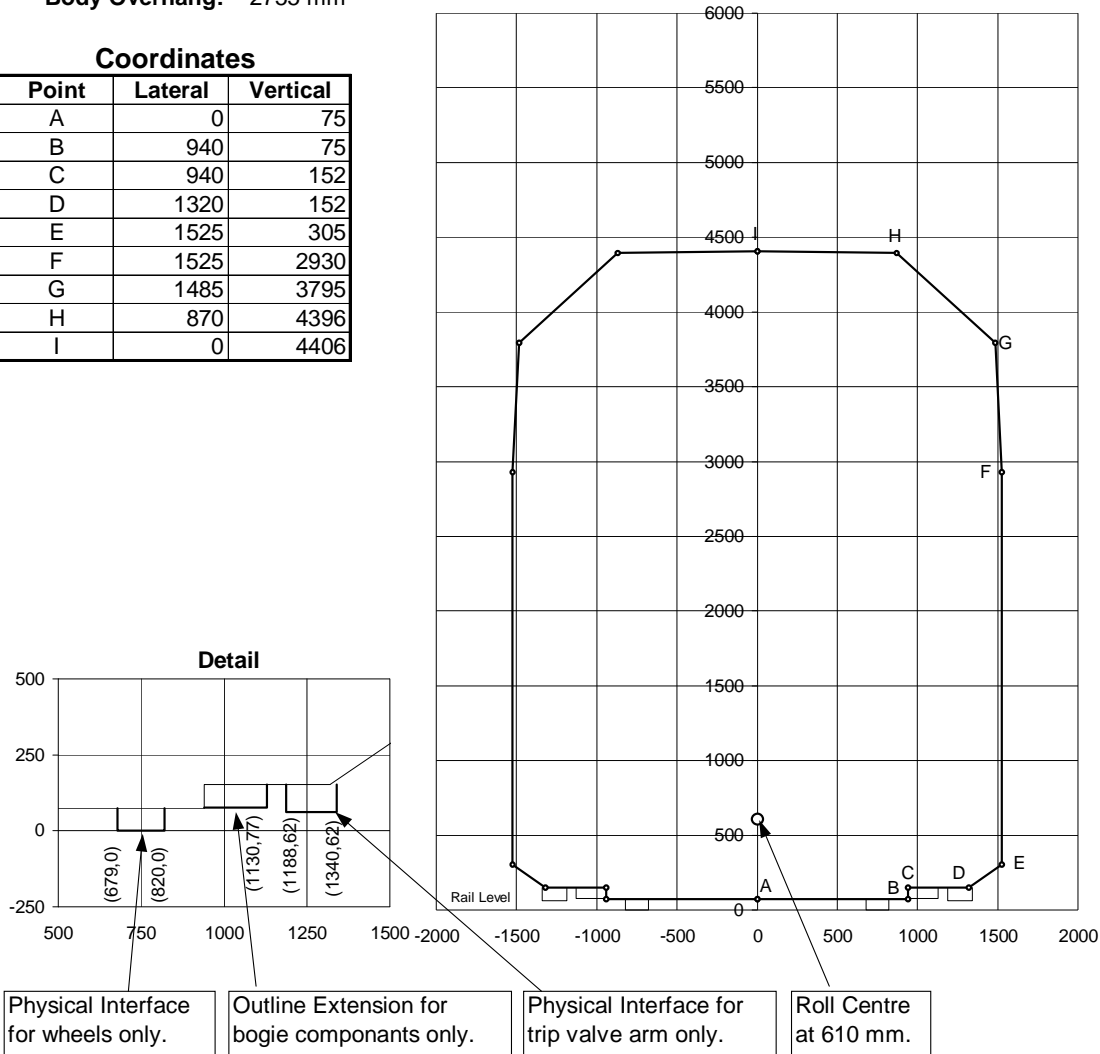

- All cross-section dimensions are symmetrical about the vehicle centreline.
- The origin for all horizontal coordinates is the vehicle centreline.
- The origin for all cross-section vertical coordinates is the rail level.
- The origin for all pantograph vertical coordinates is the contact position with fully worn contact brushes.
- All dimensions are in millimetres.

Figure 15 - Medium Electric rolling stock outline dimensions

"Extended Medium" Rollingstock Outline Dimensions

Bogie Centres: 13945 mm
Body Overhang: 2755 mm

Coordinates

Point	Lateral	Vertical
A	0	75
B	940	75
C	940	152
D	1320	152
E	1525	305
F	1525	1120
G	1540	1120
H	1540	3720
I	840	4420
J	0	4420

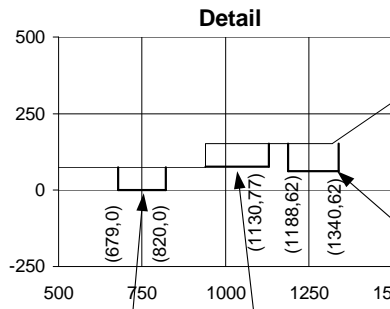
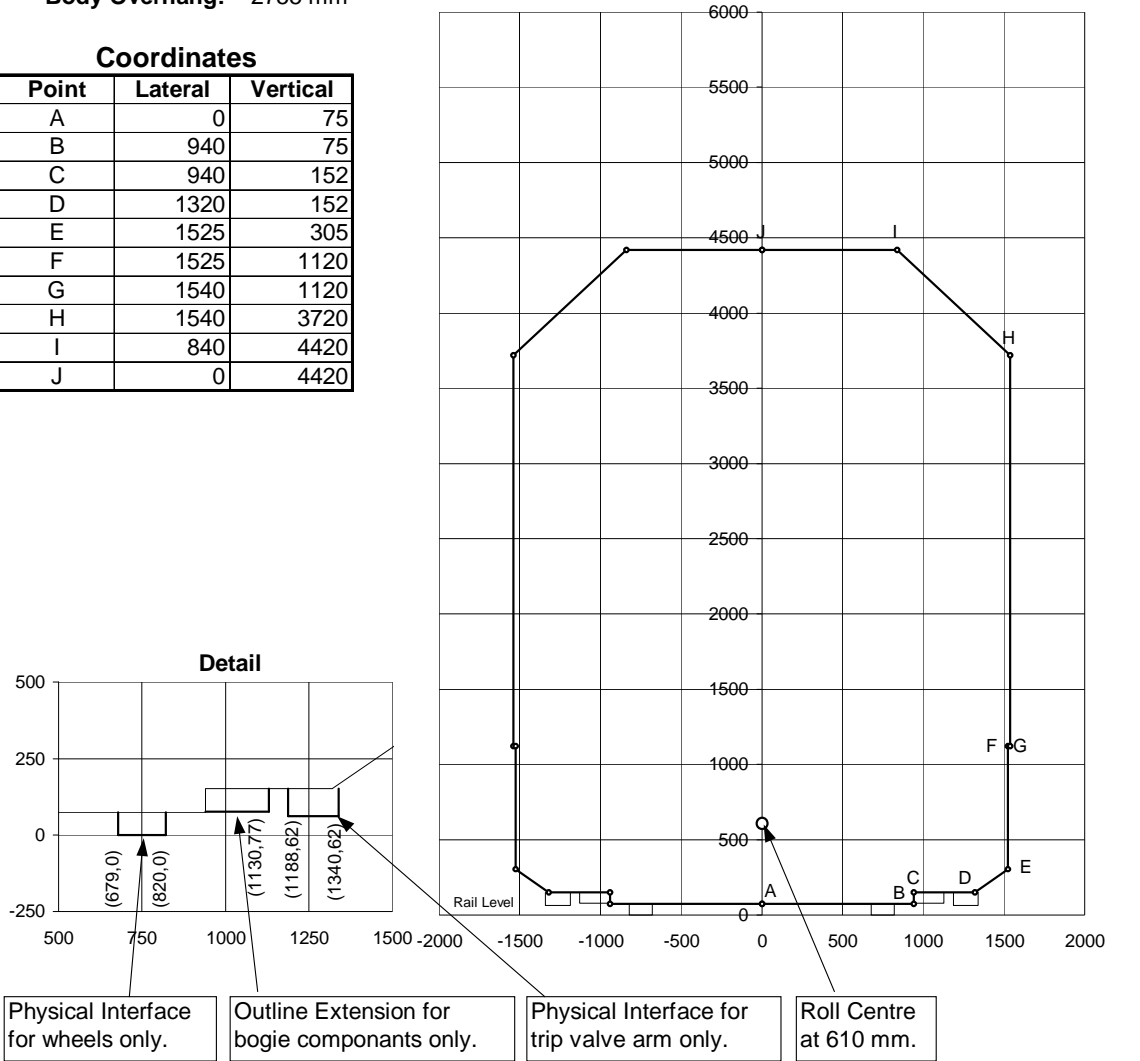

Physical Interface for wheels only.

Outline Extension for bogie components only.

Physical Interface for trip valve arm only.

Roll Centre at 610 mm.

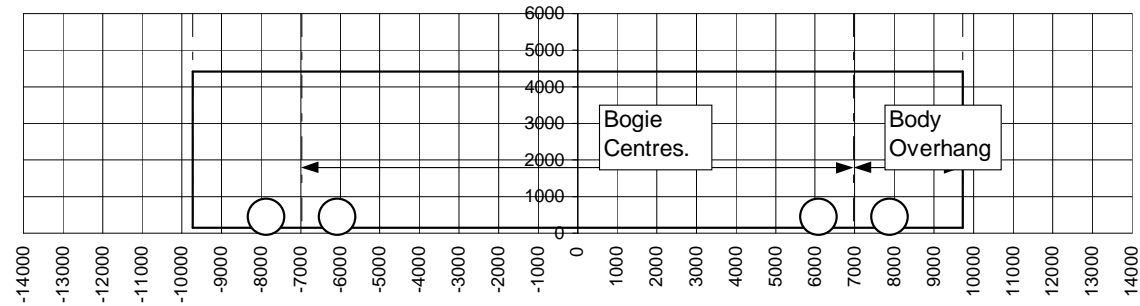

- All cross-section dimensions are symmetrical about the vehicle centreline.
- The origin for all horizontal coordinates is the vehicle centreline.
- The origin for all cross-section vertical coordinates is the rail level.
- The origin for all pantograph vertical coordinates is the contact position with fully worn contact brushes.
- All dimensions are in millimetres.

Figure 16 - Extended Medium Electric rolling stock outline dimensions

"Wide Electric" Rollingstock Outline Dimensions

Bogie Centres: 13105 mm
Body Overhang: 2998 mm

Coordinates

Point	Lateral	Vertical
A	0	75
B	940	75
C	940	152
D	1320	152
E	1525	305
F	1525	1120
G	1600	1120
H	1600	3660
I	840	4420
J	0	4420

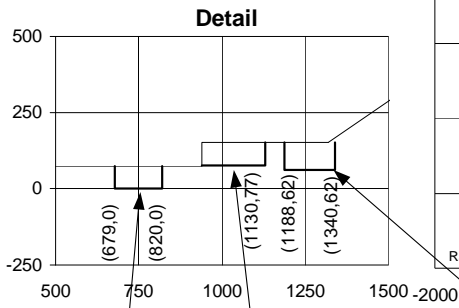
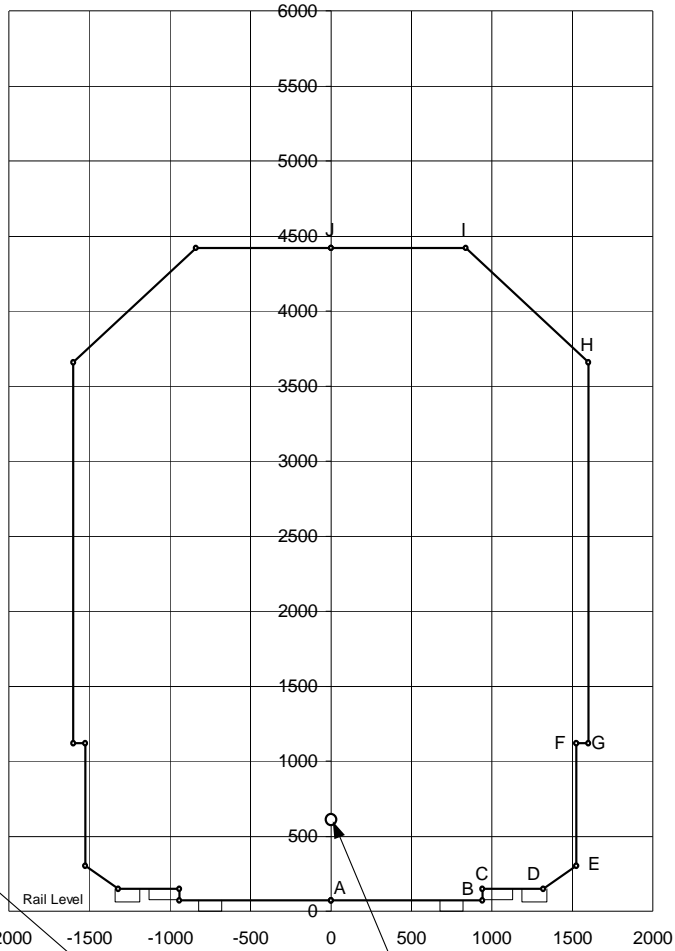

Physical Interface for wheels only.

Outline Extension for bogie components only.

Physical Interface for trip valve arm only.

Roll Centre at 610 mm.

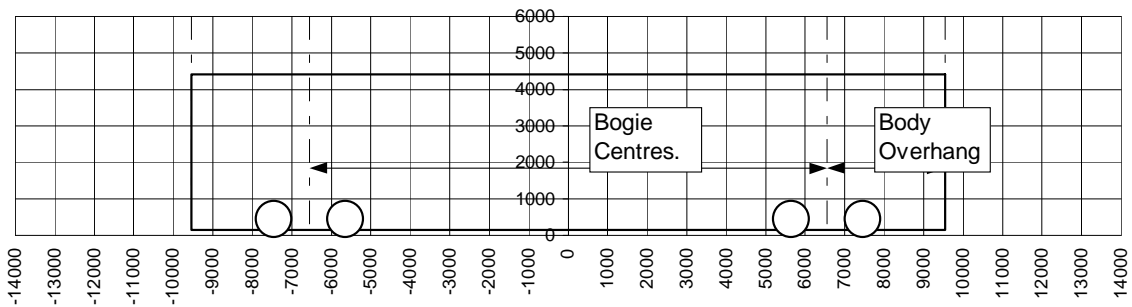

- All cross-section dimensions are symmetrical about the vehicle centreline.
- The origin for all horizontal coordinates is the vehicle centreline.
- The origin for all cross-section vertical coordinates is the rail level.
- The origin for all pantograph vertical coordinates is the contact position with fully worn contact brushes.
- All dimensions are in millimetres.

Figure 17 - Wide Electric rolling stock outline dimensions

"Out of Gauge Load" Rollingstock Outline Dimensions

Bogie Centres: 15240 mm
Body Overhang: 1980 mm

Coordinates

Point	Lateral	Vertical
A	0	75
B	940	75
C	940	152
D	1220	152
E	1448	345
F	1448	1219
G	1473	1219
H	1473	1270
I	1867	1270
J	1867	3048
K	1600	3658
L	914	4343
M	0	4343

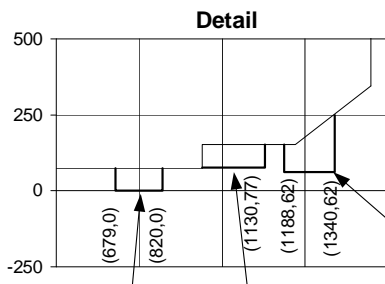
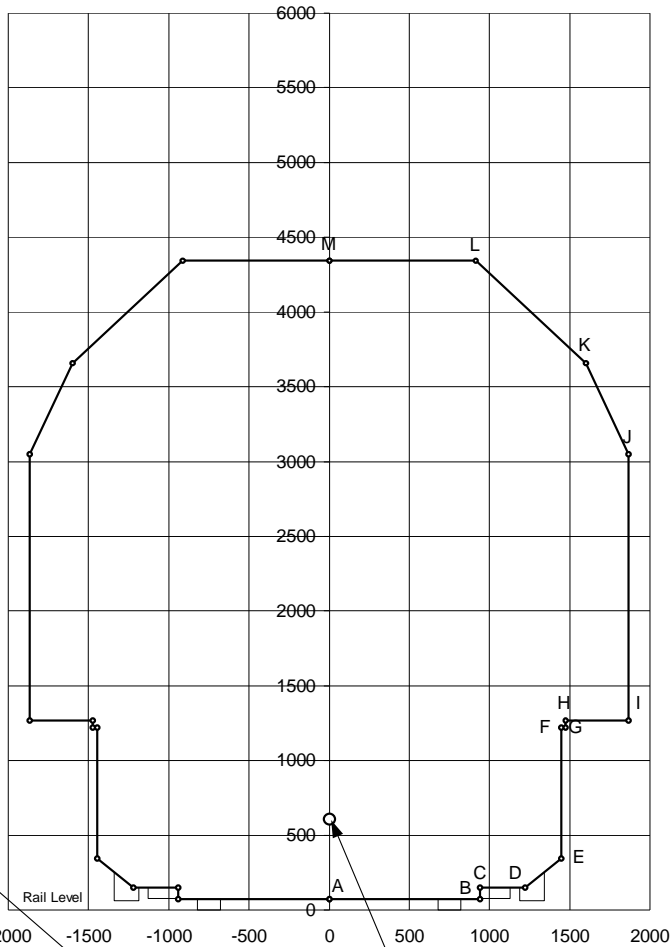

Physical Interface for wheels only.

Outline Extension for bogie components only.

Physical Interface for trip valve arm only.

Roll Centre at 610 mm.

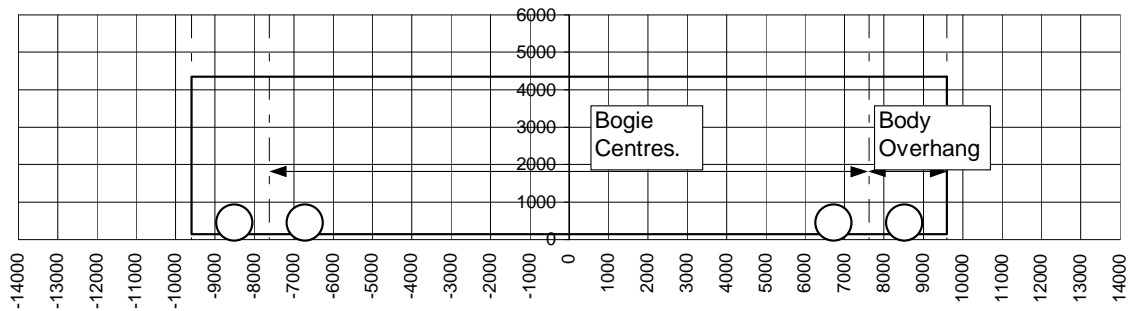

- All cross-section dimensions are symmetrical about the vehicle centreline.
- The origin for all horizontal coordinates is the vehicle centreline.
- The origin for all cross-section vertical coordinates is the rail level.
- The origin for all pantograph vertical coordinates is the contact position with fully worn contact brushes.
- All dimensions are in millimetres.

Figure 18 - Out of Gauge Load rolling stock outline dimensions

"NZZA Wagon" Rollingstock Outline Dimensions

Bogie Centres: 18300 mm
Body Overhang: 0 mm

Coordinates

Point	Lateral	Vertical
A	0	102
B	838	102
C	838	178
D	1143	178
E	1397	381
F	1397	1220
G	1790	1220
H	1790	3048
I	1524	3658
J	838	4343
K	0	4343

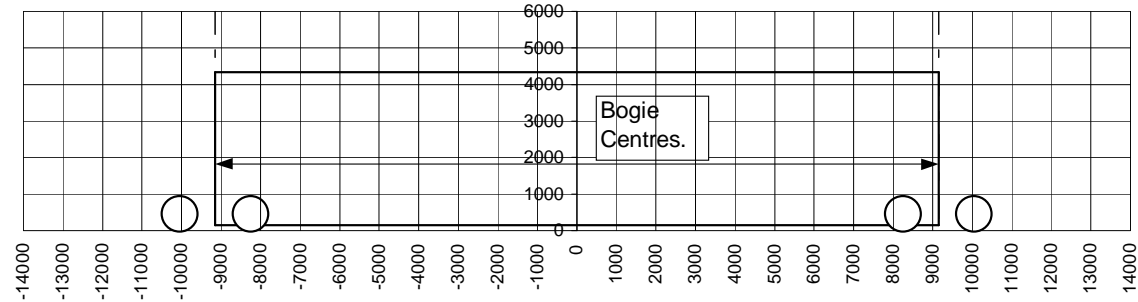
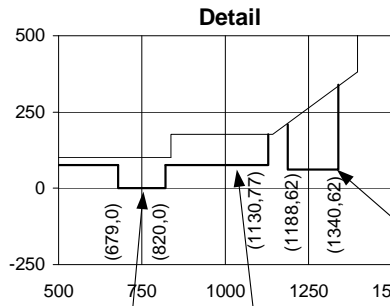
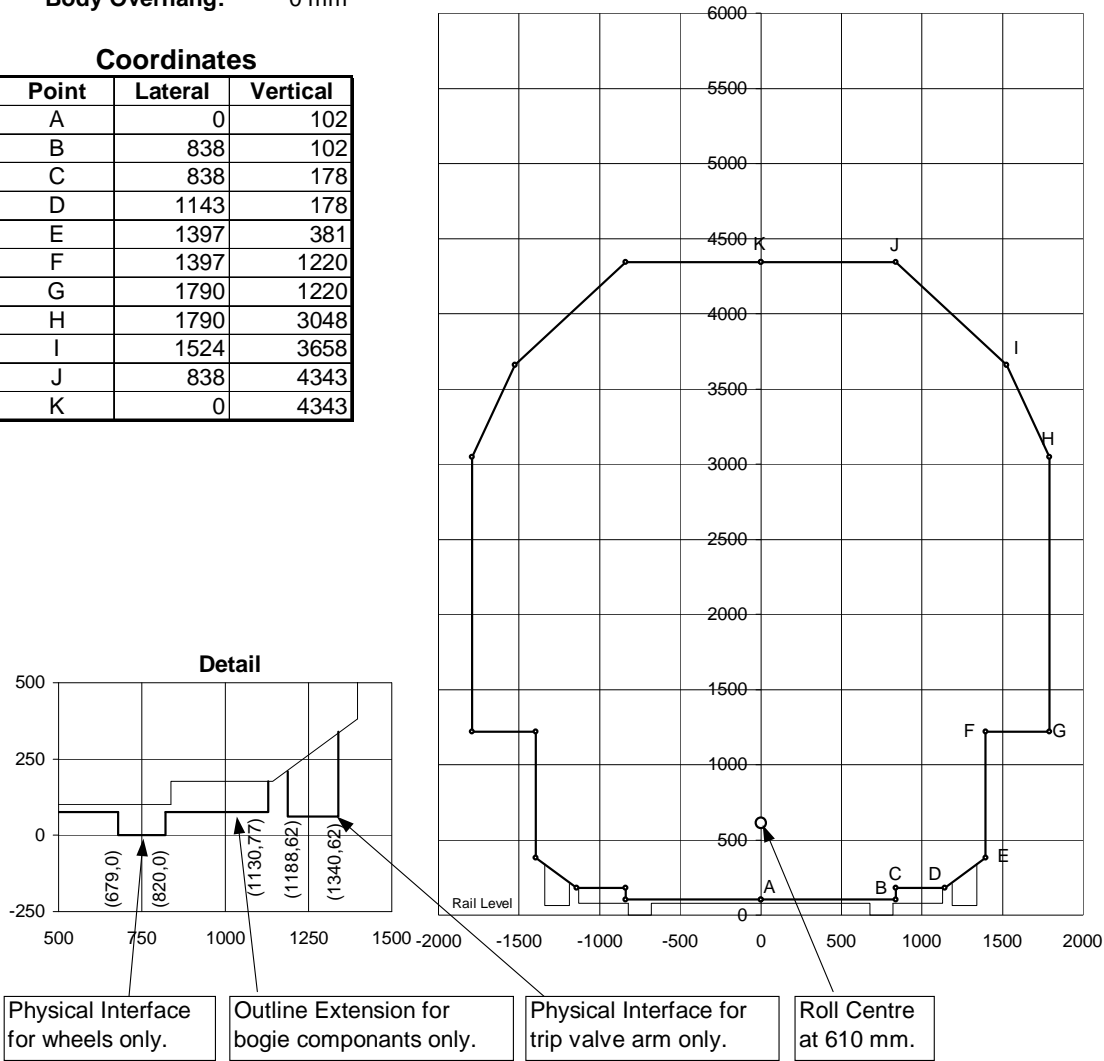

- All cross-section dimensions are symmetrical about the vehicle centreline.
- The origin for all horizontal coordinates is the vehicle centreline.
- The origin for all cross-section vertical coordinates is the rail level.
- The origin for all pantograph vertical coordinates is the contact position with fully worn contact brushes.
- All dimensions are in millimetres.

Figure 19 - NZZA Wagon rolling stock outline dimensions

Maximum Pantograph Outline

Coordinates

Lateral	Vertical
0	0
634	0
731	-29
796	-59
840	-89
1038	-288

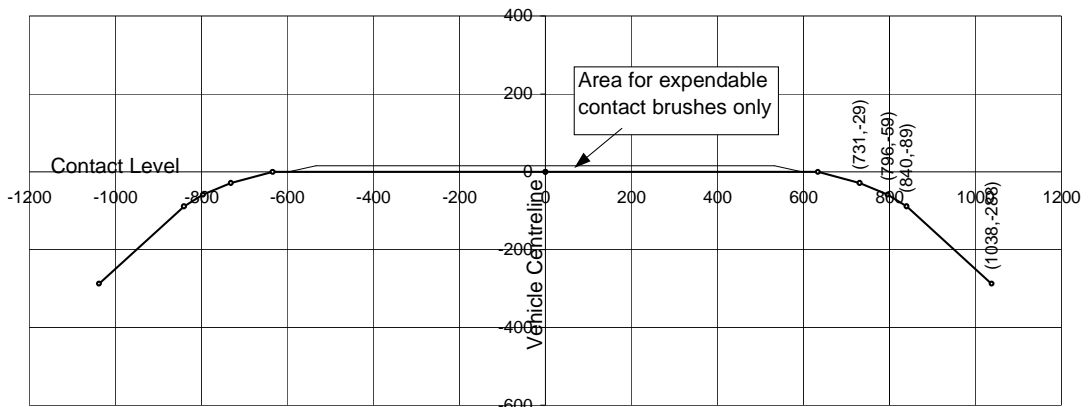

Designated Pantograph Area: = Bogie Centre position ± 1000 mm

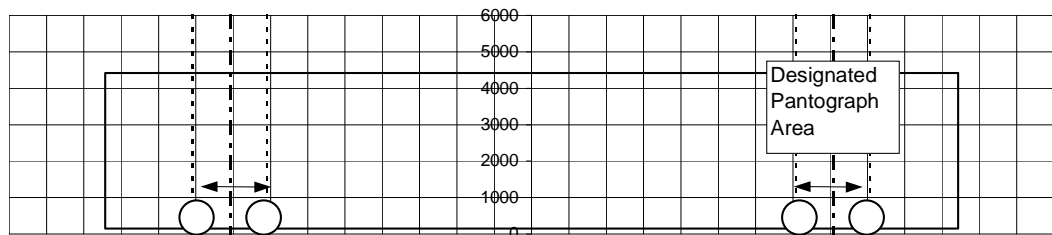

- All cross-section dimensions are symmetrical about the vehicle centreline.
- The origin for all horizontal coordinates is the vehicle centreline.
- The origin for all cross-section vertical coordinates is the rail level.
- The origin for all pantograph vertical coordinates is the contact position with fully worn contact brushes.
- All dimensions are in millimetres.

Figure 20 - Maximum Pantograph outline dimensions

Appendix C Definition of Symbols

Symbol	Description	Units
E_a	Design superelevation at the point in the track being analysed.	mm
E_{a_o}	Design superelevation of the track on the outside of a curve in dual track areas.	mm
E_{a_i}	Design superelevation of the track on the inside of a curve in dual track areas.	mm
E_{a_e}	Effective superelevation for the point in the track being analysed.	mm
R	Radius of the track at the point in the track being analysed.	m
R_e	Effective Radius of the track for the point in the track being analysed.	m
K	Co-efficient for determining horizontal displacement due to centre throw	
	$\frac{B_c^2}{8}$	
k	Co-efficient for determining horizontal displacement due to superelevation	
	$\frac{V}{1435}$	
B_c	Vehicle bogie centres.	mm
L	Vehicle length.	mm
V_c	Platform Height for a Concave Platform above design low rail level.	mm
V_v	Platform Height for a Convex Platform above design low rail level.	mm
V_s	Platform Height for a Standard Access Platform above design low rail level.	mm
V_L	Platform Height for a Level Access Platform above design low rail level.	mm
H_s	Platform Horizontal position for a Standard Access Platform from deign track centreline.	mm
H_L	Platform Horizontal position for a Level Access Platform from deign track centreline.	mm