

## Reference material

# ATP Project Specifications – Geographic Data for ATP

*This document is published as reference material to support the implementation of Automatic Train Protection as part of the roll out of the Advanced Train Control Migration System project.*

*The content described might be of assistance to individuals and organisations performing work on NSW Rail Assets.*

*When reading this document, any inconsistencies with Transport for NSW Network Standards shall be raised with the Asset Standards Authority (ASA) for clarification.*

*This document does not comply with accessibility requirements (WCAG 2.0). If you are having trouble accessing information in these documents, please contact the [ASA](#).*

Authorised by: Chief Engineer, Asset Standards Authority  
Published: November 2018

### Important message

This document is developed solely and specifically for use on the rail network owned or managed by the NSW Government and its agencies. It is not suitable for any other purpose. You must not use or adapt it or rely upon it in any way unless you are authorised in writing to do so by a relevant NSW Government agency.

If this document forms part of a contract with, or is a condition of approval by, a NSW Government agency, use of the document is subject to the terms of the contract or approval.

This document is published for information only and its content may not be current.

## ATP PROJECT SPECIFICATIONS

### GEOGRAPHIC DATA FOR ATP

DeskSite Reference: 2741164

Guideline – Applicable to Implementation of ATP – ATP Project

|                    |   |
|--------------------|---|
| Status:            | Issued for Approval   |
| Version:           | 1.5   |
| Branch:            | <b>Infrastructure &amp; Services</b>  |
| Business unit:     | ATP Program   |
| Date of issue:     | 16/5/2017   |
| Review date:       | N/A   |
| Audience:          | ATP designer, installer and project delivery  |
| Asset classes:     | <input checked="" type="checkbox"/> Heavy Rail; <input type="checkbox"/> Light Rail; <input checked="" type="checkbox"/> Multi Sites;<br><input checked="" type="checkbox"/> Systems; <input type="checkbox"/> Fleets   |
| Project type:      | Major   |
| Project lifecycle: | <input type="checkbox"/> Feasibility; <input checked="" type="checkbox"/> Scoping; <input type="checkbox"/> Definition;<br><input checked="" type="checkbox"/> Construction readiness; <input checked="" type="checkbox"/> Implementation;<br><input checked="" type="checkbox"/> Finalisation; <input type="checkbox"/> Not applicable |
| Process owner:     | Project Director  |

Reference material only

**Document Approval**

|  |  |                                    |
|--|--|------------------------------------|
| <p><b>Authored by:</b><br/>Luke Lee<br/>Trackside Data Design<br/>I&amp;S, ATP Project</p>                                       |    | <p><b>Date:</b> 20/09/2018</p>     |
| <p><b>Reviewed by:</b><br/>Paul Hartley<br/>Senior Rail Systems Manager<br/>I&amp;S, ATP Project</p>                             |    | <p>20/09/2018<br/><b>Date:</b></p> |
| <p><b>Reviewed by:</b><br/>Ian Connolly<br/>Manager Safety Assurance<br/>I&amp;S, ATP Project</p>                                |    | <p>20/9/2018<br/><b>Date:</b></p>  |
| <p><b>Reviewed by:</b><br/>Andre Younes<br/>Manager Operational Integration<br/>I&amp;S, ATP Project</p>                         |    | <p>21 Sep 18<br/><b>Date:</b></p>  |
| <p><b>Reviewed and Accepted by:</b><br/>Frederic Tricoche<br/>Principal Engineering Manager Systems<br/>I&amp;S, ATP Project</p> |  | <p>21/09/2018<br/><b>Date:</b></p> |
| <p><b>Approved for Release by:</b><br/>Geoff Webb<br/>ATP Project Director<br/>I&amp;S, ATP Project</p>                          |  | <p>25/09/2018<br/><b>Date:</b></p> |

Reference material only

**Document History**

| Version | Date of Issue | Author       | Summary of change  |
|---------|---------------|--------------|--|
| 0.1     | 30/03/2016    | S. Rahman    | Initial draft  |
| 0.2     | 07/06/2016    | S. Rahman    | Updated after internal review as per DRS [DeskSite: 5082571]   |
| 0.3     | 28/07/2016    | S. Rahman    | Updated after internal review as per DRS [DeskSite: 5082571]   |
| 0.4     | 26/9/2016     | S. Rahman    | Updated after internal review as per DRS [DeskSite: 5082571]   |
| 0.5     | 12/10/2016    | S. Rahman    | Updated after internal review as per DRS [DeskSite: 5082571] and issued to Sydney Trains for comments  |
| 0.6     | 04/11/2016    | S. Rahman    | Updated after internal review as per DRS [DeskSite: 5082571]   |
| 0.7     | 12/12/2016    | S. Rahman    | Updated after internal review as per DRS [DeskSite: 5082571] and issued for internal review only   |
| 0.8     | 23/12/2016    | S. Rahman    | Minor changes to correct/clarify wording throughout document.<br>Major inclusion/change to section 6.4 – use of OHWS and section 7.3 measurement procedure |
| 1.0     | 27/01/2017    | S. Rahman    | Issued for approval  |
| 1.1     | 9/5/2017      | S. Rahman    | Changed as per CR 453, 481 & 574   |
| 1.2     | 12/5/2017     | S. Rahman    | Changes as per internal review of v1.1   |
| 1.3     | 16/5/2017     | S. Rahman    | Changes as per internal review of v1.2   |
| 1.4     | 5-7-18        | J. Firmstone | Updated with latest Site Certification Form and ASDO requirements.   |
| 1.5     | 20/09/2018    | L.Lee        | Updated to CR1509<br>Updated after internal review as per #DS-6138826  |

Reference material only

Reference material only

## Foreword

This guideline forms a part of ATP Project Specifications which detail the requirements for the implementation of ATP on the TfNSW heavy rail network.

This guideline specifically covers the sources and use of Geographic Data required as part of ATP Trackside implementation.

To gain a complete overview of ATP signalling design requirements, this document should be read in conjunction with the ATP suite of signalling design principle and guideline modules.

### Note

**The following guideline is to be used by AEO's engaged by the ATP program for the implementation of ATP only. This is to ensure that a consistent methodology is applied.**

**It has been produced during the development of the ATP Project Specifications and subsequent further development of this guideline may be required as the specifications evolve.**

**It is an interim document until the ASA Guideline is published.**

## Table of Contents

|  |           |
|--|-----------|
| <b>Document Approval</b> .....   | <b>2</b>  |
| <b>Document History</b> .....  | <b>3</b>  |
| <b>1 Introduction</b> .....  | <b>6</b>  |
| <b>2 Purpose</b> .....   | <b>8</b>  |
| 2.1 Scope .....  | 8         |
| 2.2 Application .....  | 8         |
| <b>3 Reference documents</b> .....   | <b>9</b>  |
| <b>4 Terms and definitions</b> .....   | <b>10</b> |
| <b>5 Overview of Use of Geographic Data</b> .....                                    | <b>12</b> |
| 5.1 Input Source for Location Data .....   | 14        |
| 5.2 Input Source for Gradient Data .....   | 17        |
| <b>6 Use of Site Certification Form</b> .....  | <b>18</b> |
| 6.1 Identifying Balise Position and Locations for Verification.....                  | 23        |
| 6.2 Balise Installation and Site Verification .....                                  | 24        |
| 6.3 Site Verification of Geographic Location Data.....                               | 25        |
| 6.4 Acceptable Reference Assets .....  | 26        |
| <b>7 Site Measurement Process</b> .....  | <b>27</b> |
| 7.1 Measurement Points.....  | 27        |
| 7.2 Measurement Tools .....  | 35        |
| 7.3 Measurement Procedure .....  | 35        |
| <b>8 ATP Change Management Workgroup</b> .....                                       | <b>37</b> |
| <b>9 Record of Geographic Data for Maintenance</b> .....                             | <b>38</b> |
| <b>Appendix A. Site Certification Form</b> .....                                     | <b>39</b> |
| <b>Appendix B. Reference Assets and Target Locations for Different ATP Functions</b> | <b>41</b> |
| <b>Appendix C. RFI for GIS Extract</b> .....   | <b>56</b> |
| <b>Appendix D. Handling of inconsistency in WebGIS</b> .....                         | <b>58</b> |

Reference material only

## 1 Introduction

Transport for New South Wales (TfNSW) is using the European Train Control System (ETCS) to provide Automatic Train Protection (ATP) functionality on the TfNSW heavy rail network.

In ETCS, trackside equipment transmits data (geographic data, speed limits, signalled proceed authorities, and other related data) to on-board equipment. The on-board equipment uses this information and pre-programmed rolling stock parameters to calculate brake interventions to the train within safe speed and distance limits.

ETCS operates in numerous levels (defined mainly by the type of communication between trackside and on-board equipment). Level 0 is defined for operating an ETCS fitted train on track which is not fitted with ETCS trackside equipment. In Level 1, trackside equipment transmits information to the train primarily by track-mounted transponders called Eurobalises (balises), and is intended to overlay on existing signalling without alteration of the signalling system. In Level 2, balises are primarily used for position reference and some fixed values, with operational information transmitted to the train by radio. Level 2 still relies on fixed block train detection (track circuits and/or axle counters), but lineside signals become redundant. Level 3 is specified as a moving block system with responsibility for train integrity moved from track based detection to an on-board function.

It is intended that the TfNSW network will eventually use a mixture of Level 1 and Level 2, dependent on operational characteristics of given areas, operating primarily in Full Supervision (FS) mode, to enforce speed and distance limits. This combined with intelligent rail traffic management systems, will be known as Advanced Train Control System (ATCS).

Due to the operational complexities of the TfNSW network and services (size of network, and size and deployment of rolling stock fleet and train crewing workforce), the path to FS is long and complicated. As a transitional arrangement, the Advanced train control Migration System (ATP) has been devised. Using Limited Supervision (LS) mode in Level 1, ATP is designed primarily for rapid deployment to manage risks which are not already protected by other engineered systems, and enable personnel to become familiar with the equipment before a more complex functionality is introduced.

Note – ATP is not intended to address/mitigate driver incapacitation, although it will keep the train within safe speed and distance limits (limit of authority management is

Reference material only

only applicable to the buffer stop protection) until the driver incapacitation defences intervene.

Geographic Data related to the rail infrastructure is used during ATP design to determine balise placement and also to configure the trackside data sent by the balises to the on-board equipment. Geographic data required for ATP has two components; location and gradient.

- The **Location** component is the longitudinal position of ATP Points of Interests (POIs) with respect to the track centreline. An ATP POI can be;
  - An existing asset, e.g. a signal,
  - Part of an existing asset, e.g. toe of a point where the turnout itself is the existing asset, or
  - A new asset, e.g. a balise.

The location data must have an accuracy of +/-2m and must allow for the calculation of relative distances between the POIs (i.e. kilometrage reference cannot be used as the location since relative distances cannot be calculated from these references). For the ATP project, Sydney Trains Geospatial Information System (GIS) data must be used as location data input for the existing network infrastructure.

- The **Gradient** component is the grade or slope for a section of the track where ATP target speed monitoring (TSM) is being implemented. The gradient data available from Sydney Trains Vertical Alignment Database (VAD) with reference from Survey Alignment Database (SAD) must be used as gradient data input for ATP.

Reference material only



## 2 Purpose

### 2.1 Scope

This guideline:

- Specifies the input geographical data for ATP design,
- Details the activities required to be carried out by the signal designer for;
  - The balise installation in correct locations, and
  - The site verification of geographic location data.
- Details of the activities required to manage changes between input data and site measurements,
- Outlines the geographic measurements required to be handed over to Sydney Trains for maintenance.

This guideline:

- Does not detail configuration change management requirements for keeping geographic data up to date either during or after the completion of ATP project. It is assumed the project and/or maintainers of ATP will follow Sydney Trains configuration change management procedures. Refer to Sydney Trains document, Sydney Trains Configuration Management Plan for further detail on this process.

### 2.2 Application

This guideline is applicable to the ATP system integrator (TfNSW), signal designer, data designer, balise installer and verifier of geographic data.

This guideline can also be used by the maintainer of ATP in relation to source and use of geographic data for ATP.

Reference material only

### 3 Reference documents

The following documents are cited in the text. For dated references, only the cited edition applies. For undated references, the latest edition of the referenced document applies.

#### International Standards

European Rail Agency (ERA) Specifications, Baseline 3 Maintenance Release 1

#### ASA Standards

T HR SC 10031 ST Signalling Design Principle – ETCS Level 1

ESC 210 Track Geometry and Stability

T HR TR 13000 ST Railway Surveying

SPG 0706 Installation of Trackside Equipment

#### Sydney Trains Documents

AISS-WI-056 WebGIS Help Guide

AMD-AMP-PL-001 Sydney Trains Configuration Management Plan

#### ATP Requirements

ATP System Requirements Specifications

ATP Trackside Subsystem Requirements Specifications

#### ATP Project Specifications

Gradient Simplification Design Guideline

Balise Placement and Metal Mass Guide

Reference material only

## 4 Terms and definitions

The following terms and definitions apply in this document:

|                        |  |
|------------------------|--|
| <b>Accuracy</b>        | Measurement tolerances for location data, in the context of this guideline, the true value is the actual location of a POI as found on site  |
| <b>AEO</b>             | Authorised Engineering Organisation  |
| <b>AIDF</b>            | Asset Information Delivery Form  |
| <b>AMS</b>             | Advanced train control Migration System  |
| <b>ATP</b>             | Automatic Train Protection   |
| <b>BG</b>              | Balise Group   |
| <b>BRM</b>             | Balise Reference Mark  |
| <b>BMM</b>             | Big Metal Mass   |
| <b>DPU</b>             | Data Pickup Unit   |
| <b>DSS</b>             | Detailed Site Survey   |
| <b>ETCS</b>            | European Train Control System  |
| <b>IRJ</b>             | Insulated Rail Joint   |
| <b>GIS</b>             | Geographic Information System  |
| <b>OHWS</b>            | Overhead Wiring Structure  |
| <b>POI</b>             | Points of Interest   |
| <b>Reference Asset</b> | An existing asset used as reference to guide installation of balises. A specified distance from this asset along the track centreline represents the balise location in the network. |
| <b>RFI</b>             | Request for Information  |
| <b>SAD</b>             | Survey Alignment Database  |

Reference material only

Reference material only

|                             |   |
|-----------------------------|---|
| <b>SCF</b>                  | Site Certification Form   |
| <b>SI Unit</b>              | Air core inductor   |
| <b>Target Location</b>      | The Target Location refers to a point where a reduced speed, stop/trip instruction and/or an ETCS message comes into effect. Also, the location of an intermediate speed sign(s) managed by a controlled BG shall be considered as a target location for the purpose of populating the SCF. Note: if the associated balise group can be placed within 100m of this target location then this is also used as the Reference Asset for that balise group. |
| <b>T/C</b>                  | Test and Commissioning  |
| <b>TCM</b>                  | Track Control Marks are points of reference measured by Sydney Trains surveyors and marked on a structure with a survey plaque.   |
| <b>TBC</b>                  | Track Base Code   |
| <b>TSM</b>                  | Target Speed Monitoring   |
| <b>VAD</b>                  | Vertical Alignment Database   |
| <b>Vertical Centre Line</b> | The vertical centre when the infrastructure is viewed perpendicular to the running rail.  |

## 5 Overview of Use of Geographic Data

The flow of geographic data through various stages of the ATP project is shown in Figure 1. Note this guideline does not detail all of the activities shown in Figure 1.

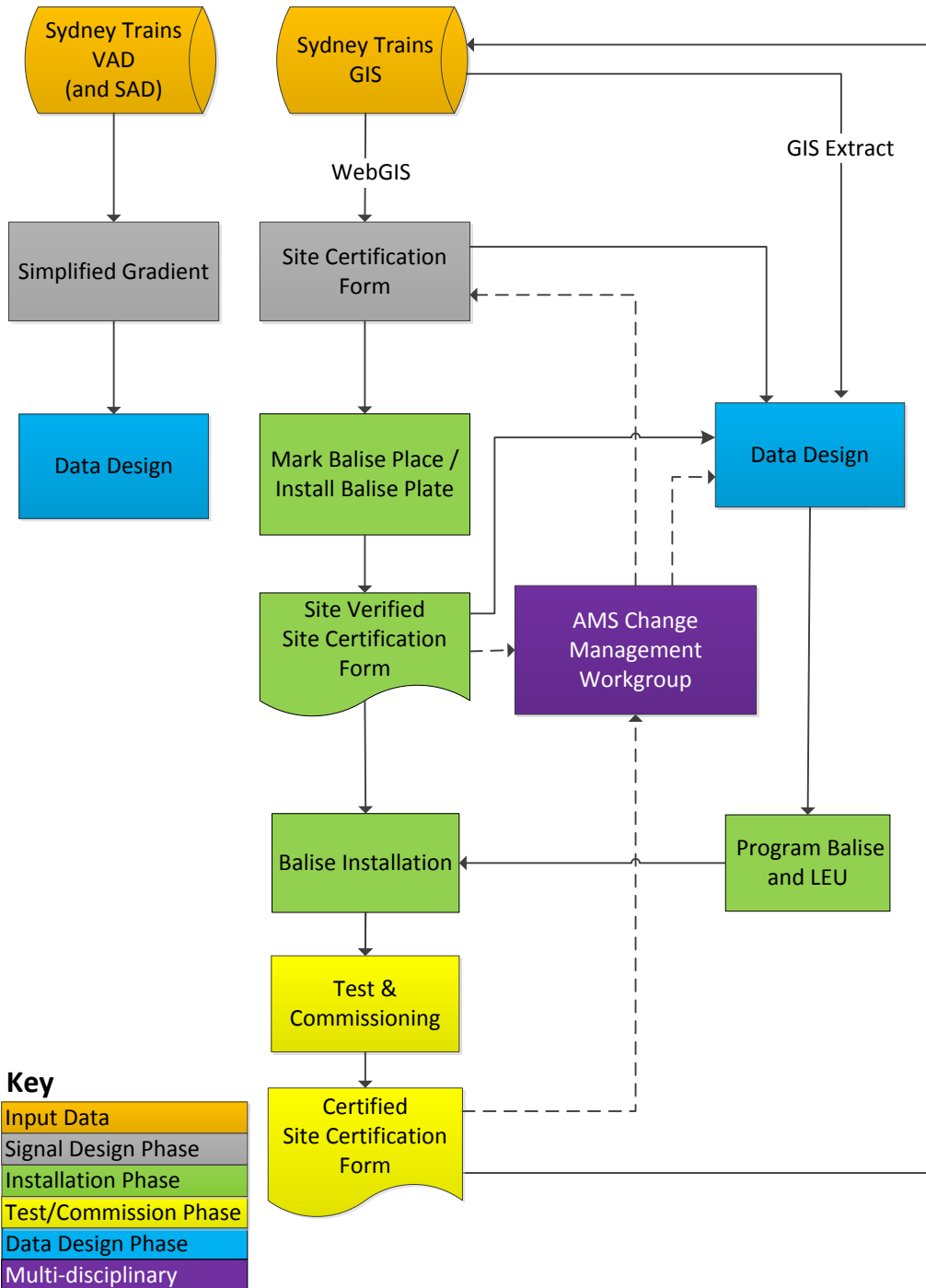

Figure 1: Flow of Geographic Data through ATP Project

Solid lines in the Figure 1 indicate mandatory transfer of data, while the dashed lines represent conditional transfer of data.

Reference material only

The signal designer must use Sydney Trains GIS and Gradient data as the geographic data input to produce the associated Site Certification Form (SCF) and simplified gradients respectively. Refer to section 5.1 for further details on input sources for location data and section 5.2 for further details on the use of gradient data for ATP.

The SCF and simplified gradient must be provided to the data designer. A blank copy of the SCF is provided in Appendix A. Part A of the SCF is used to place the balises in their correct location on site and Part B of the SCF is used for site verification of geographic location data.

The installer of ATP equipment shall carry out a site audit and verify the locations of the balises in SCF Part A, as per section 6.2. The installer must verify the input geographic location using SCF Part B prior to installation of the balises. This can be carried out at the same time as marking of the balise locations. The updated SCF must be provided to the data designer.

The data designer must finalise data using the verified location of balises as provided in SCF Part A and adjust the location of existing assets where required using the verified locations given in SCF Part B.

Any further changes must be raised in ATP Change Management Workgroup. Changes can result from not being able to install balises in their designed/marked location and/or due to configuration changes to network infrastructure. The updated SCF will need to be re-verified by the installer.

If there are any changes between install and test and commissioning (T&C), the updated SCF will need to be provided to the signal and/or data designers depending on the nature of the change.

The certified copy of the SCF after T&C must be provided to Sydney Trains GIS unit for correction and/or maintenance of location data including the balise locations.

Refer to section 6 for details of the activities related to the use of the SCF, section 7 for details on the acceptable measurement process, section 8 for details on the ATP Change Management Workgroup and to section 9 for further details on handover of geographic data to Sydney Trains.

Reference material only

## 5.1 Input Source for Location Data

### 5.1.1 Primary Source for Location Data

Sydney Trains GIS data must be used as the input for location data for all existing infrastructure. Various interface and/or extracts of the GIS data are possible; two of the most common formats of GIS data are described below:

- **WebGIS (Including WebGIS Network Viewer)** is a web based application provided by Sydney Trains which provides a visual interface to the GIS data. The WebGIS also offers various functions to aid the design process, refer to the Sydney Trains document: AISS-WI-056 WebGIS Help Guide for further information on the use of this application. This document can be accessed following the link under the 'Help' menu within the WebGIS application. Refer to Appendix D for examples of the various functions available within WebGIS to improve the accuracy of measurements.
- **GIS Extract** is an extract of GIS data related to the ATP POIs only, provided by Sydney Trains GIS team upon request from the project. A guideline for details to include in a Request for Information (RFI) for a GIS Extract from Sydney Trains is provided in Appendix C. Since this extract is only a snap shot of the GIS database, it is prone to becoming mis-aligned with actual configuration on site and also WebGIS itself. The Data designer needs to seek updated extracts from GIS and/or manage the changes through existing notifications/controls as per Sydney Trains Configuration Control Procedures. As a minimum a new extract should be requested at the start of Data Design for each ATP sector.

### 5.1.2 Alternative Sources for Location Data

Alternative input sources can be used only if the following conditions are met.

- If the location for a POI is not available from Sydney Trains GIS at the required accuracy of +/-2m, and
- The alternative source contains OHWS or other assets which can be used to verify the locations of the Reference Assets and/or the Target Locations on site.

The alternative sources listed below are in the order of preference.

- **Detailed Site Survey (DSS) drawings**  
DSS plans are scaled drawings; therefore distances measured from DSS can be used as an input to the ATP project. DSS drawings contain the OHWS and

Reference material only

use the same labels for them as shown on GIS. The OHWS can be used for site verification of input location data as per section 6 and relate the DSS locations to GIS data.

- MetroNet Transponders are not accurately shown on GIS. The latest **MetroNet Transponder Maps** provided by Sydney Trains Operations Technology Unit must be used for location of MetroNet Transponders.

The MetroNet Transponder location is given either as an actual distance from an existing asset, e.g. 9m Sydney Side of Signal 97.4 or, as a description relating the location to existing assets e.g. Centre of a Station Platform.

Where a distance from existing assets or OHWS are provided these can be used as an input. Where a description is provided, the related asset location on GIS shall be used to estimate the location of the MetroNet transponder, e.g. estimated position from GIS for mid-point of the associated platform shall be used if the description says the transponder is located at the centre of station platform. The existing asset and/or OHWS can also be used to relate the data from the MetroNet Transponder Maps to GIS.

Note that MetroNet transponders are suitable to be used as Reference Assets. However, balises cannot be installed within a certain distance from MetroNet Transponders. The signal designer shall use the 'Site Specific Notes' section of the SCF to instruct the site installer of the minimum distance required to be maintained.

Once the location data from the alternative source is related to GIS Data, it can also be aligned with the gradient data from Sydney Trains using the km references from GIS.

The location data source used must be clearly specified including the version and/or last updated date of the source in the supporting documentation to accompany the signal design submission.

### 5.1.3 Distance Calculations for ATP Design

All distance measurements for all ATP design must be derived using;

- The **Network Trace** function in WebGIS, or
- The **distance\_from\_start\_of\_tbc\_meters** given in the GIS Extract.

Track Base Code (TBC) refers to a section of a track between two terminating nodes, e.g. from the buffer stop to a turnout etc. TBCs can be thought of as analogous to tracks for ATP, e.g. the Up Main North track is one particular TBC



Reference material only

while the Down Main North is a separate TBC etc. Note that in the GIS Extract, the turnouts also have their own TBCs.

The field **distance\_from\_start\_of\_tbc\_meters** provides the rolling distance from the start node of the track to each of the POIs for the track associated with that POI. Thus, this field can be used to calculate rolling distance between two POIs. Note that some POIs may appear multiple times in a GIS Extract with different TBCs associated to them, for example ‘toe of points’ are usually related to two different TBCs, one on the main track and one on the specific TBC used for the turnout, as shown in Figure 2.

The rolling distance calculated using the GIS Extract file should exactly match the distance derived by using ‘Network Trace’ function on WebGIS. However, since the use of ‘Network Trace’ function has the chance of introducing human error while placing the markers, the two can differ by a small amount, usually less than a meter.

As a result, rolling distance calculated using GIS Extract is preferred, unless a visual guide to the area is required to make the measurements and/or support decisions related to the measures. It is also easier to automate calculations of distances using software, e.g. MS Excel when working with the GIS Extract. As such, using WebGIS ‘Network Trace’ is more suitable and recommended for measuring distances during signalling design; refer to section 6 for further details. The use of GIS Extract is more suitable and recommended for data design.

When using the GIS Extract, the distances between POIs located on different tracks must be calculated by adding together distances in the individual tracks/TBCs as shown in Figure 2.

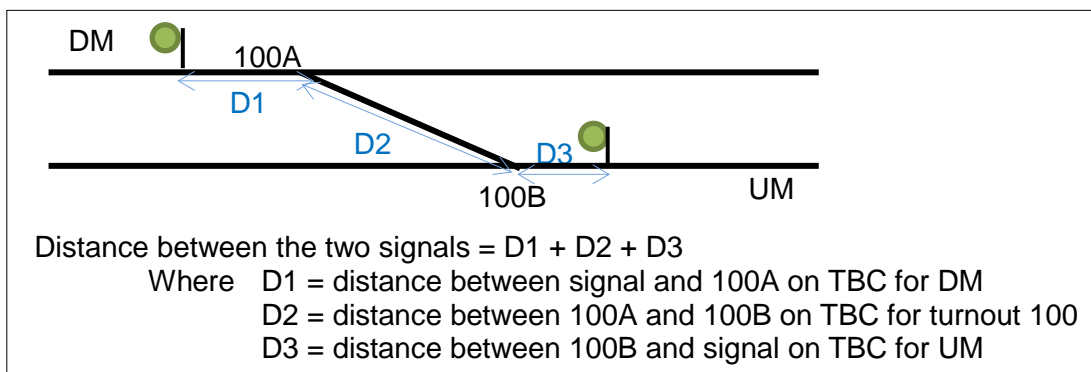

Figure 2: Distance Calculation for POIs on separate track

The Network Trace function should allow the signal and data designer to trace the distance between any two POIs as long as there is a valid path between them, e.g. via a turnout as shown in Figure 2.

If it is not possible to use the Network Trace function in the WebGIS or calculate distances using the GIS Extract, then one of the following methods can be used.

- Using approved scaled drawings, like Detail Site Survey drawings etc.
- Using 'Measure' function in WebGIS with aerial image. This function gives the point to point measure along a straight line. Thus, multiple measures need to be added to give the complete distance along curved tracks and if POIs are located on different tracks.
- Using the corresponding linear references in WebGIS.

If it is not possible to use any of the methods described above for calculating distance, the signal and data designer shall consult TfNSW on an appropriate alternative source through an RFI.

The signal designer must record the source and method used in the supporting documentation to accompany the signal design submission.

#### **5.1.4 Site Verification Requirement for Location Data**

Input location data for all Reference Assets and Target Locations need to be site verified for all of the above mentioned sources including Sydney Trains GIS.

Furthermore, the installation of the balise will need to be certified with reference to the Reference Asset, and for any other requirements mentioned in the ASA Signalling Design Principle – ETCS Level 1. Refer to section 6, Appendix A and Appendix B for further details.

### **5.2 Input Source for Gradient Data**

#### **5.2.1 Primary Source for Gradient Data**

Gradient data extracted by Sydney Trains Survey Office using the VAD with reference from SAD is provided to the signal designer.

The signal designer must use the rules provided in the ATP Project Specification: Gradient Simplification Design Guideline to simplify the gradient prior to using it for ATP design. As per the Gradient Simplification Design Guideline, the signal designer must record the furthest target location and the lengths over which the gradients apply. The furthest target location can be identified in the location data using its asset name and

track description, and thus can be used to align the simplified gradient with the GIS data. The signal designer must produce all the simplified gradients.

### 5.2.2 Alternative Sources for Gradient Data

There are areas where Sydney Trains' gradient data does not exist. In most cases these areas are outside the ATP project scope.

If a VAD gap is being encountered where TSM is being implemented under ATP, then the signal designer must raise an RFI to TfNSW for assessment and rectification.

TfNSW with consultation from Sydney Trains Survey Office shall decide the final gradient to be used for the gap area and communicate this to the signal designer and data designer.

The signal designer must also record the area and the action taken in the supporting documentation to accompany the signal design submission.

### 5.2.3 Site Verification Requirement for Gradient Data

The gradient data provided by Sydney Trains is the design grade for the tracks. This is the grade the track is constructed and maintained to. As such no further site certification of the gradient data is required.

## 6 Use of Site Certification Form

The SCF contains two sections, Part A used for advising the correct location for balise installation and Part B used for geographical data verification. A blank SCF is provided in Appendix A.

In ATP, the positions to install balises are given as distances from existing assets. These existing assets are referred to as the **Reference Asset** for the balise group.

Balises in ATP are used to communicate specific trackside information, such as Target Speed, display of an ETCS message or other changes coming into effect at a specified location. This location is referred to as the **Target Location** for the balise group. Depending on the ATP function, this location can be hundreds of meters ahead of a balise group to provide enough time/distance for the system to transition from one speed or state to another. This means the Target Location is not always suitable to be the reference for installation of balises.

The maximum allowable distance between the balise group and the reference location used for installing the balise is dependent on the accuracy of measurements. Using a measuring wheel or other such tools should allow for measurements of up to 100m with

an accuracy of +/-2m. Greater distances could be measured while maintaining +/-2m accuracy using more precise tools. The tools used and their precision must be recorded in the SCF by the installer.

Where the distance between the target location and the associated balise group is within 100m, the target location becomes the reference asset. If the Target Location is more than 100m from the balise group, then a separate asset nearest to the balise group within 100m must be identified to be the Reference Asset for that balise group.

If a Target Location is within 100m but it is not related to an existing asset, for example entry/exit to Yard locations or level transition boards, then separate Reference Asset must be selected for that balise group. An acceptable list of existing assets which can be used as Reference Asset is provided in section 6.4.

**A balise group must have only one Reference Asset.**

A balise group can have multiple Target Locations. Where balise groups are used for protecting high risk turnouts, the toe of points either side of the turnout need to be listed as target locations. Balise groups with cascaded functions shall also list all of its target locations including any intermediate speed sign within the TSM. All of these Target Locations will need to be recorded in SCF Part B and site verified, refer to Appendix B for examples of Target Locations for different ATP functions.

The Reference Asset and Target Location will generally differ only for High Risk Speed Signs, High Risk Turnouts and some High Risk Overlap Deficiencies. For High Risk Speed signs the Reference Asset is the speed sign where the BG is placed and the Target Location is the High Risk Speed Sign itself. For High Risk Turnouts / Overlap Deficiencies, the Reference Asset is generally the signal interfacing with the LEU and the Target Location is the actual toe of the points / signal immediately prior to the overlap. For other functions the hazard being protected will generally be close enough to the optimal location for the BG such that it can be used as the reference asset for balise installation. A list of acceptable Reference Assets is provided in section 6.4. The measuring points for Target Locations and Reference Assets and the process of manual measurements are provided in section 7.

The activities shown in Figure 3 are to be carried out by the signal designer, installer and T/C team to complete and update the SCF at different stages. Refer to section 5 for the overall process of use of geographic data for ATP. The activities in Figure 3 are numbered to align with the diagrams in Figure 4 and Appendix B, providing a visual aid

Reference material only

to understand these activities. Appendix B also shows the corresponding entries to the SCF for the different ATP functions.

Note that number (9) in Figure 4 and Appendix B is not mentioned in Figure 3; this is the distance between the two balises in a balise group as mandated in the ASA Signalling Design Principle – ETCS Level 1.

Reference material only

Reference material only

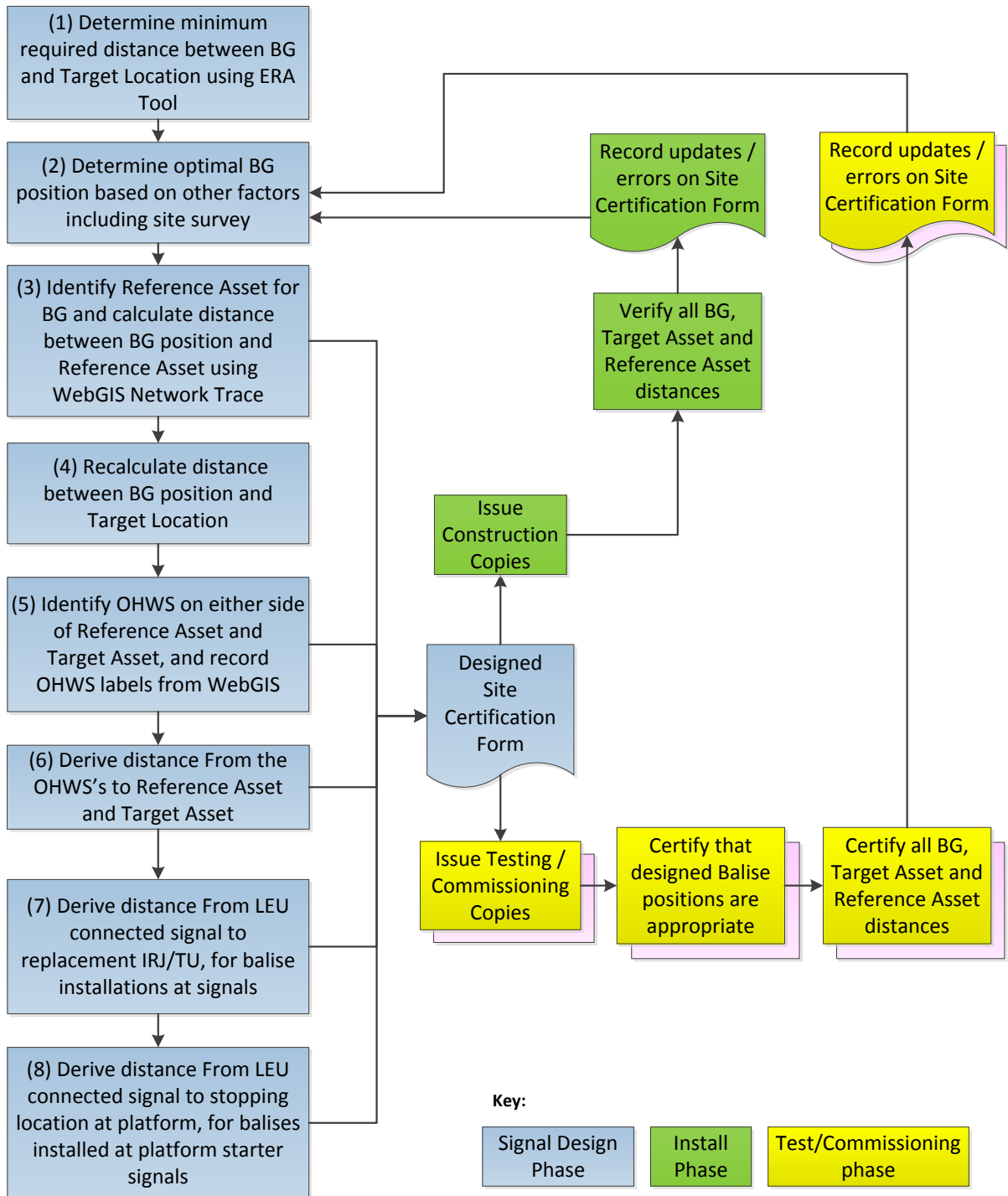
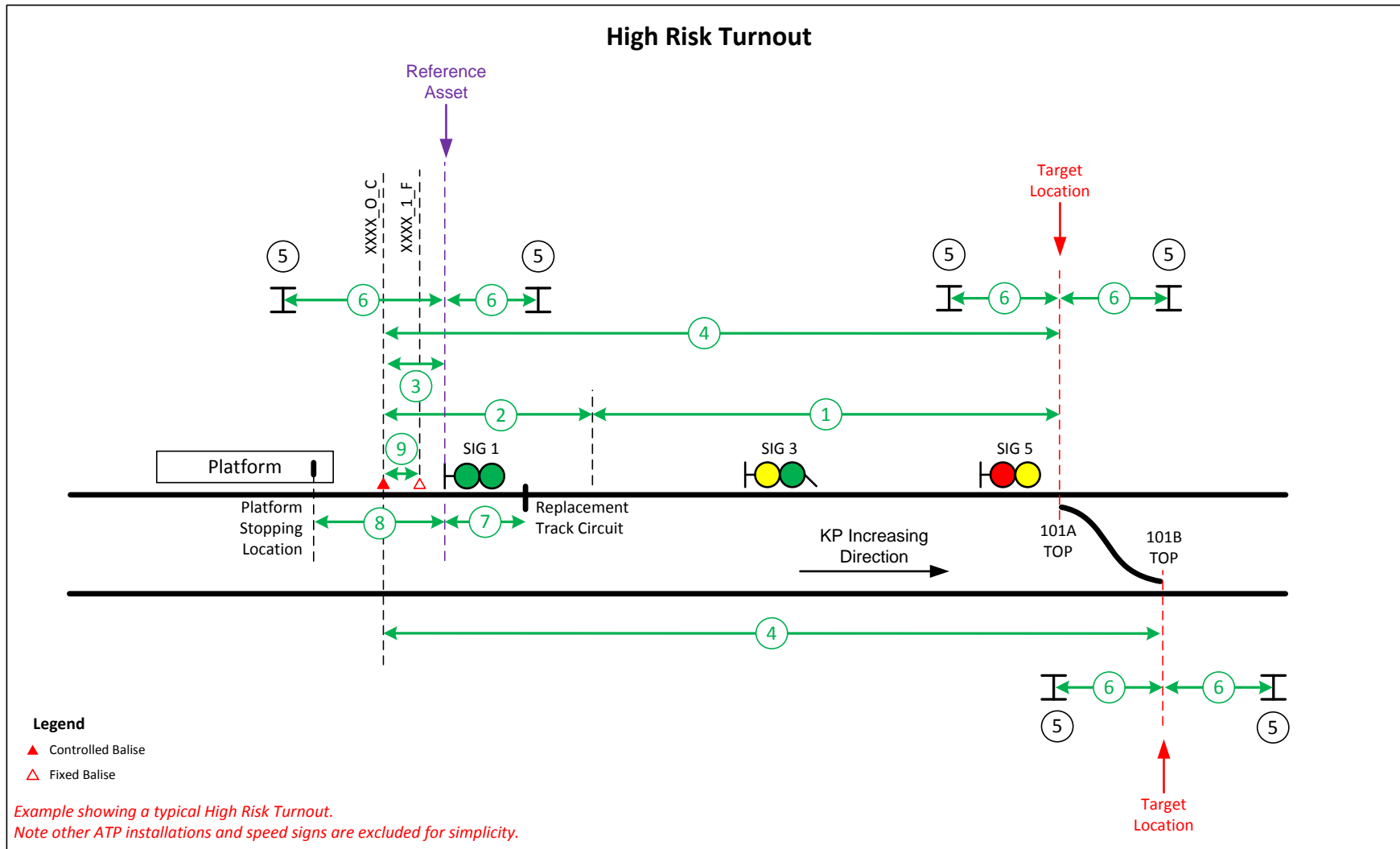

Figure 3: Example activities related to completing and updating SCF at various stages

Reference material only



**Figure 4: Distances the designer needs to measure using Sydney Trains GIS data and record in SCF**

## 6.1 Identifying Balise Position and Locations for Verification

The activities shown in blue in the flowchart given in Figure 3 should be undertaken by the signal designer to identify the intended / optimal position for each balise group, and the necessary site measurements required to verify the Reference Asset and Target Location(s) associated with the balise group.

The signal designer carries out tasks (1) and (2) as shown in the flowchart in Figure 3 to determine the optimal location for a balise group. If the optimal location is within 100m of the hazard being protected by the balise, then this hazard is the Reference Asset as well as the Target Location for the balise group. In this situation, it is sufficient to only populate the Reference Asset fields of SCF for that BG.

If the Target Location is more than 100m from the optimal location for the BG than a separate Reference Asset must be identified and the distance between the balise location and Reference Asset needs to be derived, this is task (3) in Figure 3. In this situation, fields related to both Reference Asset and Target Location will need to be populated in SCF for that BG.

Note that the position of balise group is the position of the first balise in the balise group, this balise is associated with  $N\_PIG = 0$ . Thus the distance between Reference Asset and BG is to be populated in the column corresponding to the balise  $N\_PIG = 0$  in SCF Part A. The next balise in balise group is to be installed within specified distance from the first balise, as per the ASA Signalling Design Principle – ETCS Level 1. The signal designer shall add this specified distance to the distance between Reference Asset and BG to populate the column corresponding to the Balise  $N\_PIG = 1$ . Refer to ATP Project Specification: Trackside Design Guideline for further details on  $N\_PIG$ .

For each Reference Asset and Target Location(s) the signal designer also needs to identify OHWS on both sides, and measure the distances from the Reference Asset/Target Location(s) to the OHWS. These are to be recorded in SCF Part B and used for verification of location data used in ATP design. If a speed sign is used as Reference Asset or Target Location and the speed sign is located on an OHWS, then it is sufficient to enter the OHWS label in the “Sydney Side OHWS Label” of SCF Part B, and to enter a measurement of Zero as associated distance. These are tasks (5) and (6) in Figure 3.

The signal designer must also derive the distances mentioned in tasks (7) & (8) where applicable and record them in SCF Part A.



All distances derived and/or decided by the signal designer must be populated in the 'Design' fields of the SCF. All measurements must be recorded to one decimal place, i.e. to closest 10 centimetres, following nominal mathematical rounding. For example, a measure of 2m 35 cm shall be rounded to 2m 40cm and be recorded as 2.4m in SCF; similarly a measure of 2m 32cm shall be rounded to 2m 30cm and be recorded as 2.3m in SCF. All distances in SCF Part A need to be directional, with a Positive (+) distance indicating going further from Sydney and Negative (-) distance indicating coming closer to Sydney.

The signal designer shall use the 'Site Specific Notes' section of the SCF to record/request any other measurements required to be site verified, e.g. verification of distance to BG from additional assets, where the Reference Asset is more than 100m away from the BG. Refer to section 6.4 for further details on acceptable Reference Assets.

The SCF should be used by the installers to record and verify site measurements in the 'Actual' fields of the SCF and the Tester/Commissioner for certifying the measurements recorded by the installers.

## 6.2 Balise Installation and Site Verification

The activities shown in green in the flowchart in Figure 3 should be undertaken by installers.

The installer shall carry out an initial site audit prior to installation of balises to ascertain that the balise positions and other measurements specified in SCF Part A are achievable. For distance, if it is not possible to install the balises less than +/-2m from their specified designed locations and also adhere to all other specified restrictions, then the signal designer must be consulted to make appropriate changes and reissue the SCF with updated values in the relevant design field of SCF Part A. The installer must also carry out the verification of geographic data at this stage; refer to section 6.3 for further detail of verification of geographic data. Any updates to the SCF must also be provided to the data designer for updating the ETCS data.

The installer must update SCF Part A by populating the 'Actual' fields with distances measured on site given in metres. The rounding rule and use of Positive (+) and Negative (-) signs for distances as per section 6.1 apply.

For the Balise Height (BRM vertical measurement from top of rail) parameter, the installer must populate SCF Part A in the 'Actual' field in metres after the installation of

Reference material only

the direct fixed balise only (Concrete slab or sleeper mounted balise). Measurements must be recorded to three decimal places i.e. to the closest 1 millimetre. For example, a measure of 0.076m (76mm) does not need to be rounded and is to be recorded as 0.076m in SCF. For Vortok Beam mounted balises, mark the field with 'Ve' (for Vortok eClip style), 'Vf' (for Vortok FastClip style) or 'Vu' (for Vortok Universal/Clamp style).

Note that all measurement must be written clearly or typed, to avoid any misinterpretation.

All installation must also comply with other balise placement restrictions mentioned in ASA Signalling Design Principle – ETCS Level 1.

Once the green (Construction) copy of the Site Certification Form has been returned by the installers, it will be issued for either testing (pink copy) or Commissioning (yellow copy), along with the updated circuit books and other testing / commissioning documents.

The activities shown in yellow/pink in the flowchart in Figure 3 should be undertaken by T&C to certify the Balise Group positions. This means only the measurements in SCF Part A need to be certified by the T&C, unless otherwise advised by the ATP Change Management Workgroup. It is sufficient for the T&C to place a tick next to the actual measures in SCF Part A, to denote the measure as certified.

Where distance measurements vary by +/-2m or more from the actual measurements recorded during installations, the SCF must be updated with a line through the old measurement in the actual field and the new measurement recorded next to it. The tester must also check all installations comply with other balise placement restrictions mentioned in ATP Project Specifications; and ASA Signalling Design Principle – ETCS Level 1 and any misalignment needs to be recorded. The updated SCF must be provided to ATP Change Management Workgroup for advising necessary changes in ETCS data or balise locations.

### **6.3 Site Verification of Geographic Location Data**

The installer must check the distances from Reference Assets and Target Locations to OHWS as provided by the signal designer in SCF Part B. This activity is required to be carried out prior to the actual installation of balises to provide the data designer enough time to update ETCS data with the site verified locations if data change is required. The installer must record the actual measurements in meters in SCF Part B. The same rounding rules, as per section 6.1 and 6.2 apply.

Reference material only

The installer may choose to carry out the above activity at the same time as the initial site audit carried out to ascertain the balise locations are achievable.

The updated SCF must be provided to the data designer.

Unless otherwise decided by the ATP Change Management Workgroup, this is the only time verification of geographic location needs to be carried out.

## 6.4 Acceptable Reference Assets

The Reference Asset needs to be identifiable in the input location data and be easy to locate on site. The following assets can be used as a Reference Asset; they are listed in the order of preference.

Note: The Target Location of the BG, given it is within 100m of the BG and relates to one of existing assets mentioned below, must be the Reference Asset for that BG.

- Signals including Fixed Red Signals
- Speed signs (BG naming shall be based on the latest TOC or Signalling Plan)
- Stop Signs
- Buffer stops
- Toe of points (TOP)
- Start of throw rail for catch points
- Km or half Km posts
- End of line<sup>1</sup>
- Level/Pedestrian crossing edge<sup>1</sup>
- Edge of Big Metal Mass (BMM)<sup>1</sup>
- Platform stopping location<sup>1</sup>

OHWS must not be used as Reference Asset since these are used for site verification of input location data.

If the Reference Asset is more than 100 metres away from the balise position, a second, closer infrastructure asset and distance shall be used to check the measurement. A OHWS can be used as the second infrastructure asset. This asset and distance from this asset to the balises shall be recorded in the 'Site Specific Notes' of SCF. The same rounding rule and use of Positive (+) and Negative (-) signs as per section 6.1 apply for these distances. This scenario is expected to be rare and only occur around

---

<sup>1</sup> GIS may not have the exact location for this ATP POI; as such this POI may not appear in the GIS Extract. Aerial photos from WebGIS can be used to measure distance to/from this POI. For example, GIS usually has the mid-point of platforms and not the actual edge of the platform.

Reference material only

announcement, level transition, wrong running protection and/or big metal mass protection balise groups.

Note that a level transition board cannot be a Reference Asset since these are new sign posts being installed by the project. Therefore, announcement and level transition balises will need to have other Reference Assets and the Level Transition Board will need to be placed at distances from these balise groups as mentioned in ASA Signalling Design Principle – ETCS Level 1.

## 7 Site Measurement Process

### 7.1 Measurement Points

This section details the measurement points for balise, OHWS and other existing assets likely to be a Target and/or Reference asset.

#### 7.1.1 General Requirements

For assets with an existing survey pin and/or Track Control Mark (TCM), the survey pin must be used as the measurement point for this asset. For example, the arrow in Figure 5 points to the survey pin associated with an OHWS.



Figure 5: Survey pin located on an Overhead Wiring Structure

In the absence of a survey pin, the vertical centreline of the infrastructure can be regarded as the measurement point for the asset unless otherwise mentioned within this guideline.

The vertical centreline of a Speed Board mounted on an OHWS and a post mounted signal are shown in Figure 6.

Reference material only

Reference material only

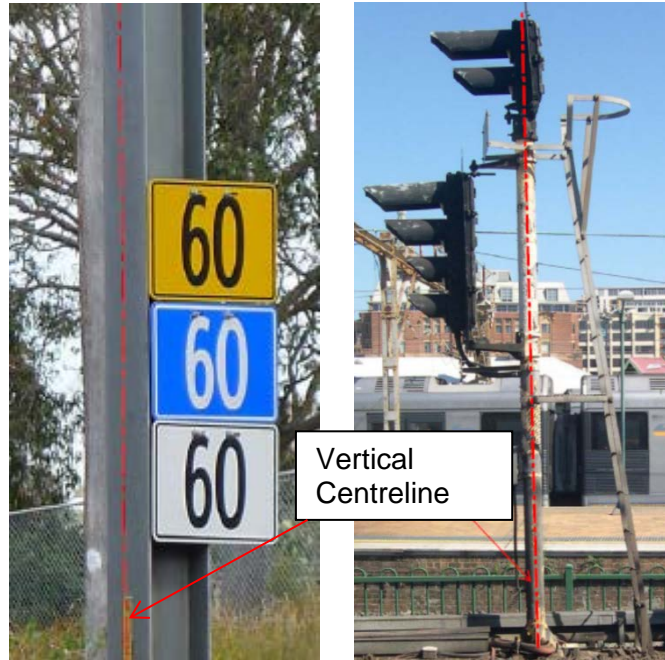

Figure 6: Vertical Centreline of infrastructure

### 7.1.2 Gantry Signals

Gantry signals often have more than one post supporting the gantry structure. Where there are multiple supporting posts, the vertical centreline of the first post encountered in the direction of travel associated with that signal shall be the measurement point for that gantry signal. Refer to Figure 7.

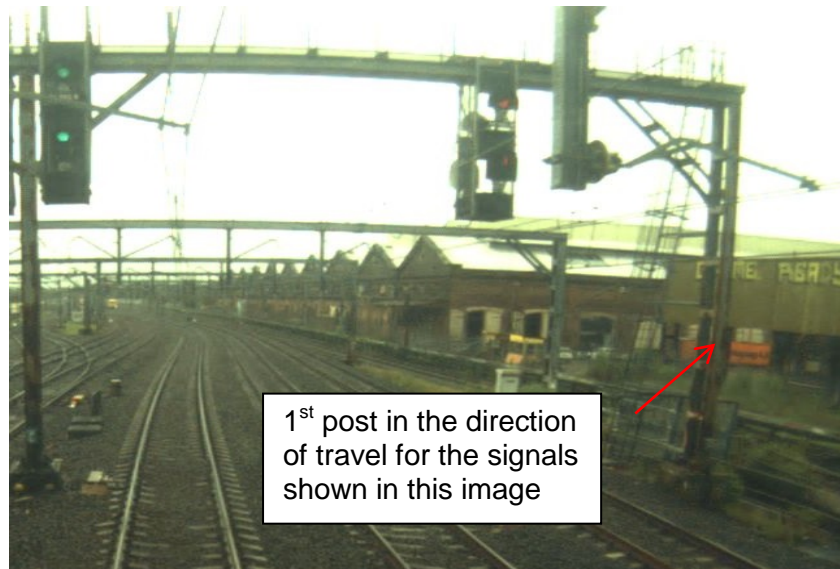

Figure 7: Measurement point for mechanical Trainstop

### 7.1.3 Catch Points

The measurement point for catch points must be the start of the throw-off rail, as shown in Figure 8.

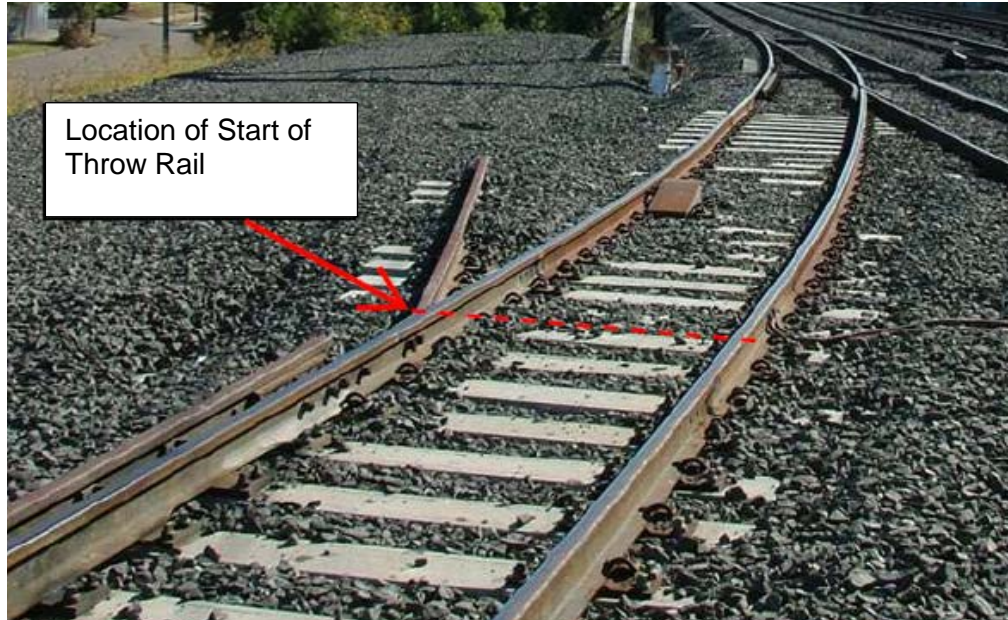

Figure 8: Measurement point for Catch Points

### 7.1.4 Toe of the Points

For the toe of a set of points, the measurement point must be the end of the blade of the switch rail as shown in Figure 9 below.

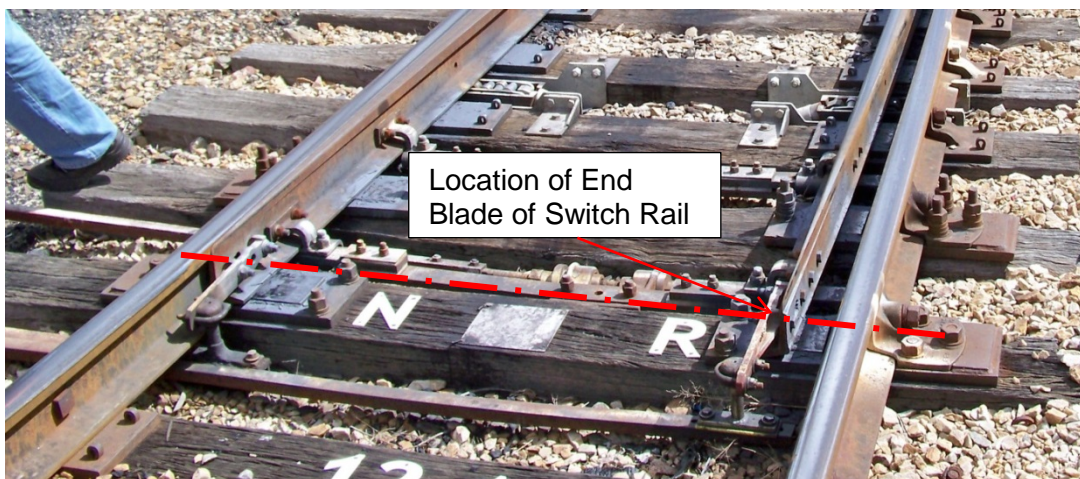

Figure 9: Measurement point for Toe of Points

### 7.1.5 Platform Stopping Locations

Platform car markers indicate the operational stopping location for rolling-stock of various lengths. Where the car markers are painted on the platform, the centre of the car marker is the measurement point for that car marker, as shown in Figure 10.

Reference material only

The vertical centreline of the post must be taken as the measurement point for car markers placed on posts.

Note that some smaller platforms have their car markers located several meters away from the platform itself.

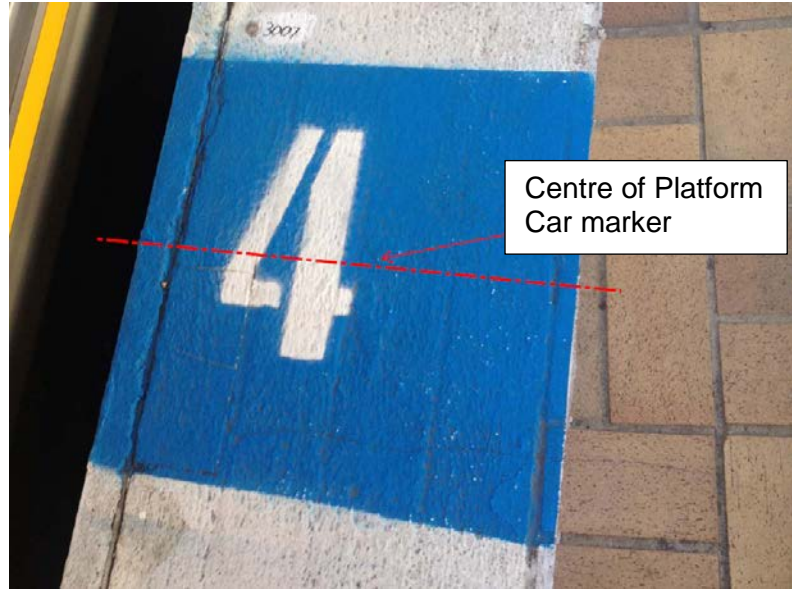

Figure 10: Measurement point for Car Markers painted on Platform

Where there is no platform car marker for a platform, the edge of the platform must be used as the operational stopping location for that platform.

The measurement point for the edge of a platform must be the end point of the usable platform area, i.e. typically the end of platform fence as shown in Figure 11.



Figure 11: Measurement point for Edge of Platforms

Reference material only

### 7.1.6 Track Circuits

For Insulated Rail Joints (IRJs) or Block Joints, the vertical centreline of the joint must be used as the measurement point, as shown in Figure 12.

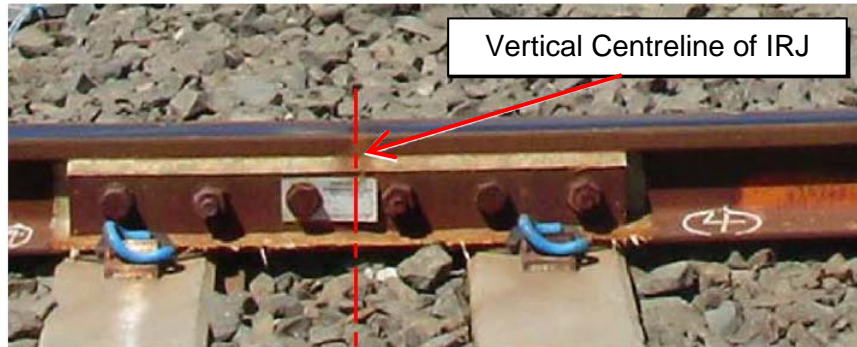

Figure 12: Measurement point for IRJs

For Tuned Loops, the rail connection of the tuning unit closest to the proposed Balise Group position must be used as the measurement point. The rail connection for a tuning unit is shown in Figure 13.

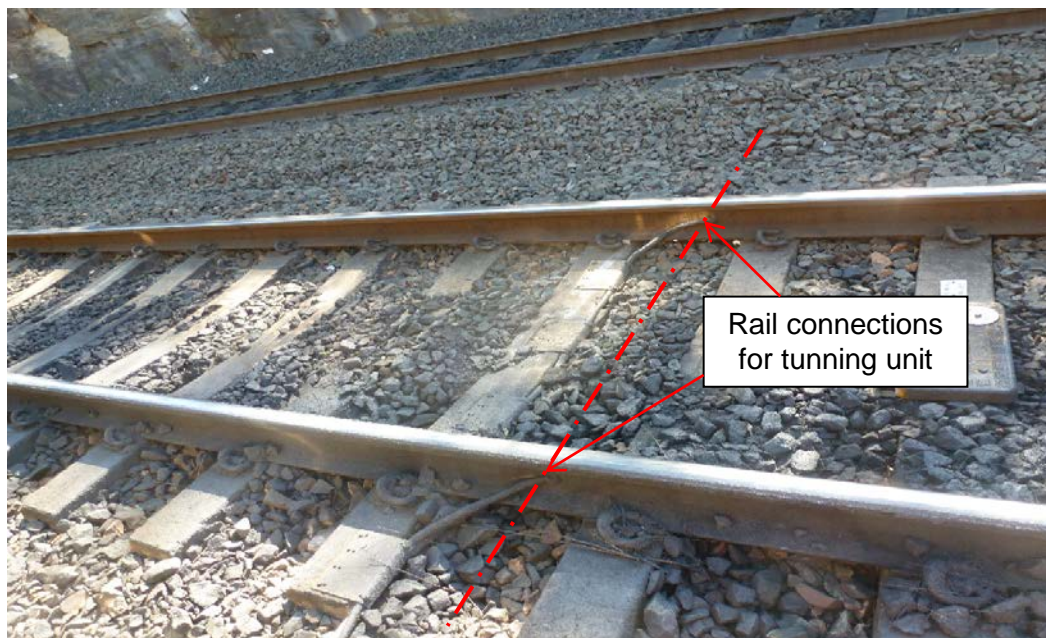

Figure 13: Measurement point for a Tuning Unit

Note that the measurement points mentioned here are not related to the replacement point of track circuit; refer to ASA Signalling Design Principle – ETCS Level 1 for the replacement point of track circuit.

Reference material only



### 7.1.7 Level Crossings

The measurement point for a level crossing is the closest edge of the level crossing in the direction of travel. If the crossing is traversed in both directions, the location of both edges of crossing may need to be captured. These are then to be denoted as the Sydney Side and Country Side edges to differentiate between the two POIs.

The edge of crossing is the point where the road (or walkway) surface meets the rail, as shown in Figure 14.

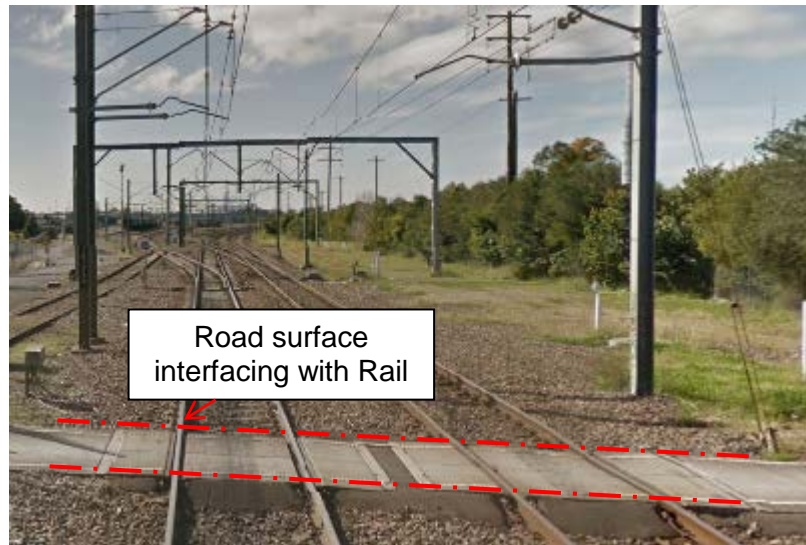

Figure 14: Measurement points for Crossings

Where multiple crossings (pedestrian and/or road crossings) are located side by side, as shown in Figure 15, they are to be treated as one continuous crossing and the two edges at the extremities are to be used as the measurement points.

Reference material only

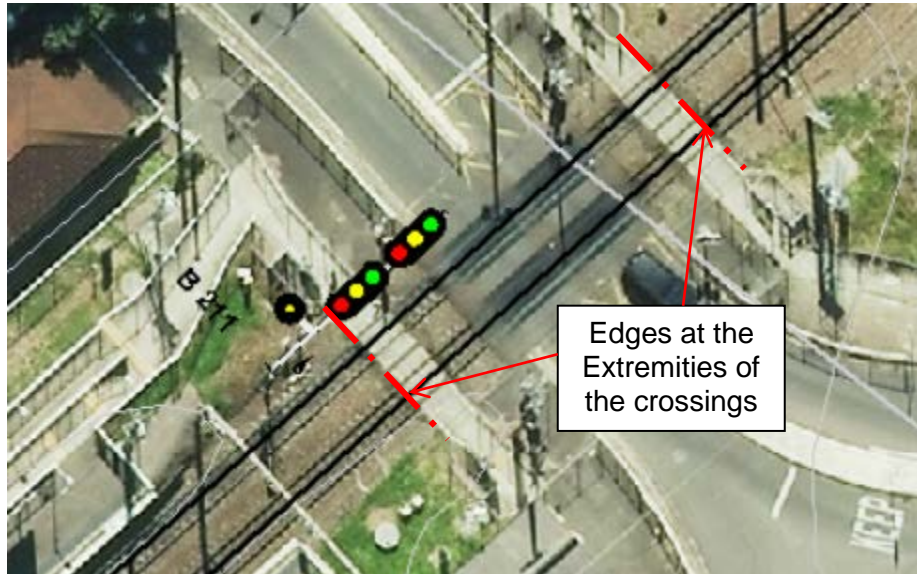

Figure 15: Measurement points for multiple crossings located side by side

### 7.1.8 Balise and Balise Group

The Balise Reference Mark (BRM) as specified by the supplier must be used as the measurement point for individual balises. Figure 16 shows the BRM for an Alstom Balise.

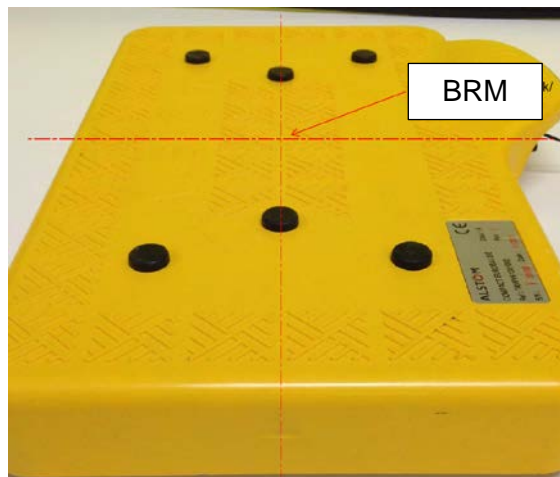

Figure 16: Balise Reference Mark on Alstom Balise

### 7.1.9 Buffer Stops

The measurement point for a buffer stop is the face of the buffer stop, as shown in Figure 17.

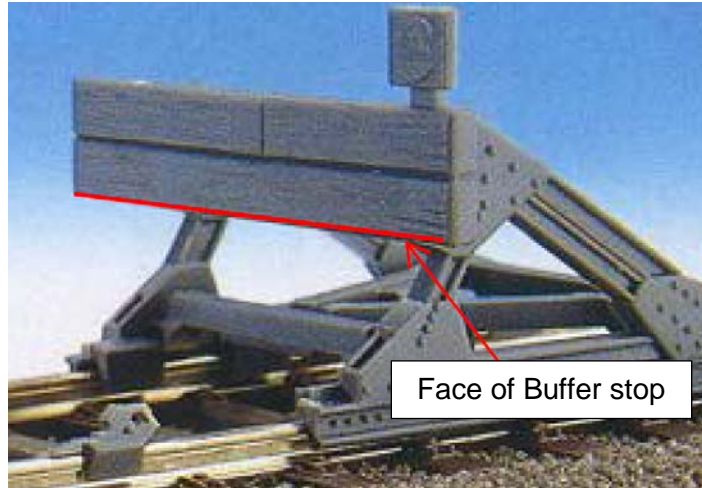

Figure 17: Measurement point for buffer stop

### 7.1.10 End of Line

End of Line refers to the physical end of the track; this is the point up to which rolling-stock can move without derailing, running into dirt or other infrastructures except buffer stops.

Since this location is usually beyond the operational stopping location, it will not be possible to capture data on this location using survey vehicles. As such WebGIS may not always allow for 'Network Trace' up to the end of track.

This location can be approximated from aerial photos using the 'Measure' function of WebGIS or other means as long as a safe approximation is made. For example the measurement point shown in Figure 18 is the middle of the third last sleeper of the track as shown with the dotted line. This is a safe approximation for the end of track shown in the solid line. All approximations made need to be noted as 'Site Specific Notes' in SCF, since the same measuring point will need to be used on site.

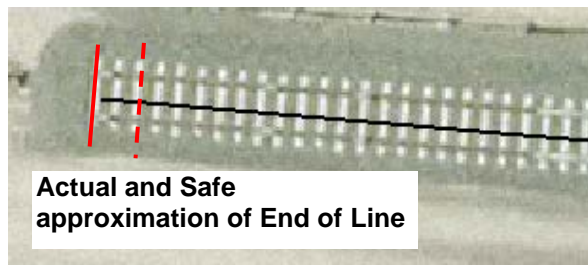

Figure 18: Example measurement point for End of Line

### 7.1.11 Big Metal Masses

Big Metal Masses are infrastructure containing metal that may affect the ability of an ATP fitted train to read a Balise. BMMs must be recorded for both ETCS Level '0' (not

fitted with ATP) and ETCS Level '1' (fitted with ATP) areas. Refer to EGG 1656 – Balise Placement and Metal Mass Assessment Guide for details on what constitutes a BMM and what parameters are required to be captured in addition to its geographical location.

The measurement points for BMMs are determined by the type of asset it is. For example, if a level crossing is considered as a BMM, the measurement point for crossings as described in section 7.1.7 will apply.

If the asset is not exclusively described in this guideline, the measurement points are the two edges of the asset interacting with the rail surface and/or parallel to sleepers. These are to be denoted as the Sydney Side and Country Side edges.

## 7.2 Measurement Tools

The tools to be used for the measurement of geographic data for ATP must satisfy the following:

- The tools must not interfere with the signalling system, e.g. short-circuit track circuits
- The tools used must be safe to be used within the vicinity of the 1500V DC overhead wires
- The tools, along with the process must be able to measure up to a distance of 100m with an accuracy of +/-2m
- The tool(s) used, it's precision and calibration date (if applicable) must be recorded in the SCF.

## 7.3 Measurement Procedure

The procedure below details the steps for measuring distances to mark and/or install balises and to site verify Reference Asset and Target Location(s) associated with the BG. The tester/certifier of the BG can follow the procedure for measuring distances mentioned in SCF part A and 'Site Specific Notes'.

The following procedure must be used in conjunction with the Site Certification Form provided in Appendix A. Figure 19 gives a visual indication of the process. The numbers shown in Figure 19 refers to the numbered activities mentioned in Figure 3.

Reference material only

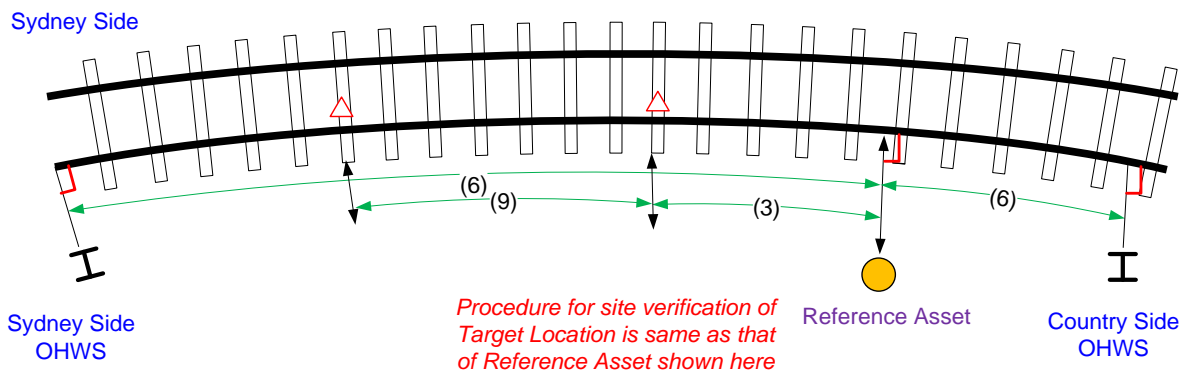

**Figure 19: Measurement Procedure for ATP**

1. Identify the Reference Asset on site and identify the measurement point on the asset as detailed in section 7. Mark the measurement point if required to maintain accuracy of the measurements.
2. Identify the location perpendicular to the measurement points on the nearest rail of the designated track (the track associated with the Reference) as shown in Figure 19. Mark the position of the rail if required to maintain accuracy of measurement.
3. Measure out the distance from the Reference Asset to the balises in the balise group as specified in the SCF Part A.
4. If the distance falls in between two sleepers, identify the nearest sleeper suitable to install the balises (where applicable).  
 Various mounting options exists for installation of balises, both on sleeper and between sleepers; refer to SPG 0706 Installation of Trackside Equipment for further information.  
 Ensure the balises meet all restrictions applicable, as specified in ASA Signalling Design Principle – ETCS Level 1.
5. Mark the balise locations and/or install the balises and update SCF Part A accordingly. When marking the balise locations use appropriate marking equipment to mark both the sleeper (where applicable) and the side of the rail.

Note that the steps 6 to 10 are for site verification of Reference Assets and Target Locations only and related to SCF Part B. Generally they would only be carried out at the same time as marking the balise locations, refer to section 6.3 for further information.

Reference material only

6. Identify the OHWSs associated with the Reference Asset as described in the Site Certification form and identify the measurement points for these as detailed in section 7. Identify the location perpendicular to the measurement points on the nearest rail of the designated track.
7. Measure and Record distances between the Reference Asset and the OHWSs associated with it in the actual field in SCF Part B.
8. Identify all Target Location(s) associated with the BG and identify their measurement points as detailed in section 7. Identify the location perpendicular to the measurement points on the nearest rail of the designated track.
9. Identify the OHWSs associated with the Target Location(s) as described in the Site Certification form and identify the measurement points for these as detailed in section 7. Identify the location perpendicular to the measurement points on the nearest rail of the designated track.
10. Measure and Record distances between the Target Location(s) and the OHWSs associated with it in the actual field in SCF Part B.

## 8 ATP Change Management Workgroup

The purpose of the ATP Change Management Workgroup is to analyse any changes occurring after the marking of balise location and/or verification of location data, and make decisions on subsequent changes. Depending on this decision, the signal designer, site installer and/or data designer may need to revisit activities described in this guideline.

These changes may relate to the installer not being able to install the balises in their previously marked locations. Other concurrent projects may also change the configuration of the infrastructure, including a change to the location of existing assets and/or change in vertical alignment of the track. The latter can lead to changes in location of Reference Assets and/or Target Locations used in ATP. The ATP Change Management Workgroup need to analyse these changes and their impact on ATP functions implemented in the area in order to decide on one or more of the following;

- Change ATP design including relocation, removal and/or inclusion of balises.
- Change ETCS data.
- Repeat site verification, SCF Part B for specific area.

This Workgroup must have representation from signal design, installation/testing, data design, safety assurance and project delivery teams.

Reference material only

The workgroup must set up the necessary interfaces with Sydney Trains and/or other interacting projects to be notified of any infrastructure changes.

The Workgroup must consider the following in making their decision:

- The safety aspect of the decision
- The cost of rework including its impact on project schedule
- The maintainability of the changes resulting from the decision

Following the decision of the Workgroup, the appropriate group (signal designer, site installer and/or data designer) must be engaged for re-work.

The decision of the workgroup must be minuted and form part of the ATP Commissioning Work Pack.

## **9 Record of Geographic Data for Maintenance**

Sydney Trains is responsible for operating and maintaining ATP and will need to maintain the correctness of the geographical data once it is handed over.

Geographical Data must be communicated to Sydney Trains at various stages of the ATP project delivery as per approved Asset Information Delivery Form (AIDF) for the ATP project.

To reduce overload of information and subsequent processing required by Sydney Trains,

The certified SCF after Testing or commissioning of the balises shall be communicated to Sydney Trains GIS Unit in pdf and excel format. This shall also include any revised verification of geographical data conducted by the project.

Sydney Trains GIS is expected to use the SCF Part A for confirming/updating the balise locations in their database and SCF Part B for correcting/updating existing locations as required. The balise locations are expected to be available from GIS including WebGIS shortly after this.

The SCF must also be recorded as part of ATP Commissioning Work Pack and included in the circuit book at as-built stage.

Reference material only





Site Certification Form (ETCS Balise) - CB XXX

General Notes:

- [A] - Target Location refers to the location where the target speed or ETCS message from the associated BG comes into affect. It varies depending on the AMS function being implemented.
- [B] - A Reference Asset is an existing asset. Balise group locations are given as distance from this asset to the first balise in the balise group.
- [C] - This information is only required where the Balise Group is placed directly at the foot of the signal interfacing with LEU.
- [D] - This information is only required where the Balise Group is placed directly at the foot of the signal interfacing with LEU, and this signal is a platform starter signal or a fixed BG at the platform used for mode change.
- [E] - If a speed sign is located on an OHWS, then recording the OHWS label on the "Sydney Side OHWS Label" and a distance of 0m to this OHWS in Part B - Geographical Data Verification section is sufficient
- [F] - Signalling Tester/commissioner will only need to check/verify Part A - Balise Installation/Test & Commissioning section of this form
- [G] - Signalling Tester/commissioner shall place a tick next to the measurements given in the actual fields to check/verify Part A of SCF
- [H] - All distances in Part A need to be directional, with a Positive (+) distance indicating going further from Sydney and Negative (-) distance indicating coming closer to Sydney.
- [I] - At Balise Height column, record measured height for direct fixed balise only (Concrete slab or sleeper mounted balise). Where Vortok Beam fitted, mark cell with: Ve (for Vortok eClip style), Vf (for Vortok FastClip style), Vu (for Vortok Universal/Clamp style).
- [J] - Tolerance for balise height column measurement is +-1mm.
- [K] - Abbreviations: Balise Reference Mark (BRM). Top of Rail (TOR).

Site Specific Notes:

| Part A - Balise Installation/Test & Commissioning |                             |                             |                                   |        |                     |        |  |        |                                  |        | Part B - Geographical Data Verification      |                                     |  |        |                         |  |        |                        |  |        |                         |  |        |
|---|-----------------------------|-----------------------------|-----------------------------------|--------|---------------------|--------|--|--------|----------------------------------|--------|--|-------------------------------------|--|--------|-------------------------|--|--------|------------------------|--|--------|-------------------------|--|--------|
| Measuring Tool:                                   |                             |                             |                                   |        |                     |        |  |        |                                  |        | Measuring Tool:                              |                                     |  |        |                         |  |        |                        |  |        |                         |  |        |
| Accuracy of Tool (for measuring up to 100m):      |                             |                             |                                   |        |                     |        |  |        |                                  |        | Accuracy of Tool (for measuring up to 100m): |                                     |  |        |                         |  |        |                        |  |        |                         |  |        |
| Calibration Date (if applicable):                 |                             |                             |                                   |        |                     |        |  |        |                                  |        | Calibration Date (if applicable):            |                                     |  |        |                         |  |        |                        |  |        |                         |  |        |
| Measurement Date:                                 |                             |                             |                                   |        |                     |        |  |        |                                  |        | Measurement Date:                            |                                     |  |        |                         |  |        |                        |  |        |                         |  |        |
| Balise Group ID                                   | Target Location Name/ID [A] | Reference Asset Name/ID [B] | Distance from Reference Asset (m) |        |                     |        | Distance (m) from LEU Interface Signal |        |                                  |        | Balise Height<br>BRM from TOR                | Verification of Target Location [A] |  |        |                         | Verification of Reference Asset [B]          |        |                        |  |        |                         |  |        |
|   |                             |                             | to Balise N_PIG = 0               |        | to Balise N_PIG = 1 |        | to replacement IRJ/TU [C]              |        | to stop location at platform [D] |        |  | Sydney Side OHWS Label              | Distance (m) from Target Location to SS OHWS |        | Country Side OHWS Label | Distance (m) from Target Location to CS OHWS |        | Sydney Side OHWS Label | Distance (m) from Reference Asset to SS OHWS |        | Country Side OHWS Label | Distance (m) from Reference Asset to CS OHWS |        |
|   |                             |                             | Design                            | Actual | Design              | Actual | Design                                 | Actual | Design                           | Actual |  | Actual                              | Design                                       | Actual | Design                  | Actual                                       | Design | Actual                 | Design                                       | Actual | Design                  | Actual                                       | Design |
|   |                             |                             |                                   |        |                     |        |  |        |                                  |        |  |                                     |  |        |                         |  |        |                        |  |        |                         |  |        |
|   |                             |                             |                                   |        |                     |        |  |        |                                  |        |  |                                     |  |        |                         |  |        |                        |  |        |                         |  |        |
|   |                             |                             |                                   |        |                     |        |  |        |                                  |        |  |                                     |  |        |                         |  |        |                        |  |        |                         |  |        |
|   |                             |                             |                                   |        |                     |        |  |        |                                  |        |  |                                     |  |        |                         |  |        |                        |  |        |                         |  |        |

Reference material only

## Appendix B. Reference Assets and Target Locations for Different ATP Functions

The Target Location and Reference Assets related to various ATP function and required entries by the designer on the Site Certification Form are shown given below. The numbers ((3) to (9) that appear in the extract of Site Certification Form below, correlate to the numbered activities in Figure 3 of this document.

Reference material only

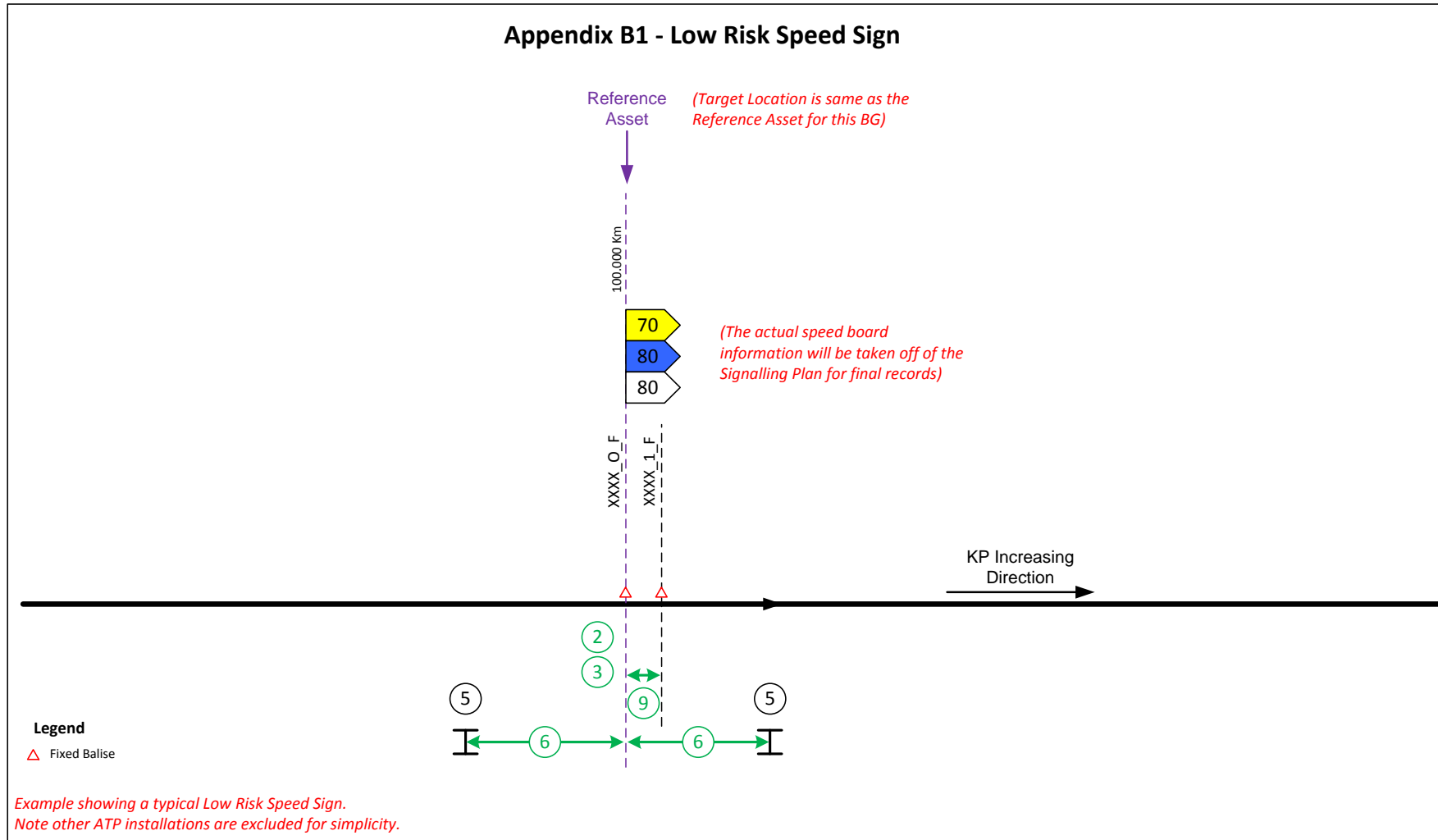

Note: Only the applicable rows/columns in the SCF below are shown for this example.

| Balise Group ID | Target Location Name/ID [A] | Reference Asset Name/ID [B] | Distance from Reference Asset (m) |        | Distance (m) from LEU Interface Signal |        |                           |        | Verification of Target Location [A] |        |                        |  | Verification of Reference Asset [B] |  |                        |  |                         |  |        |  |
|-----------------|-----------------------------|-----------------------------|-----------------------------------|--------|--|--------|---------------------------|--------|-------------------------------------|--------|------------------------|--|-------------------------------------|--|------------------------|--|-------------------------|--|--------|--|
|                 |                             |                             | to Balise N_PIG = 0               |        | to Balise N_PIG = 1                    |        | to replacement IRJ/TU [C] |        | to stop location at platform [D]    |        | Sydney Side OHWS Label | Distance (m) from Target Location to SS OHWS | Country Side OHWS Label             | Distance (m) from Target Location to CS OHWS | Sydney Side OHWS Label | Distance (m) from Reference Asset to SS OHWS | Country Side OHWS Label | Distance (m) from Reference Asset to CS OHWS |        |  |
|                 |                             |                             | Design                            | Actual | Design                                 | Actual | Design                    | Actual | Design                              | Actual |                        | Design                                       | Actual                              |  | Design                 | Actual                                       |                         | Design                                       | Actual |  |
| XXXX            | Same as Ref. Asset          | 100.000km 70-80-80          | (3)                               |        | (3)+(9)                                |        |                           |        |                                     |        |                        |  |                                     |  | (5)                    | (6)  |                         | (5)  | (6)    |  |

Reference material only

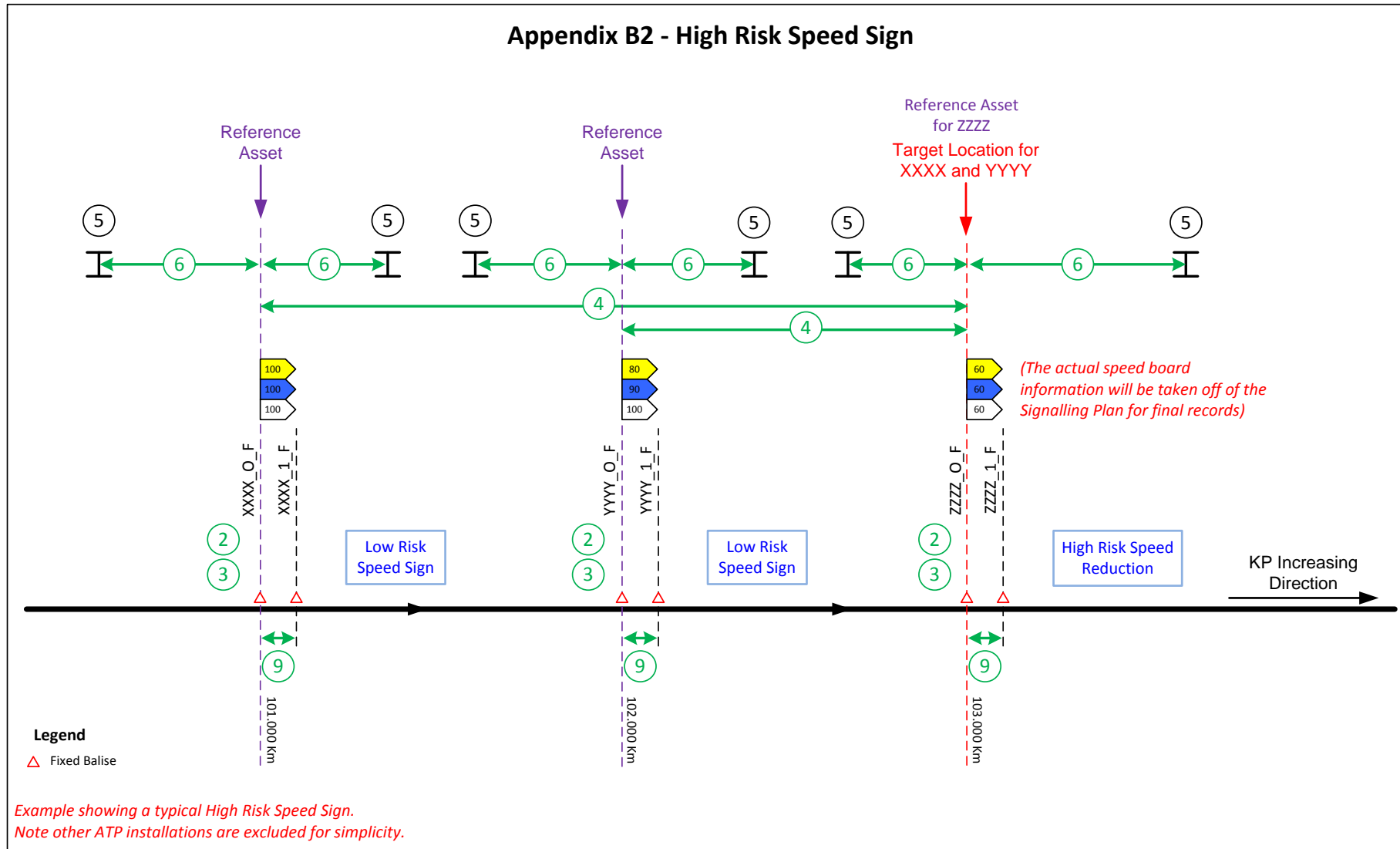

Note: Only the applicable rows/columns in the SCF below are shown for this example.

**Site Specific Notes:**  
# Same as Target Asset for BG XXXX & YYYY

| Part A - Balise Installation/Test & Commissioning |                             |                             |                                   |        |                     |        |  |        |                                  | Part B - Geographical Data Verification      |                                     |  |                         |  |                        |  |                         |  |        |        |
|---|-----------------------------|-----------------------------|-----------------------------------|--------|---------------------|--------|--|--------|----------------------------------|--|-------------------------------------|--|-------------------------|--|------------------------|--|-------------------------|--|--------|--------|
| Measuring Tool:                                   |                             |                             |                                   |        |                     |        |  |        |                                  | Measuring Tool:                              |                                     |  |                         |  |                        |  |                         |  |        |        |
| Accuracy of Tool (for measuring up to 100m):      |                             |                             |                                   |        |                     |        |  |        |                                  | Accuracy of Tool (for measuring up to 100m): |                                     |  |                         |  |                        |  |                         |  |        |        |
| Calibration Date (if applicable):                 |                             |                             |                                   |        |                     |        |  |        |                                  | Calibration Date (if applicable):            |                                     |  |                         |  |                        |  |                         |  |        |        |
| Measurement Date:                                 |                             |                             |                                   |        |                     |        |  |        |                                  | Measurement Date:                            |                                     |  |                         |  |                        |  |                         |  |        |        |
| Balise Group ID                                   | Target Location Name/ID [A] | Reference Asset Name/ID [B] | Distance from Reference Asset (m) |        |                     |        | Distance (m) from LEU Interface Signal |        |                                  |  | Verification of Target Location [A] |  |                         |  |                        | Verification of Reference Asset [B]          |                         |  |        |        |
|   |                             |                             | to Balise N_PIG = 0               |        | to Balise N_PIG = 1 |        | to replacement IRJ/TU [C]              |        | to stop location at platform [D] |  | Sydney Side OHWS Label              | Distance (m) from Target Location to SS OHWS | Country Side OHWS Label | Distance (m) from Target Location to CS OHWS | Sydney Side OHWS Label | Distance (m) from Reference Asset to SS OHWS | Country Side OHWS Label | Distance (m) from Reference Asset to CS OHWS |        |        |
|   |                             |                             | Design                            | Actual | Design              | Actual | Design                                 | Actual | Design                           | Actual                                       |                                     |  |                         |  |                        |  |                         |  | Design | Actual |
| XXXX  | 103.000km<br>60-60-60       | 101.000km<br>100-100-100    | (3)                               |        | (3)+(9)             |        |  |        |                                  |  | (5)                                 | (6)  |                         | (5)  | (6)                    |  | (5)                     | (6)  |        |        |
| YYYY  | same as BG XXXX             | 102.000km<br>80-90-100      | (3)                               |        | (3)+(9)             |        |  |        |                                  |  |                                     |  |                         |  | (5)                    | (6)  |                         | (5)  | (6)    |        |
| ZZZZ  | Same as Ref. Asset          | 103.000km<br>60-60-60       | (3)                               |        | (3)+(9)             |        |  |        |                                  |  |                                     |  |                         |  | #                      | #  |                         | #  | #      |        |

Reference material only

Appendix B3 - ETCS Train Stop

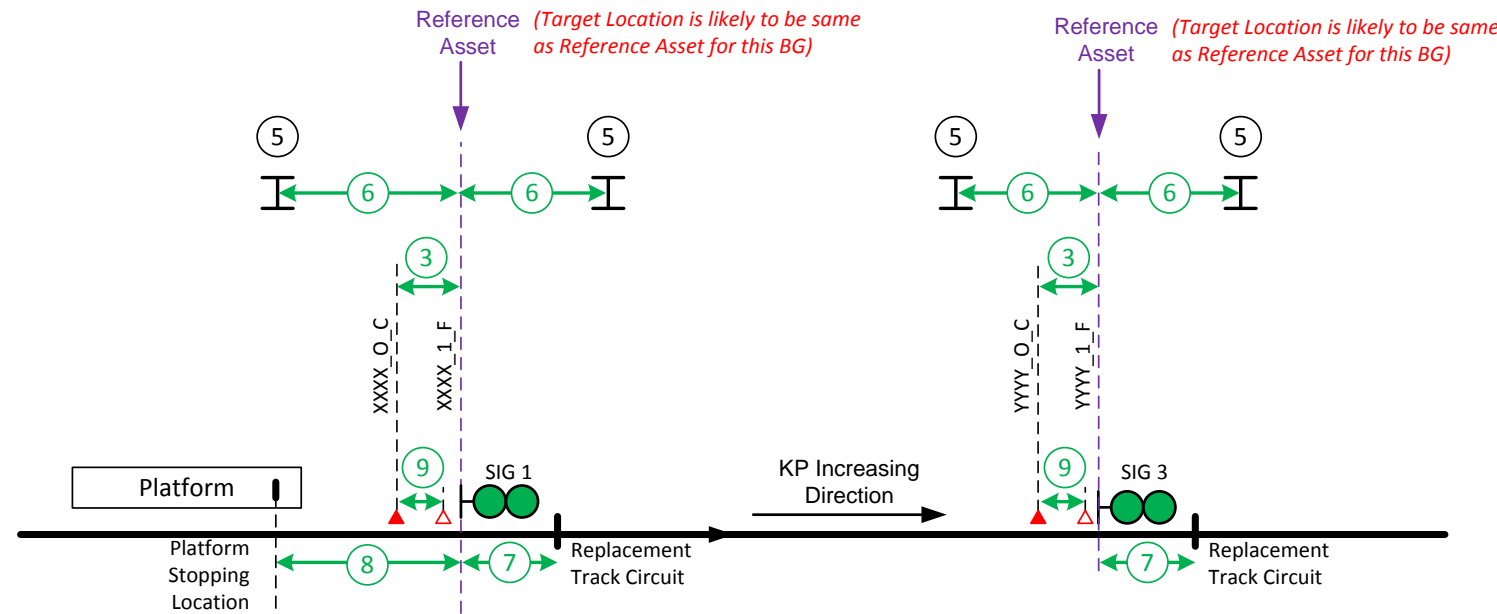

- Legend**
- ▲ Controlled Balise
  - △ Fixed Balise

Example showing a typical ETCS Train Stop.  
Note other ATP installations and speed signs are excluded for simplicity.

Note: Only the applicable rows/columns in the SCF below are shown for this example.

| Balise Group ID | Target Location Name/ID [A] | Reference Asset Name/ID [B] | Distance from Reference Asset (m) |        | Distance (m) from LEU Interface Signal |        |                           |        | Verification of Target Location [A] |        |                        |  | Verification of Reference Asset [B] |  |                        |  |                         |  |        |  |
|-----------------|-----------------------------|-----------------------------|-----------------------------------|--------|--|--------|---------------------------|--------|-------------------------------------|--------|------------------------|--|-------------------------------------|--|------------------------|--|-------------------------|--|--------|--|
|                 |                             |                             | to Balise N_PIG = 0               |        | to Balise N_PIG = 1                    |        | to replacement IRJ/TU [C] |        | to stop location at platform [D]    |        | Sydney Side OHWS Label | Distance (m) from Target Location to SS OHWS | Country Side OHWS Label             | Distance (m) from Target Location to CS OHWS | Sydney Side OHWS Label | Distance (m) from Reference Asset to SS OHWS | Country Side OHWS Label | Distance (m) from Reference Asset to CS OHWS |        |  |
|                 |                             |                             | Design                            | Actual | Design                                 | Actual | Design                    | Actual | Design                              | Actual |                        | Design                                       | Actual                              |  | Design                 | Actual                                       |                         | Design                                       | Actual |  |
| XXXX            | Same as Ref. Asset          | SIG 1                       | (3)                               |        | (3)+(9)                                |        | (7)                       |        | (8)                                 |        |                        |  |                                     |  | (5)                    | (6)  |                         | (5)  | (6)    |  |
| YYYY            | Same as Ref. Asset          | SIG 3                       | (3)                               |        | (3)+(9)                                |        | (7)                       |        |                                     |        |                        |  |                                     | (5)  | (6)                    |  | (5)                     | (6)  |        |  |

Reference material only

Appendix B4 - Buffer Stops

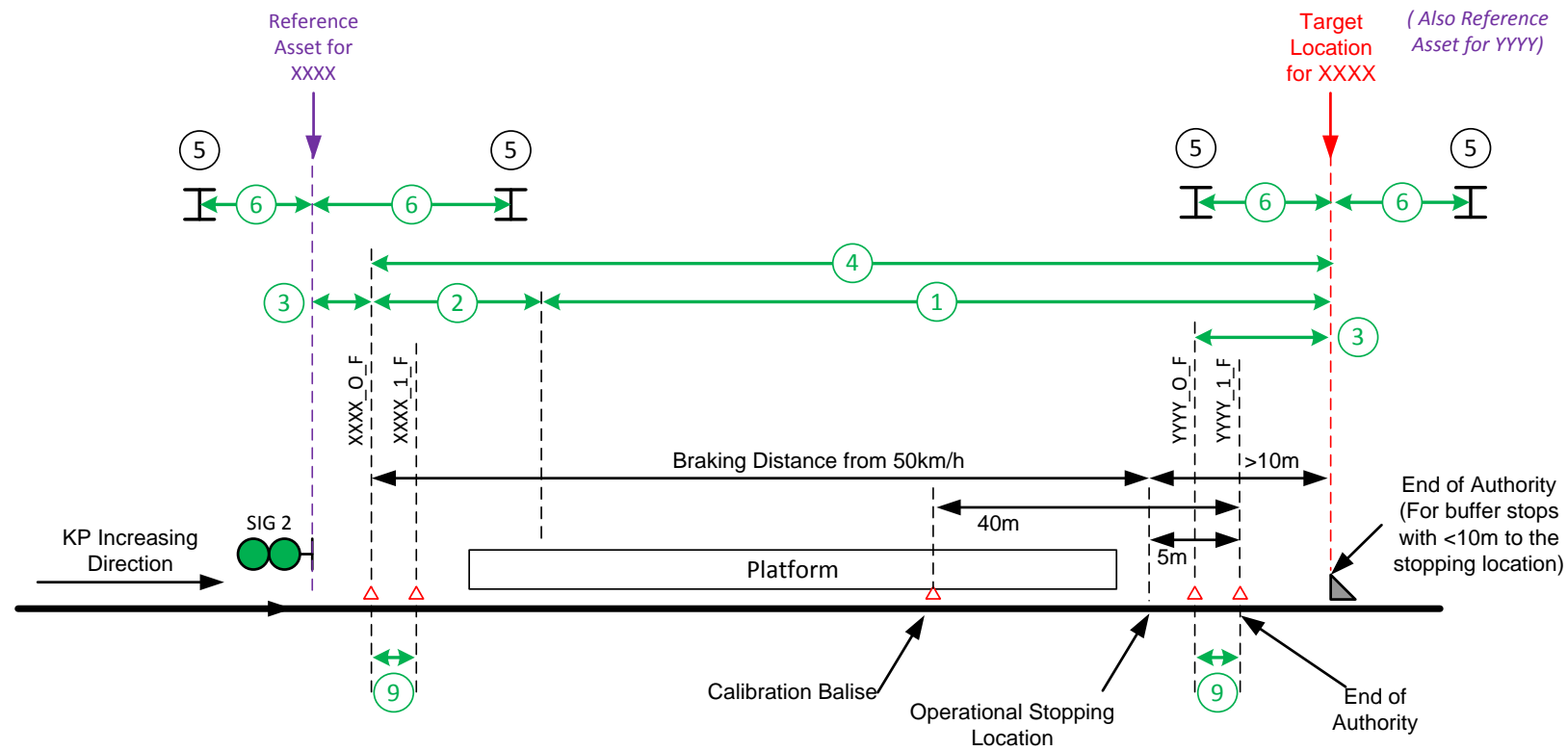

**Legend**  
△ Fixed Balise

*Example showing a typical Buffer Stop where overrun and setting back are possible.  
Note other ATP installations are excluded for simplicity.*

Note: Only the applicable rows/columns in the SCF below are shown for this example.

Reference material only

Site Specific Notes:

1. Record the distance between the buffer stop and the operational stopping point here;
2. For Buffer Stops with the distance >10m to the operational stopping point, record the distance between the operational stopping point and YYYY\_1\_F here;
3. Record the distance of the calibration balise to EoA here;
4. YYYY can be a single balise for buffer stops with the distance <10m to the operational stopping point

# same as Target Location for BG XXXX

| Part A - Balise Installation/Test & Commissioning |                             |                             |                                   |        |                     |        |  |        |                                  |        | Part B - Geographical Data Verification      |                                     |                        |  |        |                         |  |                                     |                        |                                      |        |                         |                                      |        |
|---|-----------------------------|-----------------------------|-----------------------------------|--------|---------------------|--------|--|--------|----------------------------------|--------|--|-------------------------------------|------------------------|--|--------|-------------------------|--|-------------------------------------|------------------------|--------------------------------------|--------|-------------------------|--------------------------------------|--------|
| Measuring Tool:                                   |                             |                             |                                   |        |                     |        |  |        |                                  |        | Measuring Tool:                              |                                     |                        |  |        |                         |  |                                     |                        |                                      |        |                         |                                      |        |
| Accuracy of Tool (for measuring up to 100m):      |                             |                             |                                   |        |                     |        |  |        |                                  |        | Accuracy of Tool (for measuring up to 100m): |                                     |                        |  |        |                         |  |                                     |                        |                                      |        |                         |                                      |        |
| Calibration Date (if applicable):                 |                             |                             |                                   |        |                     |        |  |        |                                  |        | Calibration Date (if applicable):            |                                     |                        |  |        |                         |  |                                     |                        |                                      |        |                         |                                      |        |
| Measurement Date:                                 |                             |                             |                                   |        |                     |        |  |        |                                  |        | Measurement Date:                            |                                     |                        |  |        |                         |  |                                     |                        |                                      |        |                         |                                      |        |
| Balise Group ID                                   | Target Location Name/ID [A] | Reference Asset Name/ID [B] | Distance from Reference Asset (m) |        |                     |        | Distance (m) from LEU Interface Signal |        |                                  |        | Balise Height                                | Verification of Target Location [A] |                        |  |        |                         |  | Verification of Reference Asset [B] |                        |                                      |        |                         |                                      |        |
|   |                             |                             | to Balise N_PIG = 0               |        | to Balise N_PIG = 1 |        | to replacement IRJ/TU [C]              |        | to stop location at platform [D] |        |  | BRM from TOR                        | Sydney Side OHWS Label | Distance (m) from Target Location to SS OHWS |        | Country Side OHWS Label | Distance (m) from Target Location to CS OHWS |                                     | Sydney Side OHWS Label | Distance (m) from Reference Asset to |        | Country Side OHWS Label | Distance (m) from Reference Asset to |        |
|   |                             |                             | Design                            | Actual | Design              | Actual | Design                                 | Actual | Design                           | Actual |  |                                     |                        | Actual                                       | Design |                         | Actual                                       | Design                              |                        | Actual                               | Design |                         | Actual                               | Design |
| XXXX  | Buffer Stop                 | SIG2                        | (3)                               |        | (3)+(9)             |        |  |        |                                  |        |  | (5)                                 | (6)                    |  | (5)    | (6)                     |  | (5)                                 | (6)                    |                                      | (5)    | (6)                     |                                      |        |
| YYYY  | Same as Ref Asset           | Buffer Stop                 | (3)                               |        | (3)+(9)             |        |  |        |                                  |        |  |                                     |                        |  |        |                         |  | #                                   | #                      |                                      | #      | #                       |                                      |        |

Reference material only

Appendix B5 - Wrong Running Hazard (Level Crossing)

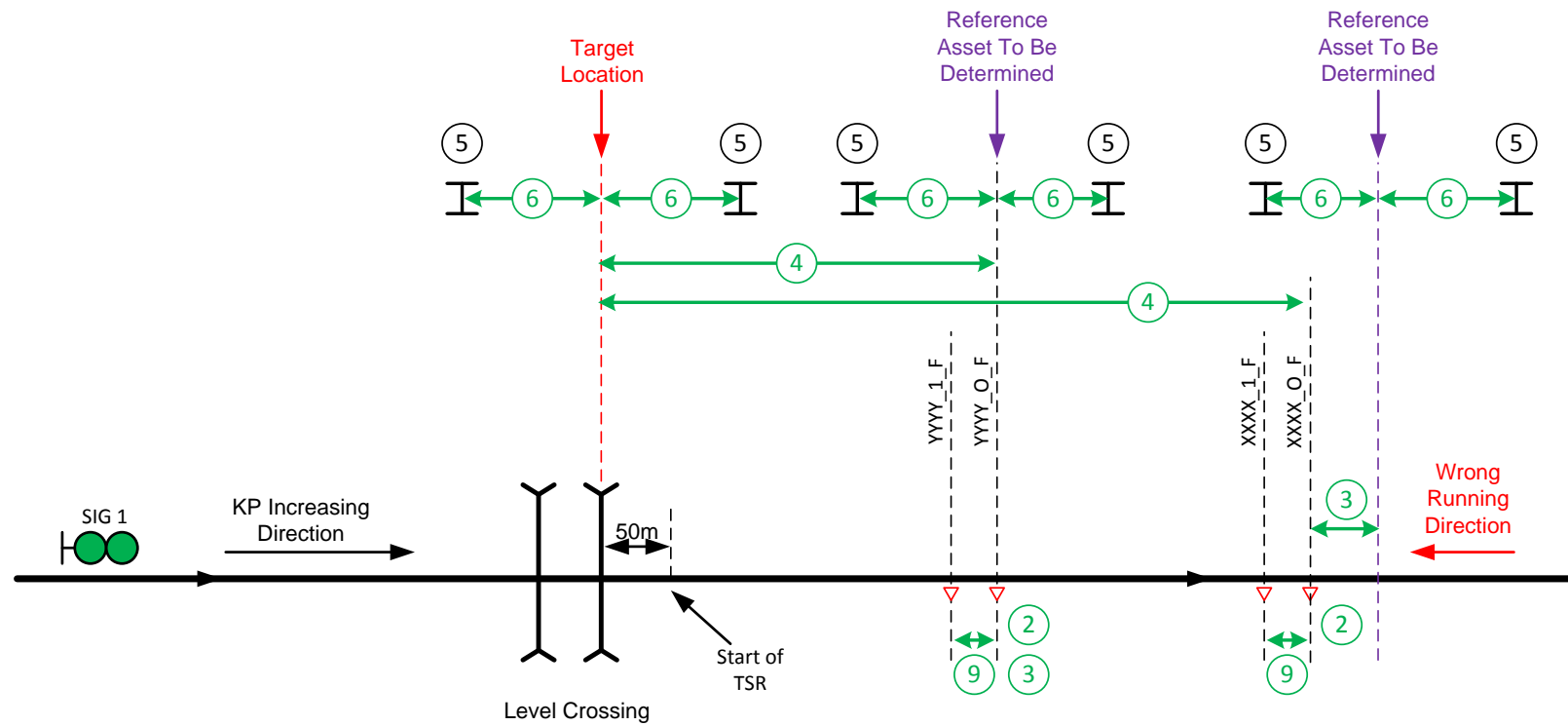

Legend  
△ Fixed Balise

Example showing Wrong Running Hazard protection at a Level Crossing.  
Note other ATP installations are excluded for simplicity.

Note: Only the applicable rows/columns in the SCF below are shown for this example.

| Balise Group ID | Target Location Name/ID [A] | Reference Asset Name/ID [B] | Distance from Reference Asset (m) |        | Distance (m) from LEU Interface Signal |        |                           |        | Verification of Target Location [A] |        |                        |  | Verification of Reference Asset [B] |  |                        |  |                         |  |        |     |
|-----------------|-----------------------------|-----------------------------|-----------------------------------|--------|--|--------|---------------------------|--------|-------------------------------------|--------|------------------------|--|-------------------------------------|--|------------------------|--|-------------------------|--|--------|-----|
|                 |                             |                             | to Balise N_PIG = 0               |        | to Balise N_PIG = 1                    |        | to replacement IRJ/TU [C] |        | to stop location at platform [D]    |        | Sydney Side OHWS Label | Distance (m) from Target Location to SS OHWS | Country Side OHWS Label             | Distance (m) from Target Location to CS OHWS | Sydney Side OHWS Label | Distance (m) from Reference Asset to SS OHWS | Country Side OHWS Label | Distance (m) from Reference Asset to CS OHWS |        |     |
|                 |                             |                             | Design                            | Actual | Design                                 | Actual | Design                    | Actual | Design                              | Actual |                        | Design                                       | Actual                              |  | Design                 | Actual                                       |                         | Design                                       | Actual |     |
| XXXX            | CS Level Crossing           | TBD                         | (3)                               |        | (3)+(9)                                |        |                           |        |                                     | (5)    | (6)                    |  | (5)                                 | (6)  |                        | (5)  | (6)                     |  | (5)    | (6) |
| YYYY            | same as BG XXXX             | TBD                         | (3)                               |        | (3)+(9)                                |        |                           |        |                                     |        |                        |  |                                     |  |                        | (5)  | (6)                     |  | (5)    | (6) |

Reference material only

Appendix B6 - Re-Positioning Balises

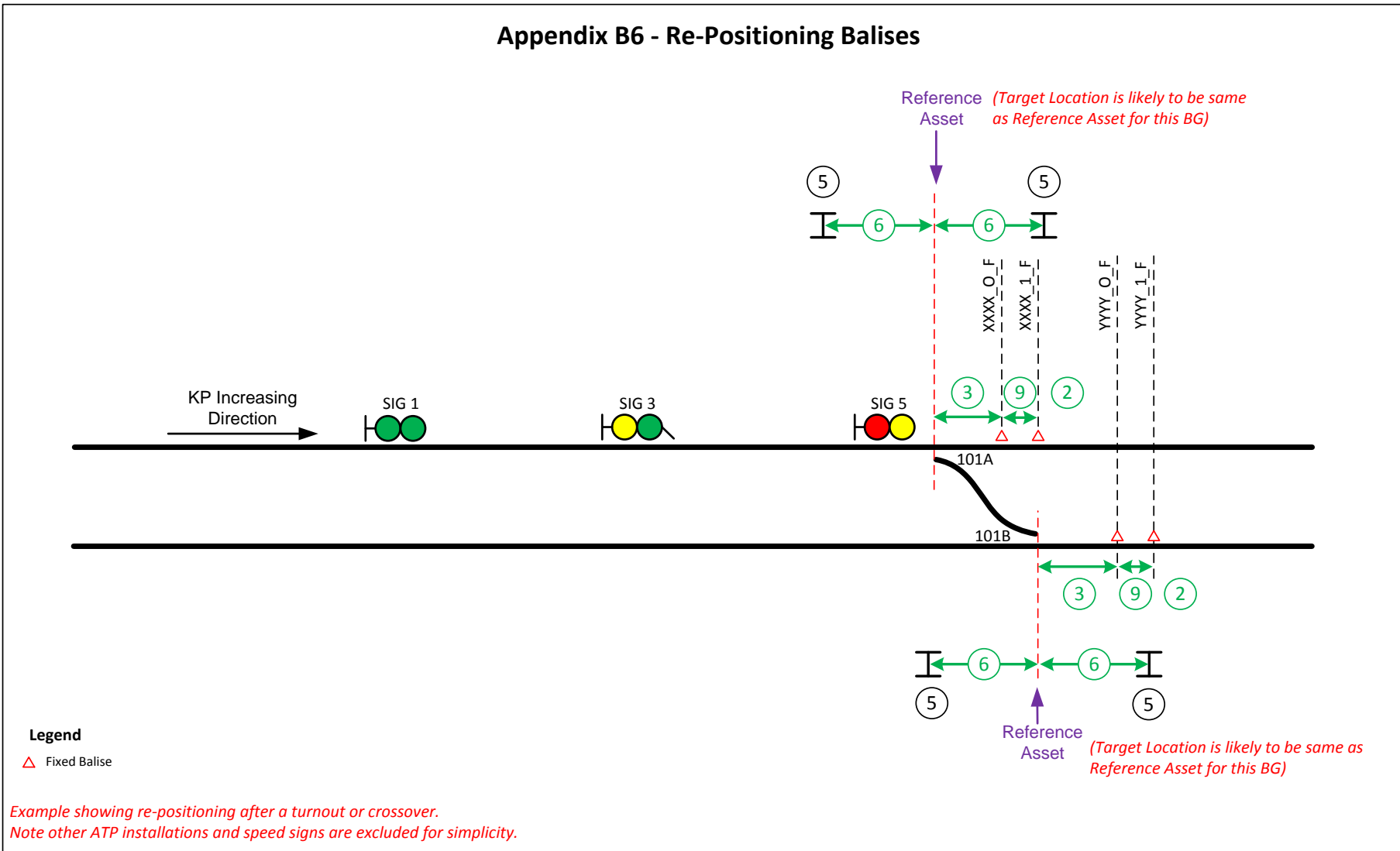

**Legend**  
△ Fixed Balise

Example showing re-positioning after a turnout or crossover.  
Note other ATP installations and speed signs are excluded for simplicity.

Note: Only the applicable rows/columns in the SCF below are shown for this example.

| Balise Group ID | Target Location Name/ID [A] | Reference Asset Name/ID [B] | Distance from Reference Asset (m) |        | Distance (m) from LEU Interface Signal |        | Verification of Target Location [A] |        |                                  |        | Verification of Reference Asset [B] |  |                         |  |                        |  |                         |  |        |  |
|-----------------|-----------------------------|-----------------------------|-----------------------------------|--------|--|--------|-------------------------------------|--------|----------------------------------|--------|-------------------------------------|--|-------------------------|--|------------------------|--|-------------------------|--|--------|--|
|                 |                             |                             | to Balise N_PIG = 0               |        | to Balise N_PIG = 1                    |        | to replacement IRJ/TU [C]           |        | to stop location at platform [D] |        | Sydney Side OHWS Label              | Distance (m) from Target Location to SS OHWS | Country Side OHWS Label | Distance (m) from Target Location to CS OHWS | Sydney Side OHWS Label | Distance (m) from Reference Asset to SS OHWS | Country Side OHWS Label | Distance (m) from Reference Asset to CS OHWS |        |  |
|                 |                             |                             | Design                            | Actual | Design                                 | Actual | Design                              | Actual | Design                           | Actual |                                     | Design                                       | Actual                  |  | Design                 | Actual                                       |                         | Design                                       | Actual |  |
| XXXX            | Same as Ref. Asset          | 101A                        | (3)                               |        | (3)+(9)                                |        |                                     |        |                                  |        |                                     |  |                         |  | (5)                    | (6)  |                         | (5)  | (6)    |  |
| YYYY            | Same as Ref. Asset          | 101B                        | (3)                               |        | (3)+(9)                                |        |                                     |        |                                  |        |                                     |  |                         |  | (5)                    | (6)  |                         | (5)  | (6)    |  |

Note that in this example the BG's are assumed to have been placed less than 100m from the toes of points. If BG's are being placed at a distance more than 100m from the toe of the point, then different reference assets will need to be selected and the toe of the point will need to be listed as a Target Location.



Reference material only

### Appendix B7 - Terminating Platforms 1

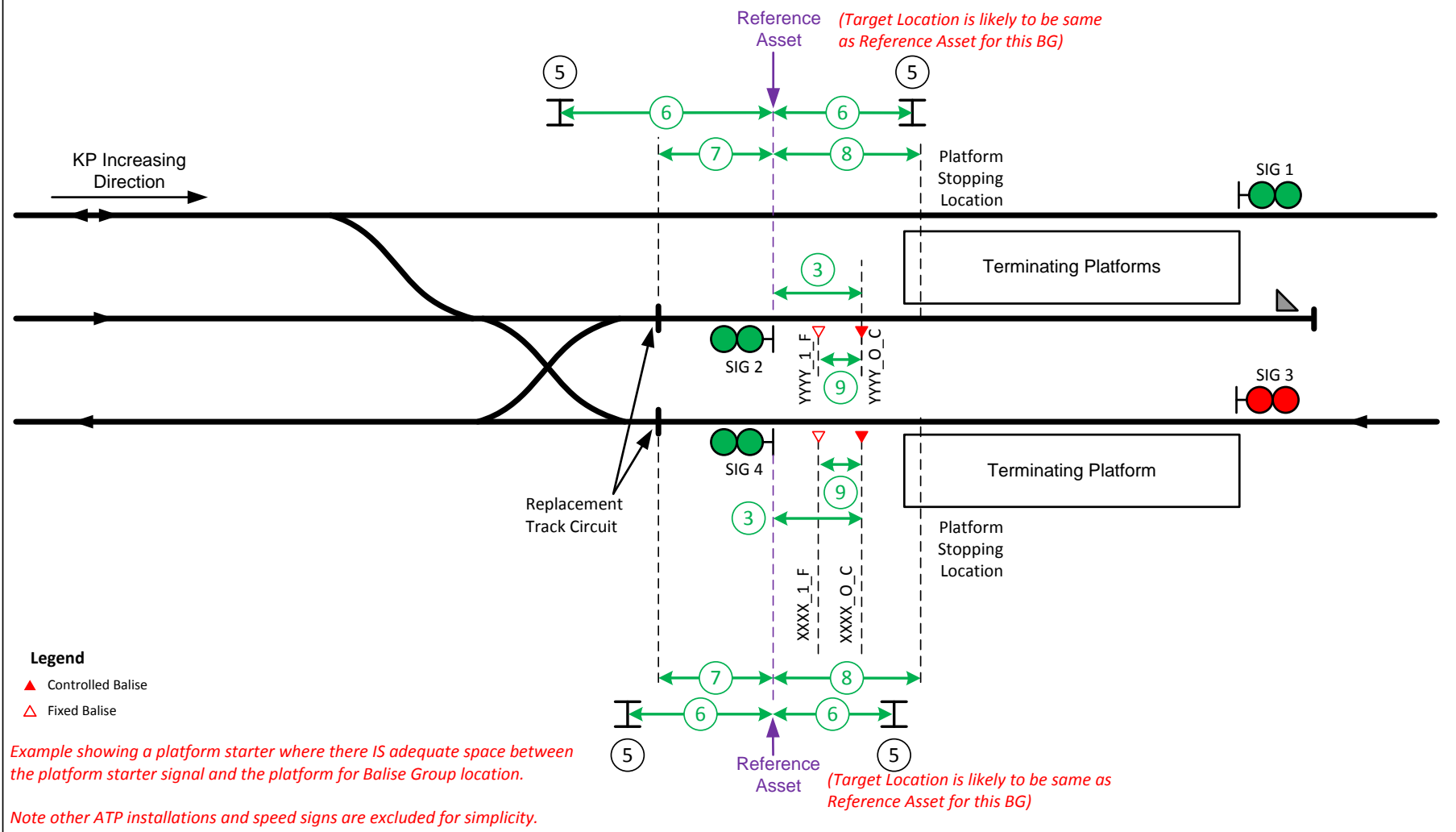

Note: Only the applicable rows/columns in the SCF below are shown for this example.

| Balise Group ID | Target Location Name/ID [A] | Reference Asset Name/ID [B] | Distance from Reference Asset (m) |        | Distance (m) from LEU Interface Signal |        |                           |        | Verification of Target Location [A] |        |                        |  | Verification of Reference Asset [B] |  |                        |  |                         |  |        |  |
|-----------------|-----------------------------|-----------------------------|-----------------------------------|--------|--|--------|---------------------------|--------|-------------------------------------|--------|------------------------|--|-------------------------------------|--|------------------------|--|-------------------------|--|--------|--|
|                 |                             |                             | to Balise N_PIG = 0               |        | to Balise N_PIG = 1                    |        | to replacement IRJ/TU [C] |        | to stop location at platform [D]    |        | Sydney Side OHWS Label | Distance (m) from Target Location to SS OHWS | Country Side OHWS Label             | Distance (m) from Target Location to CS OHWS | Sydney Side OHWS Label | Distance (m) from Reference Asset to SS OHWS | Country Side OHWS Label | Distance (m) from Reference Asset to CS OHWS |        |  |
|                 |                             |                             | Design                            | Actual | Design                                 | Actual | Design                    | Actual | Design                              | Actual |                        | Design                                       | Actual                              |  | Design                 | Actual                                       |                         | Design                                       | Actual |  |
| YYYY            | Same as Ref. Asset          | SIG 2                       | (3)                               |        | (3)+(9)                                |        | (7)                       |        | (8)                                 |        |                        |  |                                     |  | (5)                    | (6)  |                         | (5)  | (6)    |  |
| XXXX            | Same as Ref. Asset          | SIG 4                       | (3)                               |        | (3)+(9)                                |        | (7)                       |        | (8)                                 |        |                        |  |                                     |  | (5)                    | (6)  |                         | (5)  | (6)    |  |

Reference material only

### Appendix B8 - Terminating Platforms 2

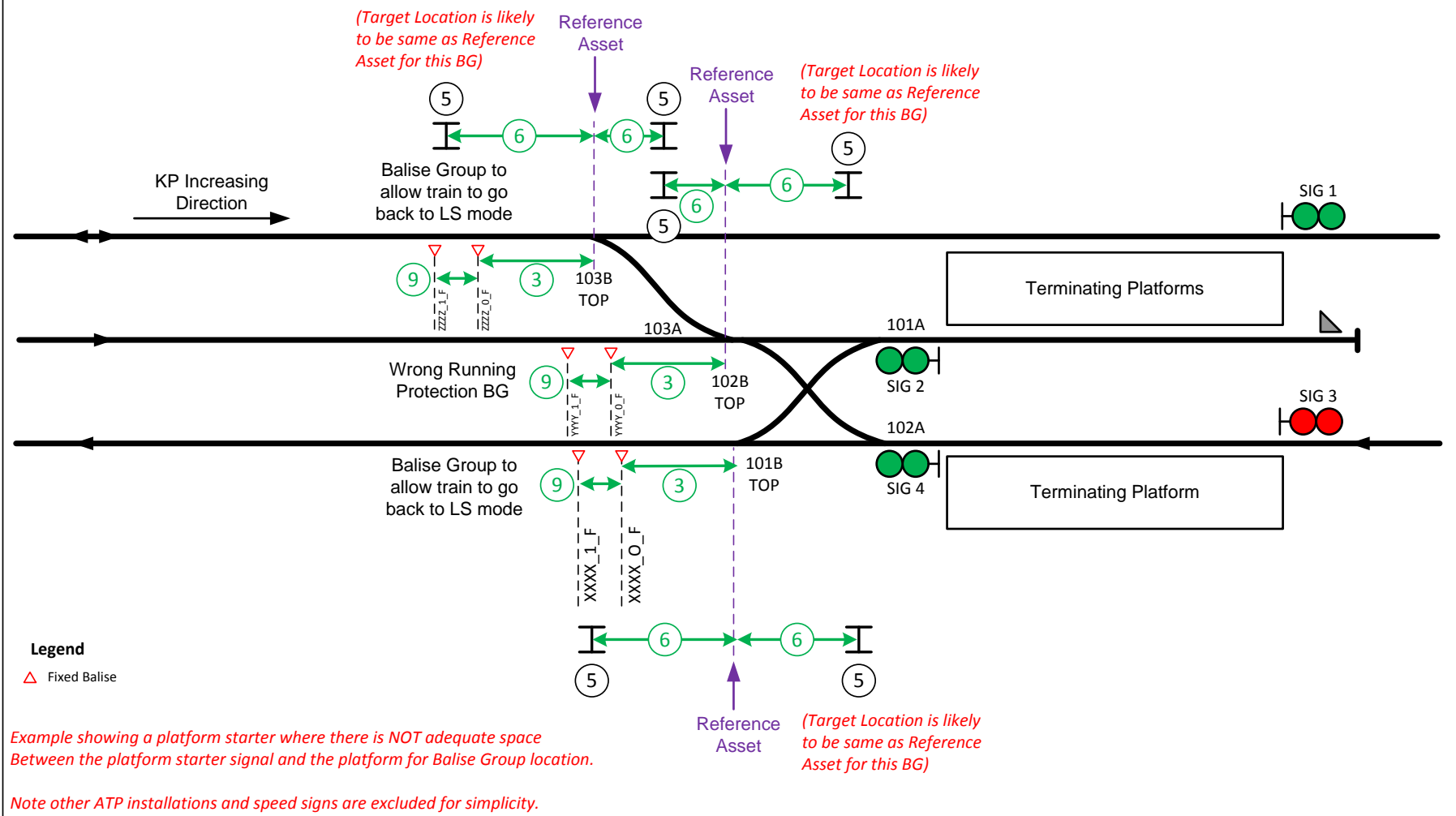

Note: Only the applicable rows/columns in the SCF below are shown for this example.

| Balise Group ID | Target Location Name/ID [A] | Reference Asset Name/ID [B] | Distance from Reference Asset (m) |        | Distance (m) from LEU Interface Signal |        |                           |        | Verification of Target Location [A] |        |                        |  | Verification of Reference Asset [B] |  |                        |  |                         |  |        |
|-----------------|-----------------------------|-----------------------------|-----------------------------------|--------|--|--------|---------------------------|--------|-------------------------------------|--------|------------------------|--|-------------------------------------|--|------------------------|--|-------------------------|--|--------|
|                 |                             |                             | to Balise N_PIG = 0               |        | to Balise N_PIG = 1                    |        | to replacement IRJ/TU [C] |        | to stop location at platform [D]    |        | Sydney Side OHWS Label | Distance (m) from Target Location to SS OHWS | Country Side OHWS Label             | Distance (m) from Target Location to CS OHWS | Sydney Side OHWS Label | Distance (m) from Reference Asset to SS OHWS | Country Side OHWS Label | Distance (m) from Reference Asset to CS OHWS |        |
|                 |                             |                             | Design                            | Actual | Design                                 | Actual | Design                    | Actual | Design                              | Actual |                        | Design                                       | Actual                              |  | Design                 | Actual                                       |                         | Design                                       | Actual |
| ZZZZ            | Same as Ref. Asset          | 103B                        | (3)                               |        | (3)+(9)                                |        |                           |        |                                     |        |                        |  |                                     |  | (5)                    | (6)  |                         | (5)  | (6)    |
| YYYY            | Same as Ref. Asset          | 103A                        | (3)                               |        | (3)+(9)                                |        |                           |        |                                     |        |                        |  |                                     |  | (5)                    | (6)  |                         | (5)  | (6)    |
| XXXX            | Same as Ref. Asset          | 101B                        | (3)                               |        | (3)+(9)                                |        |                           |        |                                     |        |                        |  |                                     |  | (5)                    | (6)  |                         | (5)  | (6)    |

Reference material only

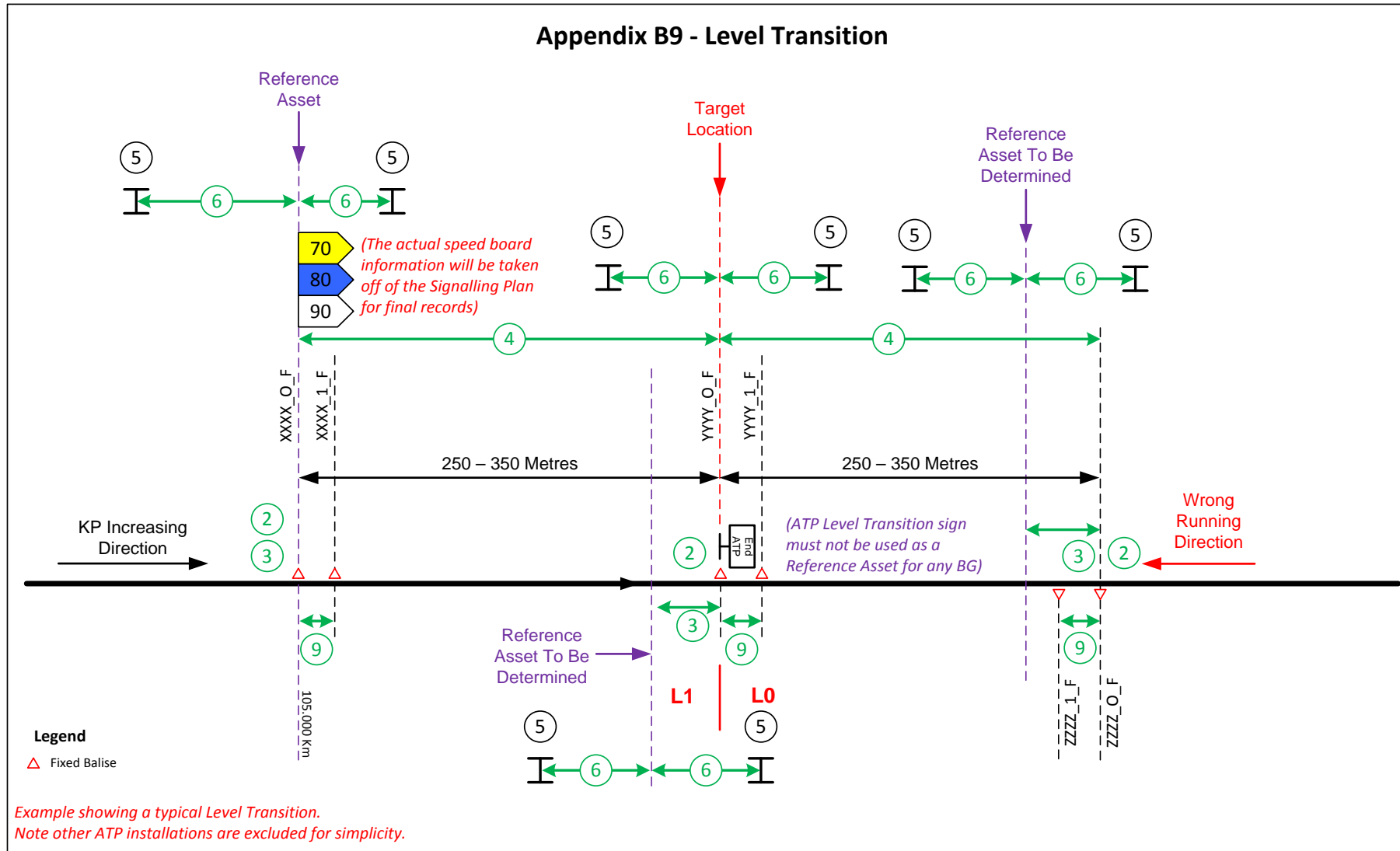

Note: Only the applicable rows/columns in the SCF below are shown for this example.

| Part A - Balise Installation/Test & Commissioning |                             |                             |                                   |        |                     |        |  |        |                                  |        |                                     |  |        | Part B - Geographical Data Verification      |  |        |                        |  |        |                         |  |        |
|---|-----------------------------|-----------------------------|-----------------------------------|--------|---------------------|--------|--|--------|----------------------------------|--------|-------------------------------------|--|--------|--|--|--------|------------------------|--|--------|-------------------------|--|--------|
| Measuring Tool:                                   |                             |                             |                                   |        |                     |        |  |        |                                  |        |                                     |  |        | Measuring Tool:                              |  |        |                        |  |        |                         |  |        |
| Accuracy of Tool (for measuring up to 100m):      |                             |                             |                                   |        |                     |        |  |        |                                  |        |                                     |  |        | Accuracy of Tool (for measuring up to 100m): |  |        |                        |  |        |                         |  |        |
| Calibration Date (if applicable):                 |                             |                             |                                   |        |                     |        |  |        |                                  |        |                                     |  |        | Calibration Date (if applicable):            |  |        |                        |  |        |                         |  |        |
| Measurement Date:                                 |                             |                             |                                   |        |                     |        |  |        |                                  |        |                                     |  |        | Measurement Date:                            |  |        |                        |  |        |                         |  |        |
| Balise Group ID                                   | Target Location Name/ID [A] | Reference Asset Name/ID [B] | Distance from Reference Asset (m) |        |                     |        | Distance (m) from LEU Interface Signal |        |                                  |        | Verification of Target Location [A] |  |        |  | Verification of Reference Asset [B]          |        |                        |  |        |                         |  |        |
|   |                             |                             | to Balise N_PIG = 0               |        | to Balise N_PIG = 1 |        | to replacement IRJ/TU [C]              |        | to stop location at platform [D] |        | Sydney Side OHWS Label              | Distance (m) from Target Location to SS OHWS |        | Country Side OHWS Label                      | Distance (m) from Target Location to CS OHWS |        | Sydney Side OHWS Label | Distance (m) from Reference Asset to SS OHWS |        | Country Side OHWS Label | Distance (m) from Reference Asset to CS OHWS |        |
|   |                             |                             | Design                            | Actual | Design              | Actual | Design                                 | Actual | Design                           | Actual |                                     | Design                                       | Actual |  | Design                                       | Actual |                        | Design                                       | Actual |                         | Design                                       | Actual |
| XXXX  | END ATP sign*               | 105.000km 70-80-90          | (3)                               |        | (3)+(9)             |        |  |        |                                  |        |                                     |  |        |  |  | (5)    | (6)                    |  | (5)    | (6)                     |  |        |
| YYYY  | END ATP sign*               | TBD                         | (3)                               |        | (3)+(9)             |        |  |        |                                  |        |                                     |  |        |  |  | (5)    | (6)                    |  | (5)    | (6)                     |  |        |
| ZZZZ  | END ATP sign*               | TBD                         | (3)                               |        | (3)+(9)             |        |  |        |                                  |        |                                     |  |        |  |  | (5)    | (6)                    |  | (5)    | (6)                     |  |        |

Reference material only

Appendix B10 - High Risk Deficient Overlap

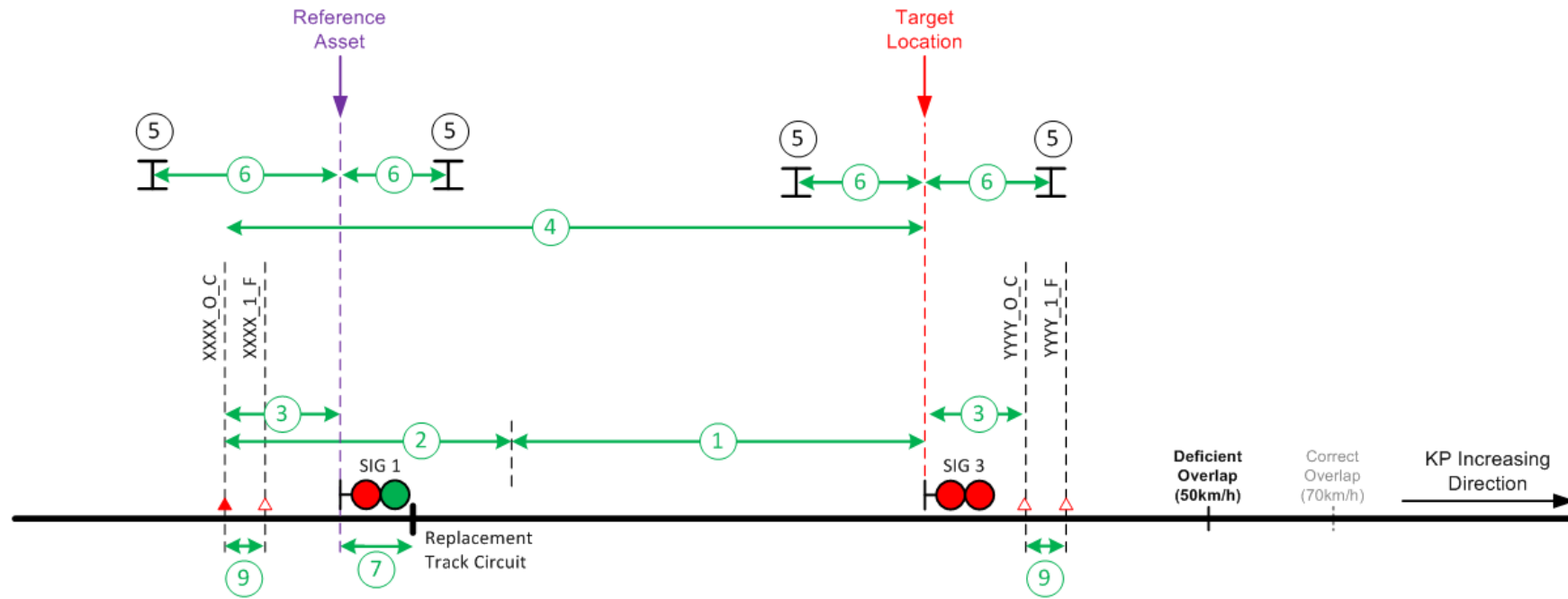

- Legend**
- ▲ Controlled Balise
  - △ Fixed Balise

Example showing a typical High Risk Deficient Overlap.  
Note other ATP installations and speed signs are excluded for simplicity.

Note: Only the applicable rows/columns in the SCF below are shown for this example.

| Part A - Balise Installation/Test & Commissioning |                             |                             |                                   |        |  |        |                           |        |                                     | Part B - Geographical Data Verification      |                        |  |        |                                     |  |        |                        |  |        |                         |  |        |
|---|-----------------------------|-----------------------------|-----------------------------------|--------|--|--------|---------------------------|--------|-------------------------------------|--|------------------------|--|--------|-------------------------------------|--|--------|------------------------|--|--------|-------------------------|--|--------|
| Measuring Tool:                                   |                             |                             |                                   |        | Measuring Tool:                        |        |                           |        |                                     | Accuracy of Tool (for measuring up to 100m): |                        |  |        |                                     | Accuracy of Tool (for measuring up to 100m): |        |                        |  |        |                         |  |        |
| Calibration Date (if applicable):                 |                             |                             |                                   |        | Calibration Date (if applicable):      |        |                           |        |                                     | Measurement Date:                            |                        |  |        |                                     | Measurement Date:                            |        |                        |  |        |                         |  |        |
| Balise Group ID                                   | Target Location Name/ID [A] | Reference Asset Name/ID [B] | Distance from Reference Asset (m) |        | Distance (m) from LEU Interface Signal |        |                           |        | Verification of Target Location [A] |  |                        |  |        | Verification of Reference Asset [B] |  |        |                        |  |        |                         |  |        |
|   |                             |                             | to Balise N_PIG = 0               |        | to Balise N_PIG = 1                    |        | to replacement IRJ/TU [C] |        | to stop location at platform [D]    |  | Sydney Side OHWS Label | Distance (m) from Target Location to SS OHWS |        | Country Side OHWS Label             | Distance (m) from Target Location to CS OHWS |        | Sydney Side OHWS Label | Distance (m) from Reference Asset to SS OHWS |        | Country Side OHWS Label | Distance (m) from Reference Asset to CS OHWS |        |
|   |                             |                             | Design                            | Actual | Design                                 | Actual | Design                    | Actual | Design                              | Actual                                       | Design                 | Actual                                       | Design | Actual                              | Design                                       | Actual | Design                 | Actual                                       | Design | Actual                  | Design                                       | Actual |
| XXXX  | SIG 3                       | SIG 1                       | (3)                               |        | (3)+(9)                                |        | (7)*                      |        |                                     | (5)  | (6)                    |  | (5)    | (6)                                 |  | (5)    | (6)                    |  | (5)    | (6)                     |  |        |
| YYYY  | Same as Ref. Asset          | SIG3                        | (3)                               |        | (3)+(9)                                |        |                           |        |                                     |  |                        |  |        |                                     |  | (5)    | (6)                    |  | (5)    | (6)                     |  |        |

Reference material only

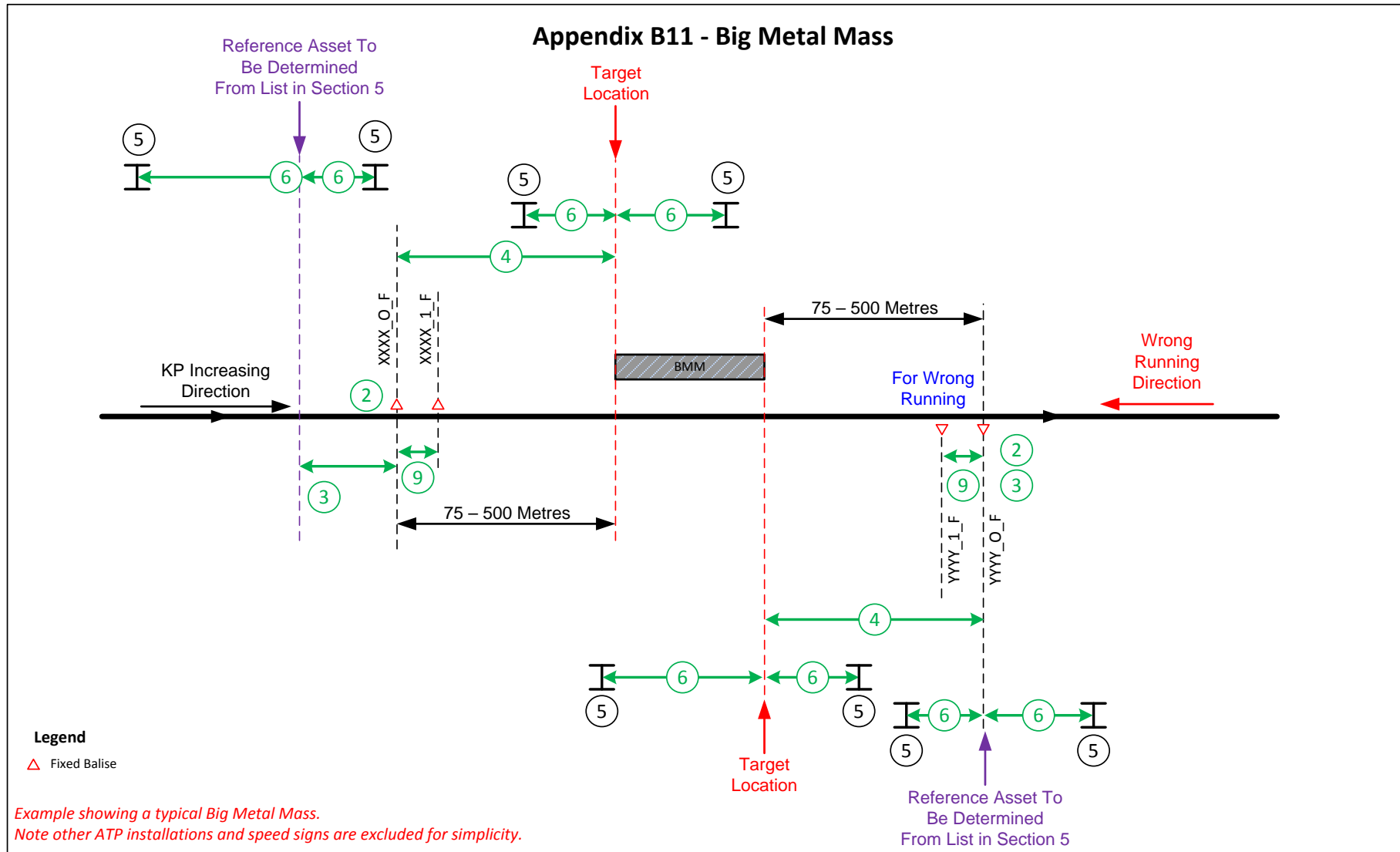

Note: Only the applicable rows/columns in the SCF below are shown for this example.

| Balise Group ID | Target Location Name/ID [A] | Reference Asset Name/ID [B] | Distance from Reference Asset (m) |        |                     |        | Distance (m) from LEU Interface Signal |        |                                  |        | Verification of Target Location [A] |  |                         |  | Verification of Reference Asset [B] |  |                         |  |        |     |
|-----------------|-----------------------------|-----------------------------|-----------------------------------|--------|---------------------|--------|--|--------|----------------------------------|--------|-------------------------------------|--|-------------------------|--|-------------------------------------|--|-------------------------|--|--------|-----|
|                 |                             |                             | to Balise N_PIG = 0               |        | to Balise N_PIG = 1 |        | to replacement IRJ/TU [C]              |        | to stop location at platform [D] |        | Sydney Side OHWS Label              | Distance (m) from Target Location to SS OHWS | Country Side OHWS Label | Distance (m) from Target Location to CS OHWS | Sydney Side OHWS Label              | Distance (m) from Reference Asset to SS OHWS | Country Side OHWS Label | Distance (m) from Reference Asset to CS OHWS |        |     |
|                 |                             |                             | Design                            | Actual | Design              | Actual | Design                                 | Actual | Design                           | Actual |                                     | Design                                       | Actual                  |  | Design                              | Actual                                       |                         | Design                                       | Actual |     |
| XXXX            | SS BMM                      | TBD                         | (3)                               |        | (3)+(9)             |        |  |        |                                  | (5)    | (6)                                 |  | (5)                     | (6)  |                                     | (5)  | (6)                     |  | (5)    | (6) |
| YYYY            | CS BMM                      | TBD                         | (3)                               |        | (3)+(9)             |        |  |        |                                  | (5)    | (6)                                 |  | (5)                     | (6)  |                                     | (5)  | (6)                     |  | (5)    | (6) |

Reference material only

Appendix B12 - Yard Entry / Exit

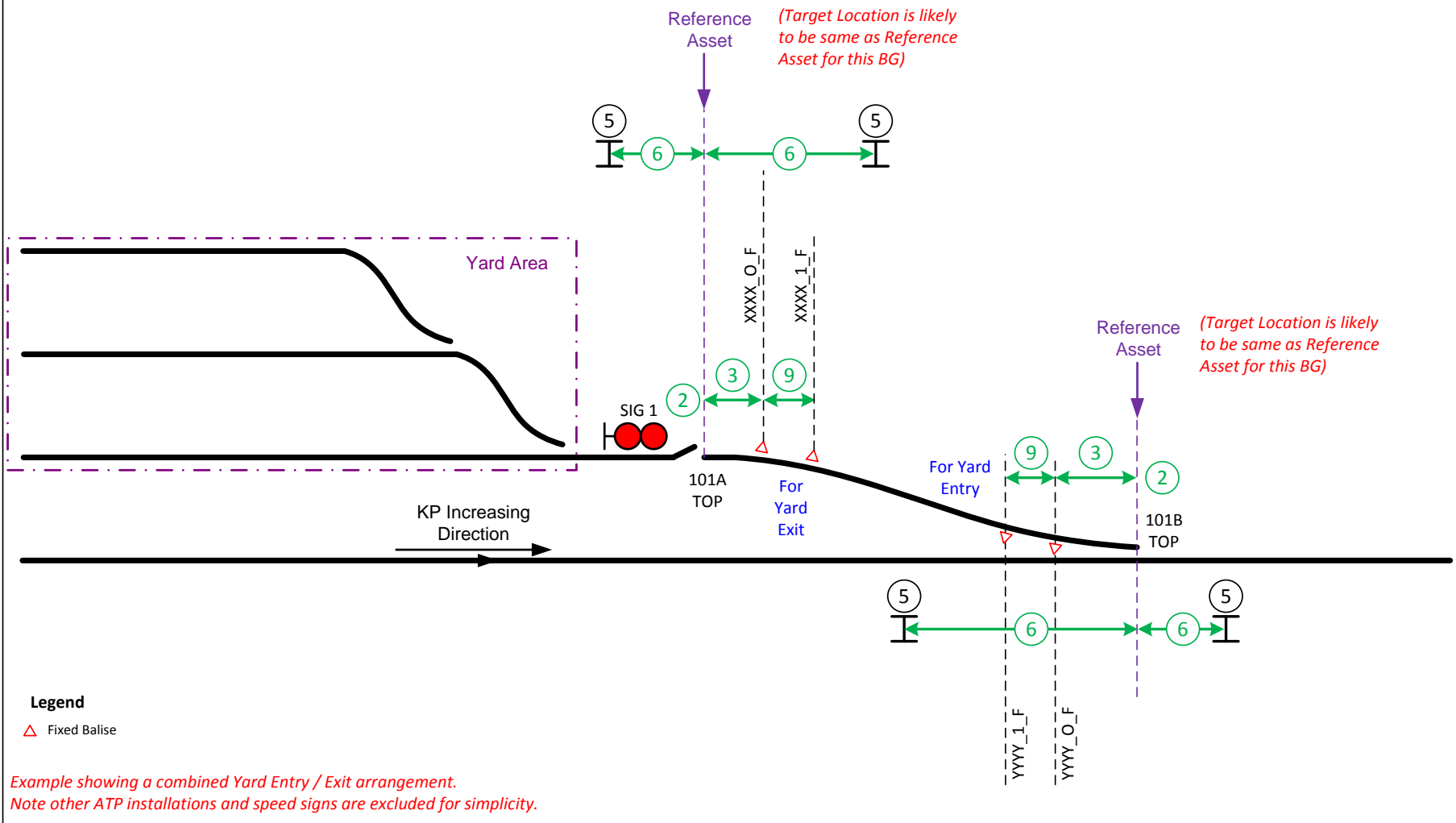

Note: Only the applicable rows/columns in the SCF below are shown for this example.

| Balise Group ID | Target Location Name/ID [A] | Reference Asset Name/ID [B] | Distance from Reference Asset (m) |        | Distance (m) from LEU Interface Signal |        |                           |        | Verification of Target Location [A] |        |                        |  | Verification of Reference Asset [B] |  |                        |  |                         |  |        |  |
|-----------------|-----------------------------|-----------------------------|-----------------------------------|--------|--|--------|---------------------------|--------|-------------------------------------|--------|------------------------|--|-------------------------------------|--|------------------------|--|-------------------------|--|--------|--|
|                 |                             |                             | to Balise N_PIG = 0               |        | to Balise N_PIG = 1                    |        | to replacement IRJ/TU [C] |        | to stop location at platform [D]    |        | Sydney Side OHWS Label | Distance (m) from Target Location to SS OHWS | Country Side OHWS Label             | Distance (m) from Target Location to CS OHWS | Sydney Side OHWS Label | Distance (m) from Reference Asset to SS OHWS | Country Side OHWS Label | Distance (m) from Reference Asset to CS OHWS |        |  |
|                 |                             |                             | Design                            | Actual | Design                                 | Actual | Design                    | Actual | Design                              | Actual |                        | Design                                       | Actual                              |  | Design                 | Actual                                       |                         | Design                                       | Actual |  |
| XXXX            | Same as Ref. Asset          | 101A                        | (3)                               |        | (3)+(9)                                |        |                           |        |                                     |        |                        |  |                                     |  | (5)                    | (6)  |                         | (5)  | (6)    |  |
| YYYY            | Same as Ref. Asset          | 101B                        | (3)                               |        | (3)+(9)                                |        |                           |        |                                     |        |                        |  |                                     |  | (5)                    | (6)  |                         | (5)  | (6)    |  |

Reference material only

Appendix B13 - Permanent Stop Signs / Fixed Red Signals

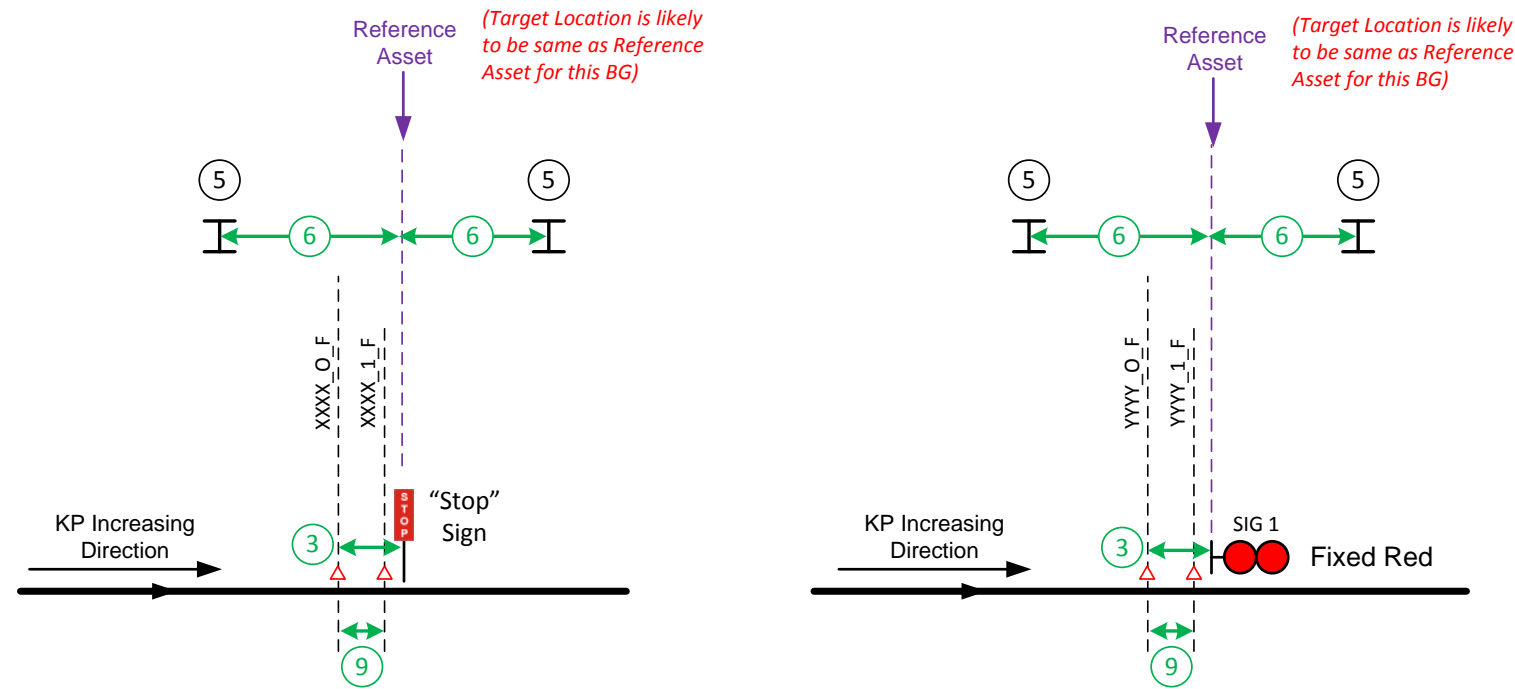

Legend  
△ Fixed Balise

Examples showing a "Stop Sign" and Fixed Red signal.  
Note other ATP installations and speed signs are excluded for simplicity.

Note: Only the applicable rows/columns in the SCF below are shown for this example.

| Balise Group ID | Target Location Name/ID [A] | Reference Asset Name/ID [B] | Distance from Reference Asset (m) |        | Distance (m) from LEU Interface Signal |        |                           |        | Verification of Target Location [A] |        |                        |  | Verification of Reference Asset [B] |  |                        |  |                         |  |        |  |
|-----------------|-----------------------------|-----------------------------|-----------------------------------|--------|--|--------|---------------------------|--------|-------------------------------------|--------|------------------------|--|-------------------------------------|--|------------------------|--|-------------------------|--|--------|--|
|                 |                             |                             | to Balise N_PIG = 0               |        | to Balise N_PIG = 1                    |        | to replacement IRJ/TU [C] |        | to stop location at platform [D]    |        | Sydney Side OHWS Label | Distance (m) from Target Location to SS OHWS | Country Side OHWS Label             | Distance (m) from Target Location to CS OHWS | Sydney Side OHWS Label | Distance (m) from Reference Asset to SS OHWS | Country Side OHWS Label | Distance (m) from Reference Asset to CS OHWS |        |  |
|                 |                             |                             | Design                            | Actual | Design                                 | Actual | Design                    | Actual | Design                              | Actual |                        | Design                                       | Actual                              |  | Design                 | Actual                                       |                         | Design                                       | Actual |  |
| XXXX            | Same as Ref. Asset          | STOP SIGN                   | (3)                               |        | (3)+(9)                                |        |                           |        |                                     |        |                        |  |                                     |  | (5)                    | (6)  |                         | (5)  | (6)    |  |
| YYYY            | Same as Ref. Asset          | SIG 1                       | (3)                               |        | (3)+(9)                                |        |                           |        |                                     |        |                        |  |                                     |  | (5)                    | (6)  |                         | (5)  | (6)    |  |

Reference material only

Appendix B14 - High Risk Turnout

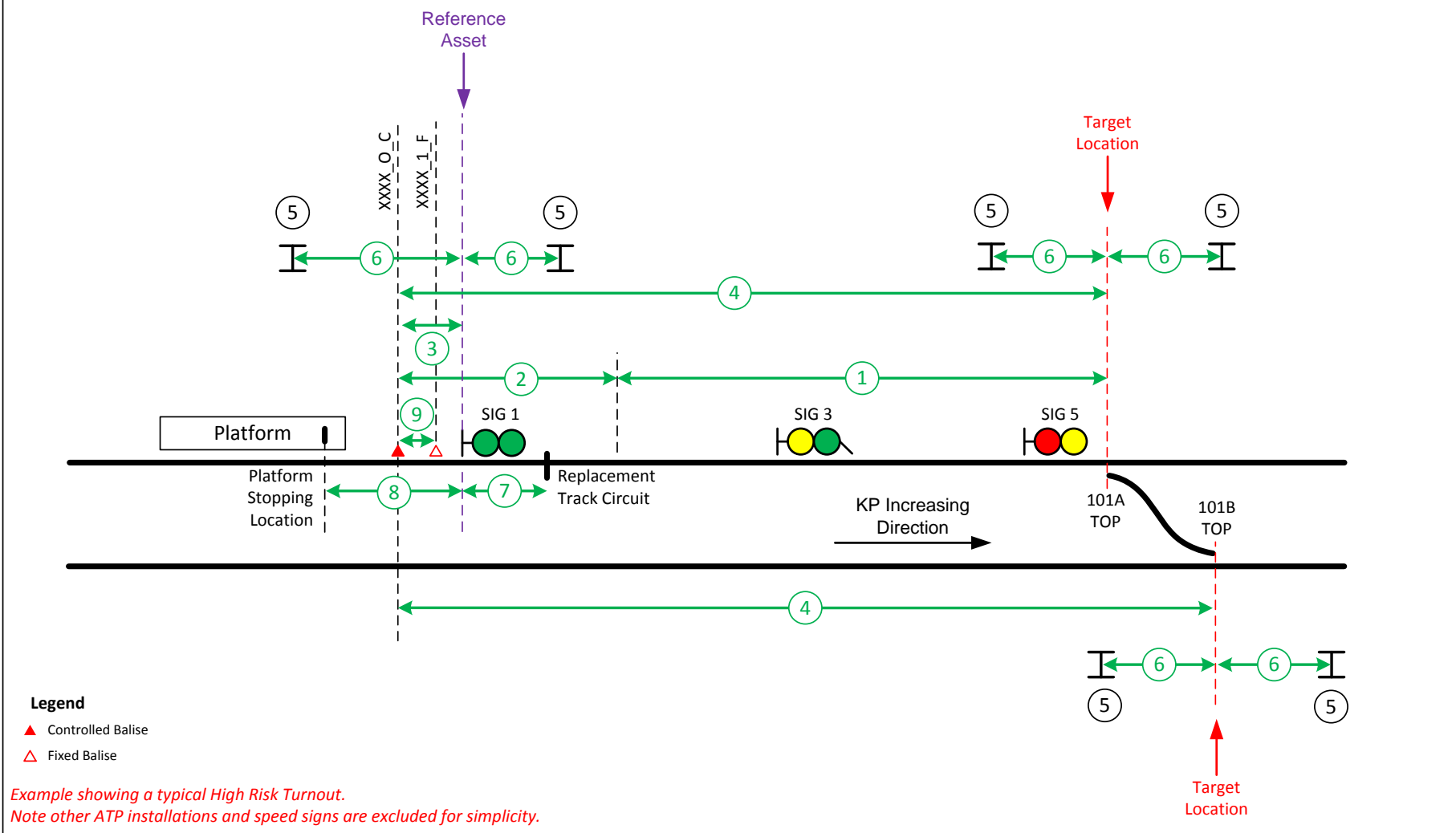

- Legend**
- ▲ Controlled Balise
  - △ Fixed Balise

Example showing a typical High Risk Turnout.  
Note other ATP installations and speed signs are excluded for simplicity.

Note: Only the applicable rows/columns in the SCF below are shown for this example.

**Site Specific Notes:**  
\* contact detail design if on site distance is less than the design value.  
\*\* 101B is also a Target Location for BG XXXX and location of 101B must be site certified

| Part A - Balise Installation/Test & Commissioning |                             |                             |                                   |        |                     |        |  |        |                                  | Part B - Geographical Data Verification      |                                     |  |        |                         |  |                                     |                        |  |        |                         |  |        |
|---|-----------------------------|-----------------------------|-----------------------------------|--------|---------------------|--------|--|--------|----------------------------------|--|-------------------------------------|--|--------|-------------------------|--|-------------------------------------|------------------------|--|--------|-------------------------|--|--------|
| Measuring Tool:                                   |                             |                             |                                   |        |                     |        |  |        |                                  | Measuring Tool:                              |                                     |  |        |                         |  |                                     |                        |  |        |                         |  |        |
| Accuracy of Tool (for measuring up to 100m):      |                             |                             |                                   |        |                     |        |  |        |                                  | Accuracy of Tool (for measuring up to 100m): |                                     |  |        |                         |  |                                     |                        |  |        |                         |  |        |
| Calibration Date (if applicable):                 |                             |                             |                                   |        |                     |        |  |        |                                  | Calibration Date (if applicable):            |                                     |  |        |                         |  |                                     |                        |  |        |                         |  |        |
| Measurement Date:                                 |                             |                             |                                   |        |                     |        |  |        |                                  | Measurement Date:                            |                                     |  |        |                         |  |                                     |                        |  |        |                         |  |        |
| Balise Group ID                                   | Target Location Name/ID [A] | Reference Asset Name/ID [B] | Distance from Reference Asset (m) |        |                     |        | Distance (m) from LEU Interface Signal |        |                                  |  | Verification of Target Location [A] |  |        |                         |  | Verification of Reference Asset [B] |                        |  |        |                         |  |        |
|   |                             |                             | to Balise N_PIG = 0               |        | to Balise N_PIG = 1 |        | to replacement IRJ/TU [C]              |        | to stop location at platform [D] |  | Sydney Side OHWS Label              | Distance (m) from Target Location to SS OHWS |        | Country Side OHWS Label | Distance (m) from Target Location to CS OHWS |                                     | Sydney Side OHWS Label | Distance (m) from Reference Asset to SS OHWS |        | Country Side OHWS Label | Distance (m) from Reference Asset to CS OHWS |        |
|   |                             |                             | Design                            | Actual | Design              | Actual | Design                                 | Actual | Design                           | Actual                                       |                                     | Design                                       | Actual |                         | Design                                       | Actual                              |                        | Design                                       | Actual |                         | Design                                       | Actual |
| XXXX  | 101A                        | SIG 1                       | (3)                               |        | (3)+(9)             |        | (7)*                                   |        | (8)                              |  | (5)                                 | (6)  |        | (5)                     | (6)  |                                     | (5)                    | (6)  |        | (5)                     | (6)  |        |
|   | 101B**                      |                             |                                   |        |                     |        |  |        |                                  | (5)  | (6)                                 |  | (5)    | (6)                     |  |                                     |                        |  |        |                         |  |        |



## Appendix C. RFI for GIS Extract

### C1. RFI Structure

The specifics of the RFI will depend on the requirements identified at the time of request. The following must be included as a minimum:

- Document control information containing unique ID for RFI, details of RFI author/owner and request date
- Overview of the request including;
  1. Tracks for which location data is required, e.g. Up Main North
  2. Extends of geographic area, e.g. Gosford to Wyong
- Clearly identify the deliverables, as a minimum the following must be provided:
  1. Standard GIS Extract, this refers to an agreed set of POIs and specific set of attributes per POI as detailed in appendix C2,
  2. Any non-standard request, these can be as follows;
    - Additional POI,
    - Additional Attribute for an existing POI,
    - Additional supporting material, e.g. Map book of the area to provide a visual interface to the data. This is not required if the designer has access to WebGIS

Note that GIS may not be able to meet these non-standard requests.

- Provide a schedule by which the input data is required
- Work order number or other appropriate means for covering Sydney Trains cost of data extraction
- Contact details of interface manager and/or point of contact for this RFI

### C2: Content of Standard GIS Extract

- File Format: Microsoft Excel file
- Included POIs:
  - Signals
  - Mechanical Trainstops
  - Permanent Stop Signs
  - Speed Signs
  - Buffer Stops
  - Km Posts

Reference material only

- OHWS
- Half Km Posts
- Toe of Points
- Edge of Level/Pedestrian Crossings (data can be incomplete for this POI)
- Platform Edge (data can be incomplete for this POI)
- Car Markers (data can be incomplete for this POI)
- Minimum attributes provided for each POI:
  - Unique GIS ID
  - Name/label of the POI
  - Track Base Code
  - Track Name
  - Kilometrage Reference (as per Survey Alignment database)
  - Rolling distance (distance from the start of track base code)
- Report any known discrepancies in data to ATP such that other measures can be arranged, e.g. POI requested by TfNSW is not available etc.

Reference material only

## Appendix D. Handling of inconsistency in WebGIS

The presentation layer in WebGIS for displaying various assets may not always present the icons at the correct locations. There may exist an offset for the viewing convenience.

There may also be cases where presented assets are not at the correct locations due to inaccurate inputs provided from the site.

Therefore, it is recommended to cross-check the location of the presented icon to the location given by the kilometrage reference and also to the aerial and the front of the train images provided in WebGIS and WebGIS NV.

Checking of all possible sources within WebGIS when measuring the rolling distance of any reference point (Speed signs, turnout, catch point, signal, etc.) can improve the efficiency in correlating the design values to the site surveyed values.

Two working examples are provided below to highlight the importance.

### D.1 Speed Sign [75, 75, 75] @ 81.825Km – ATP Area 2

Consider measuring the rolling distance for a speed sign in 20. The designer needs to measure two rolling distances on each side as indicated by the orange arrows.

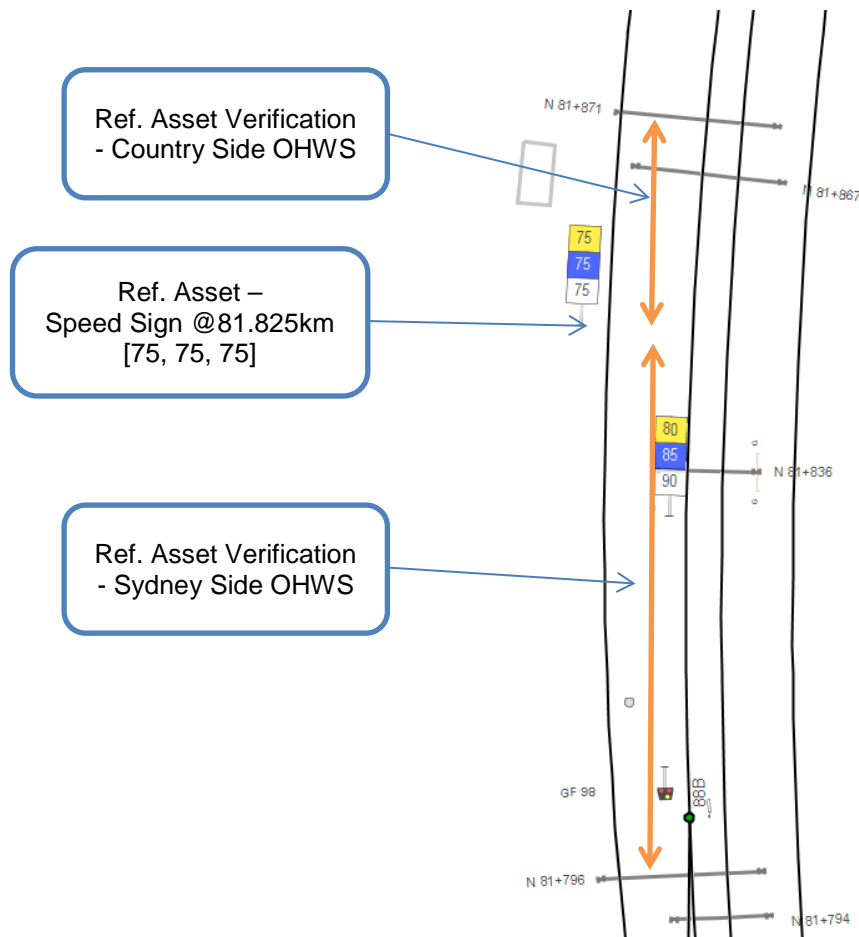

Figure 20 – Rolling distance measurement for a speed sign at 81.825km [75, 75, 75] ATP Area 2

Reference material only

Table 1 – Completed SCF extract for the speed sign at 81.825km

| Ref. Asset                 | Sydney-Side OHWS |       | Sydney-Side OHWS |       | Country-Side OHWS |      | Country-Side OHWS |      |
|----------------------------|------------------|-------|------------------|-------|-------------------|------|-------------------|------|
|                            | 1                |       | 2                |       | 1                 |      | 2                 |      |
|                            | Design Values    |       | Actual Values    |       | Design Values     |      | Actual Values     |      |
| SS[75-75-75]<br>(81.825KM) | N81+796          | -55.1 | N81+796          | -36.2 | N81+871           | 21.2 | N81+871           | 40.2 |

The completed SCF for the speed sign is shown in Table 1. And there is a clear difference between the WebGIS measured values to the actual surveyed values.

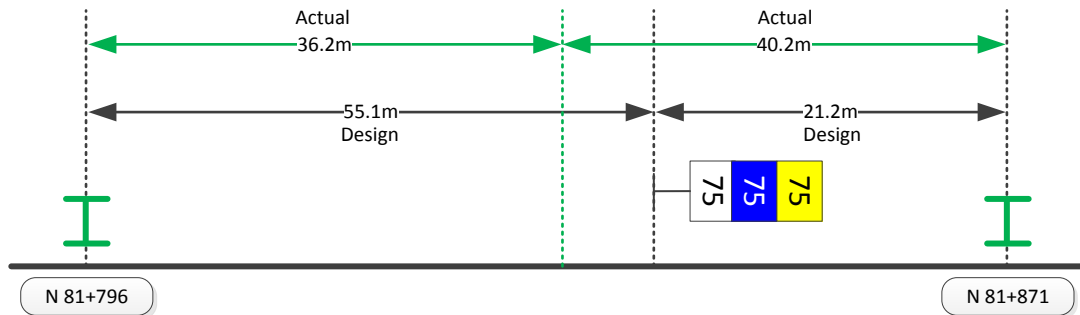

As the differences are more than +/- 2m, this particular scenario requires additional time and resources to validate the measurements.

This situation could have been avoided by taking a closer look at other sources within WebGIS.

Reference material only

1\_12\_v01\_201701021225\_00167.jpg(168)

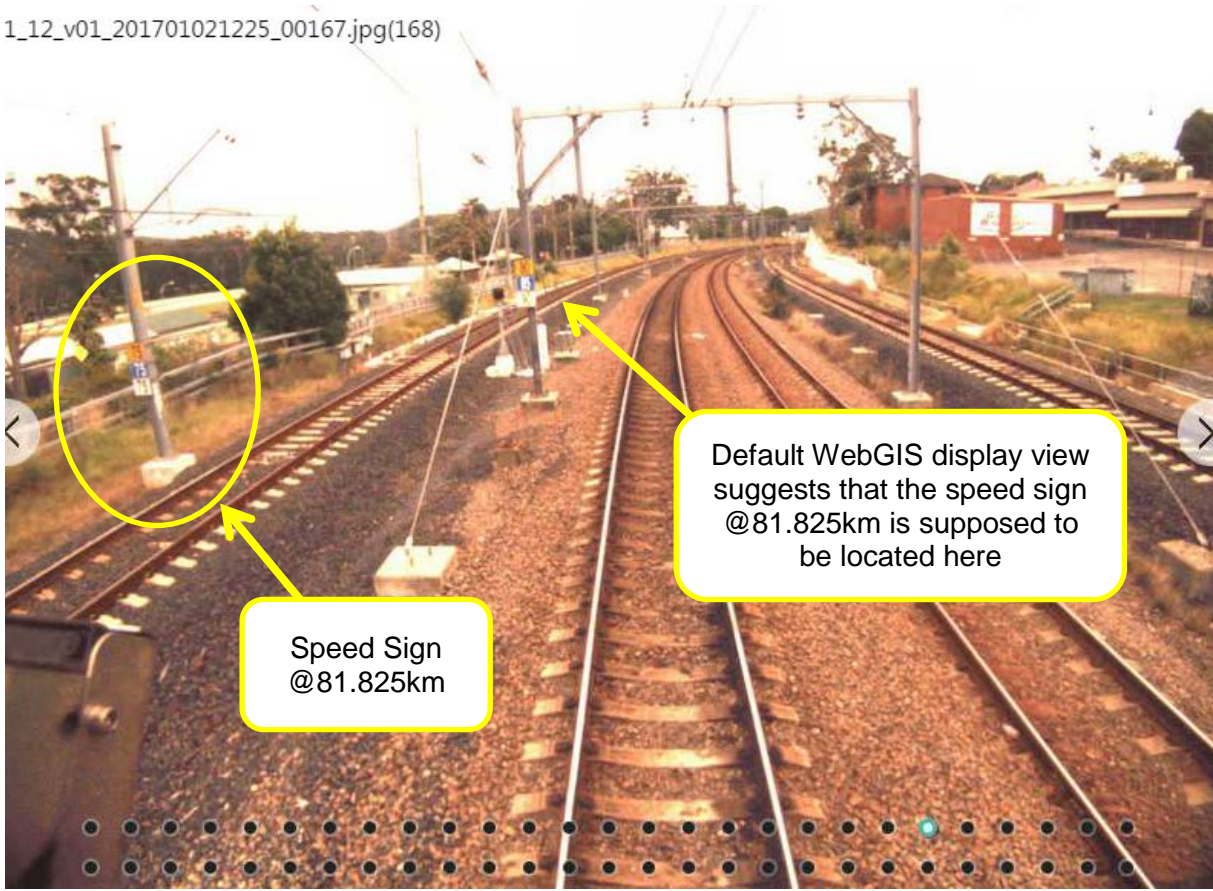

Figure 21 - Front of Train image of the speed sign at 81.825km

As shown in Figure 21, the front of train image shows that the speed sign is at a different location further down the track before the speed sign [80, 85, 90]. It is also possible to deduce that the speed sign is mounted on an OHWS.

Corresponding aerial photo image of the speed sign also confirms that the WebGIS display of the speed sign is offset from the actual location.

Reference material only

Reference material only

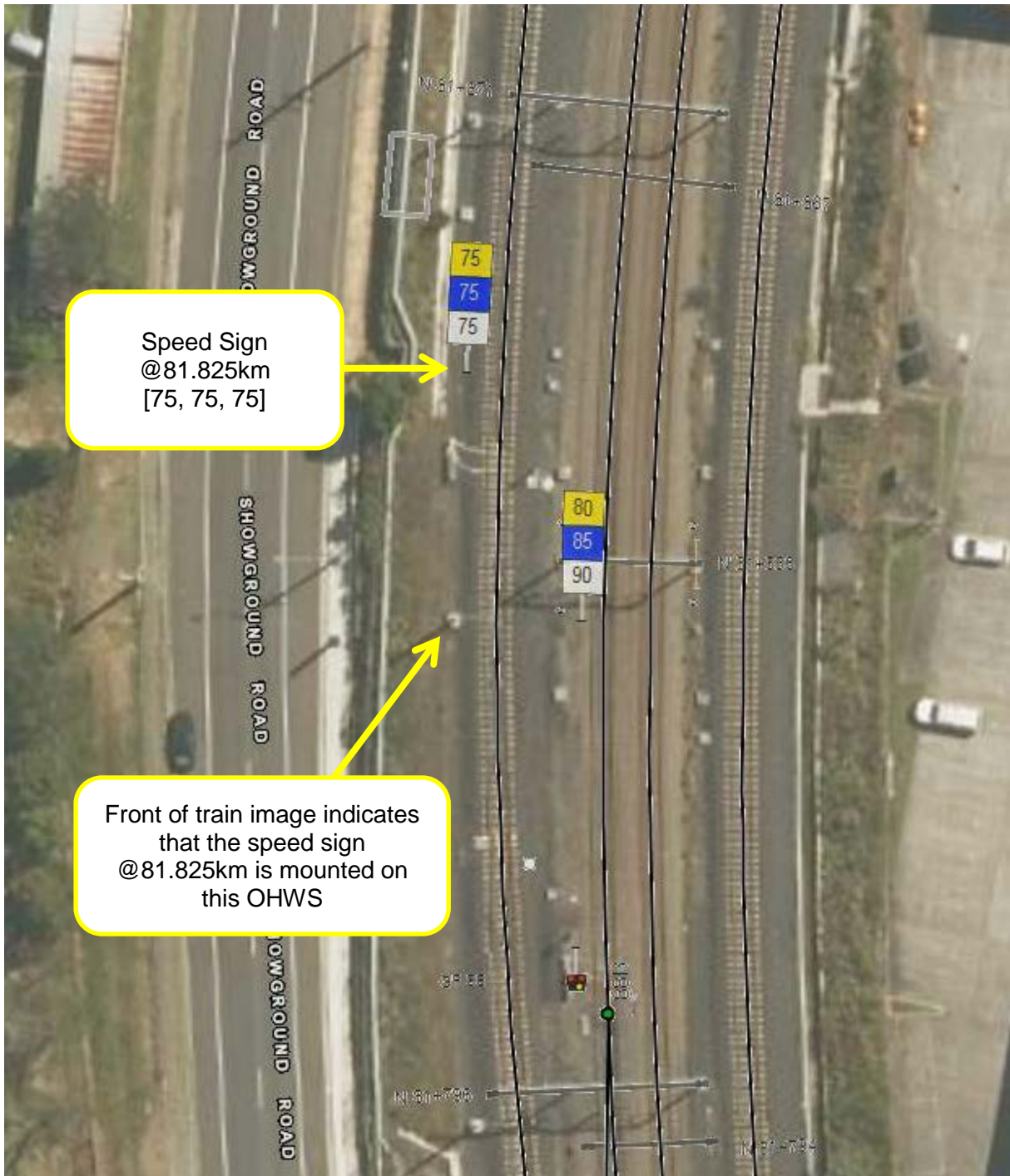

Figure 22 – Aerial photo image of the speed sign at 81.825km

Measuring the rolling distances from the updated location gives the following results shown in Figure 23 and Figure 24.

Reference material only

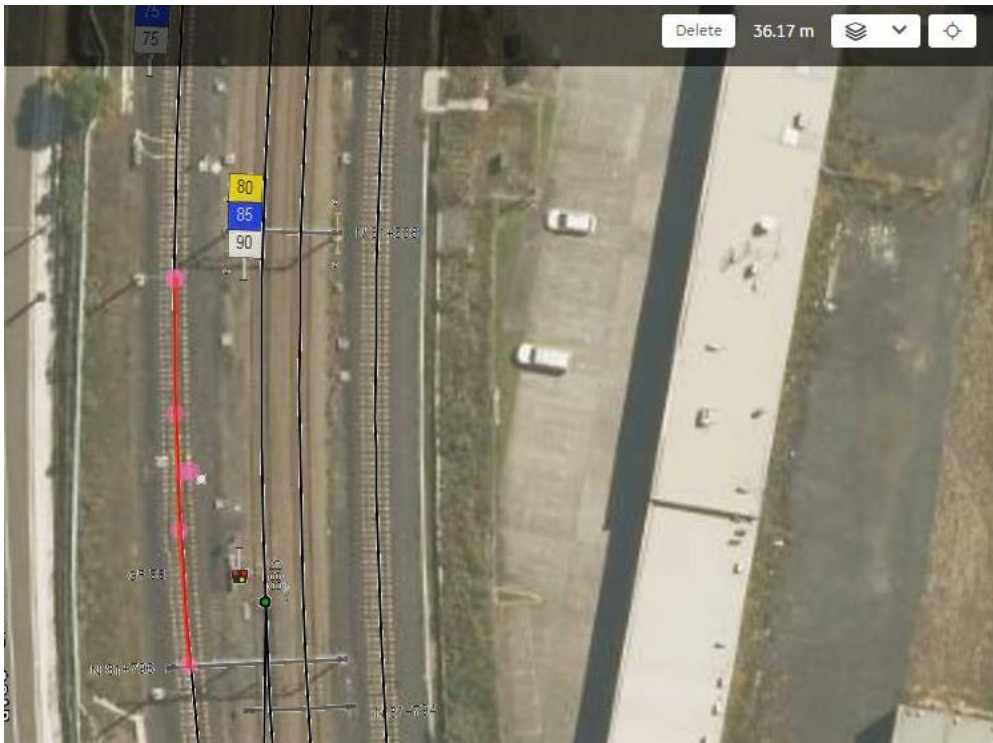

Figure 23 – Sydney side measurement based on the new speed sign location

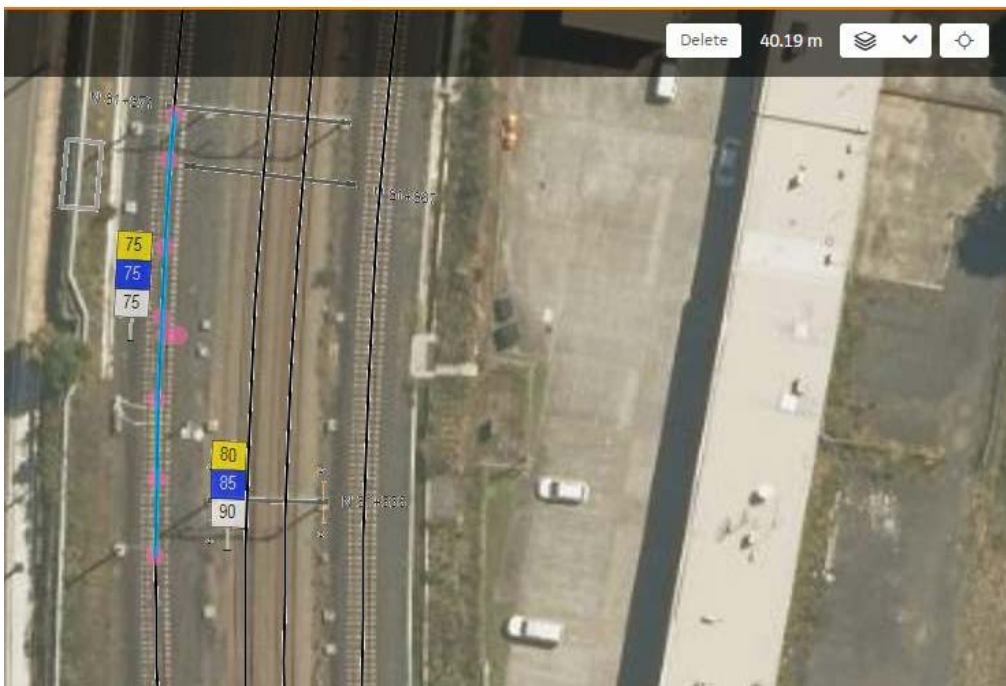

Figure 24 – Country side measurement based on the new speed sign location

The design values based on the new location are now aligned with the site survey values.

Also, any changes in the design value due to the offsets between the displayed icons to the photo imageries shall be captured in the supporting documentation to accompany the signal design submission.

For those cases where it is difficult to determine the correct location of a reference due to ambiguous or unclear imageries then the discretion shall be exercised to draw out the best possible values for verification.

### D.2 Catch point 21A at Gosford

Similarly, it is often the case that WebGIS displays the toe of a catch point instead of the throw rail which is the reference point for rolling distance measurement. The signal designer shall ensure that the measurement is made to the throw rail by checking all possible sources.

For example, 21A catch point located in Gosford displays as show in,

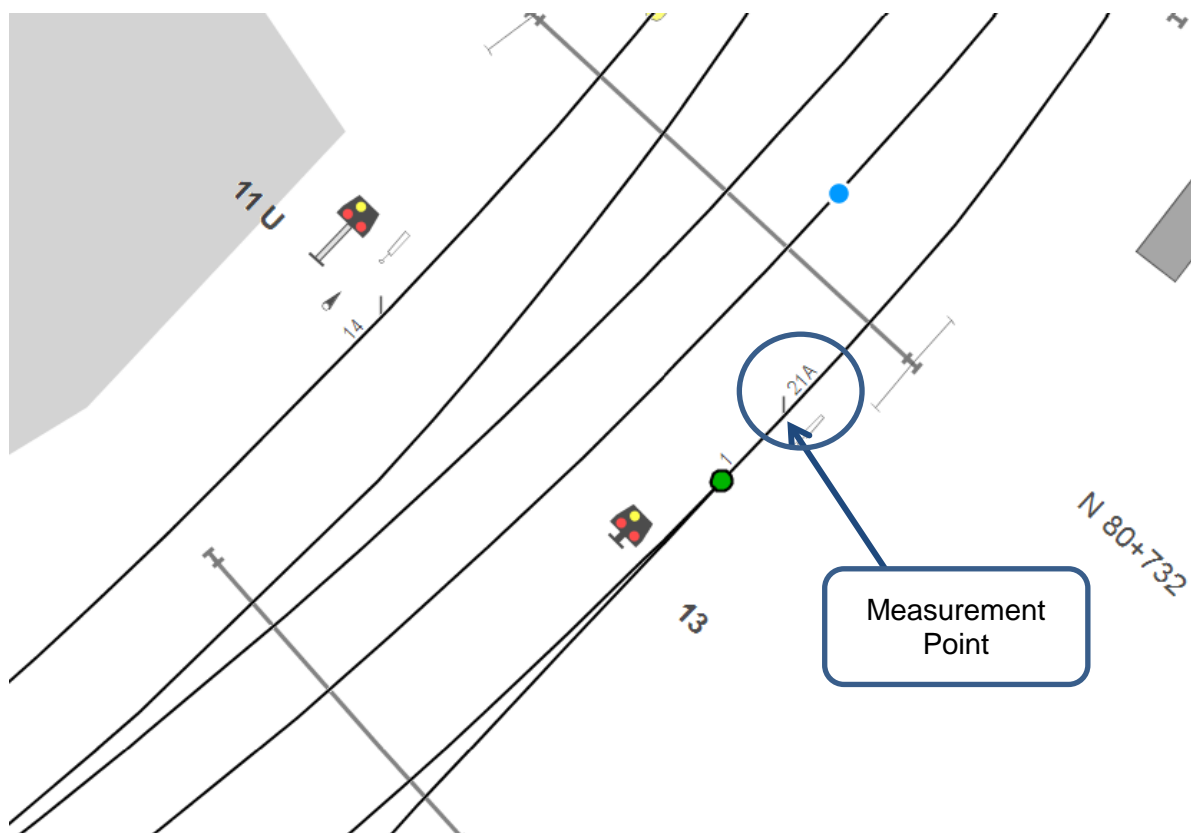

**Figure 25 – 21A Catch point at Gosford**

However, the throw rail is actually located beyond OHWS N 80+732 as indicated by the front of train image in Figure 26.

Reference material only



Reference material only

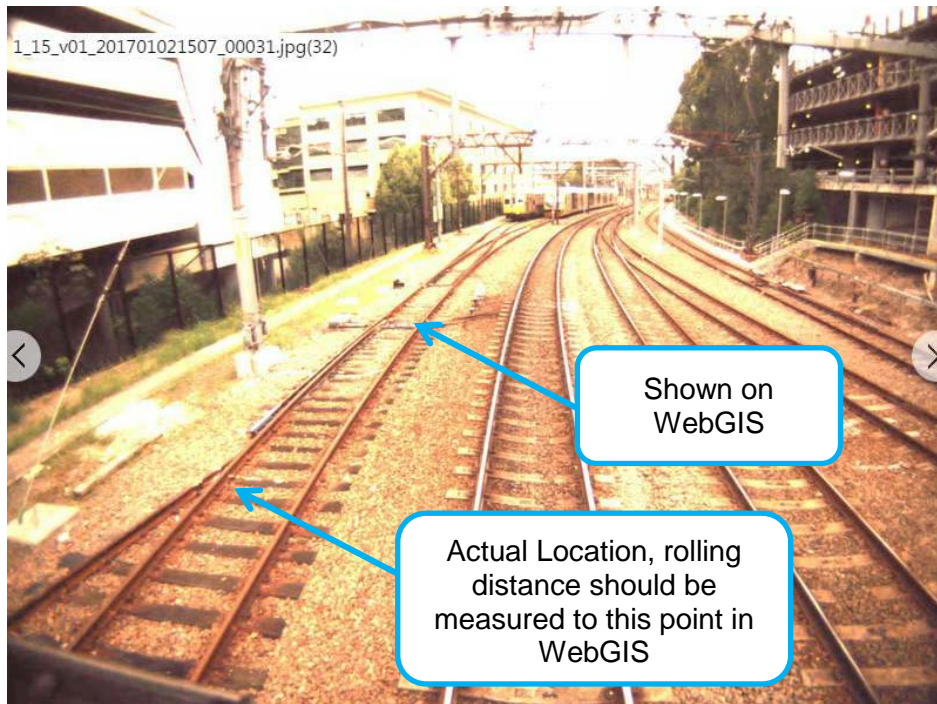

Figure 26 – Front of train image showing different throw rail location